

UNITEC™
SERIES

UX Series

Engineering Operation & Maintenance

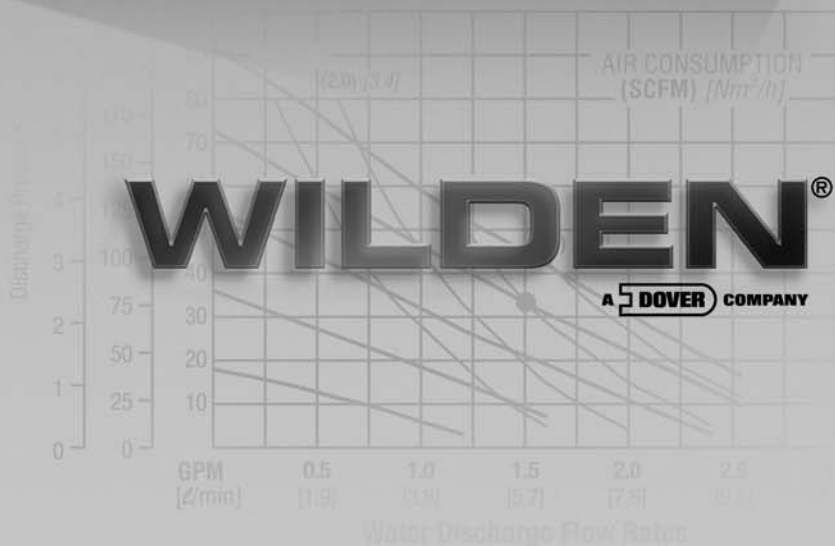
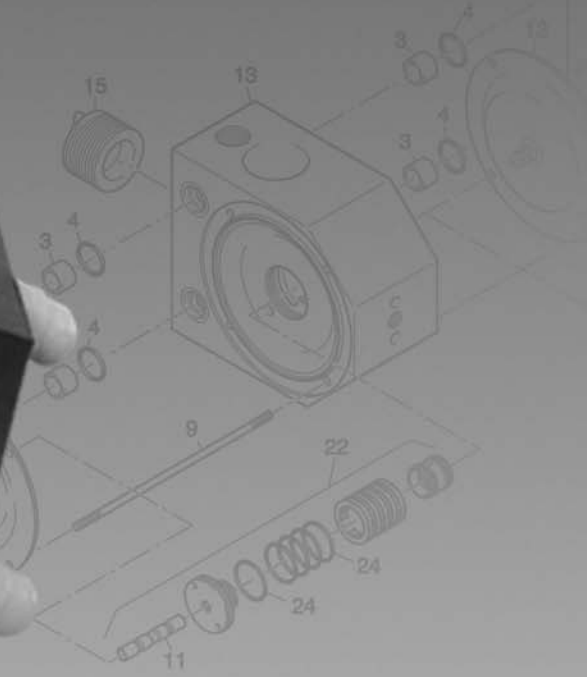
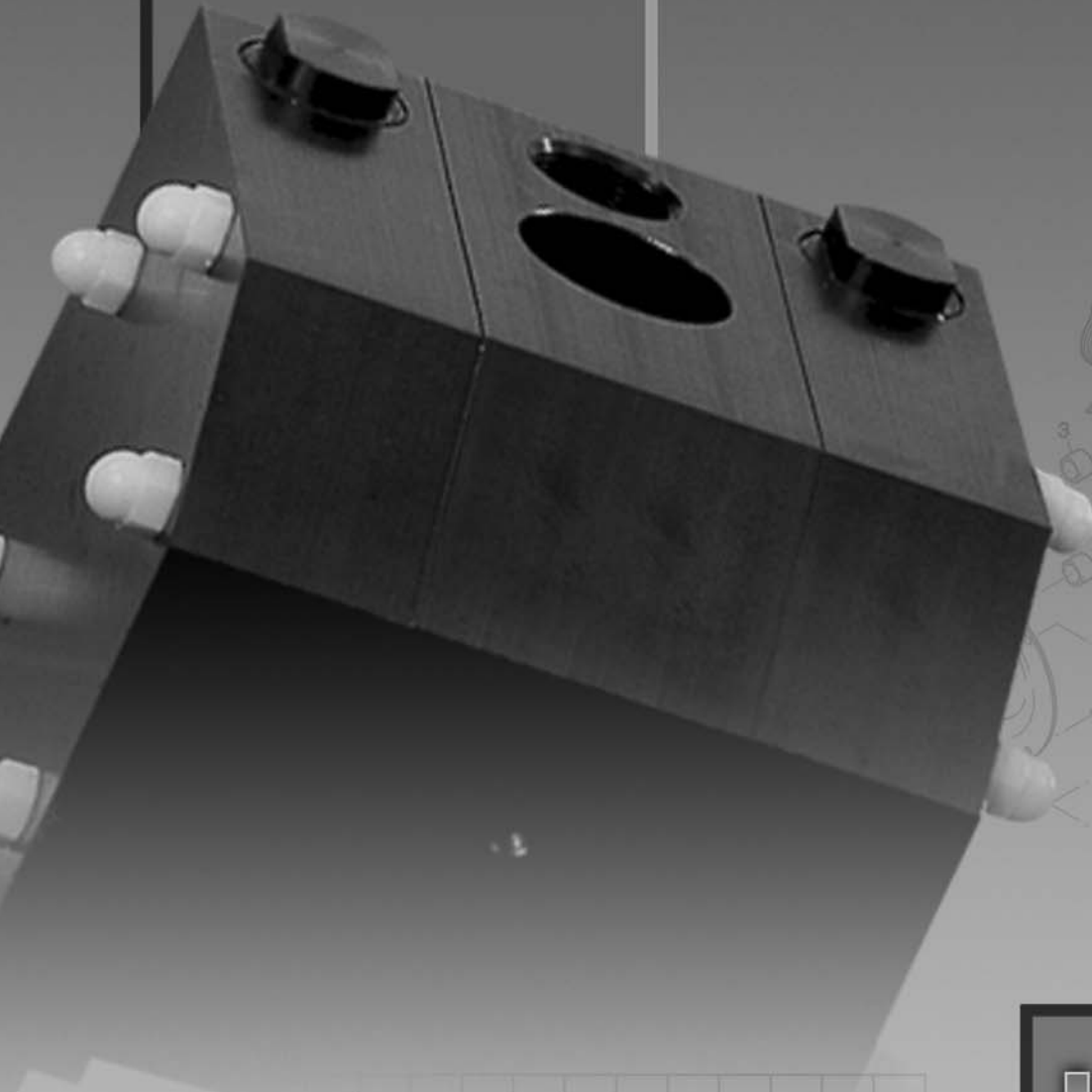

UNI-FLO™
PROGRESSIVE PUMP TECHNOLOGY

**Conductive
Plastic
Pumps**

TABLE OF CONTENTS

	PAGE #
SECTION 1 – PUMP DESIGNATION SYSTEM	1
SECTION 2 – HOW IT WORKS (PUMP & AIR SYSTEM)	2
SECTION 3 – CAUTIONS – READ FIRST!	3
SECTION 4 – DIMENSIONAL DRAWING	
A. Models UX.038, UX.050, UX.075 and UX3 Rubber/Teflon®-Fitted	4
SECTION 5 – PERFORMANCE CURVES	
A. Model UX.038 Rubber/Teflon®-Fitted	5
B. Model UX.050 Rubber/Teflon®-Fitted	5
C. Model UX.075 Rubber/Teflon®-Fitted	6
D. Model UX3 Rubber/Teflon®-Fitted	6
SECTION 6 – INSTALLATION & OPERATION	
A. Installation	7
B. Operation & Maintenance	8
C. Troubleshooting	9
SECTION 7 – DIRECTIONS FOR DISASSEMBLY/REASSEMBLY	
A. UNITEC™ UX Series Pumps	10
B. Reassembly Hints & Tips	13
SECTION 8 – EXPLODED VIEW/PARTS LISTING	
A. UNITEC™ UX Series Pump Drawing and Parts Listing	14



SECTION 1

WILDEN PUMP DESIGNATION SYSTEM

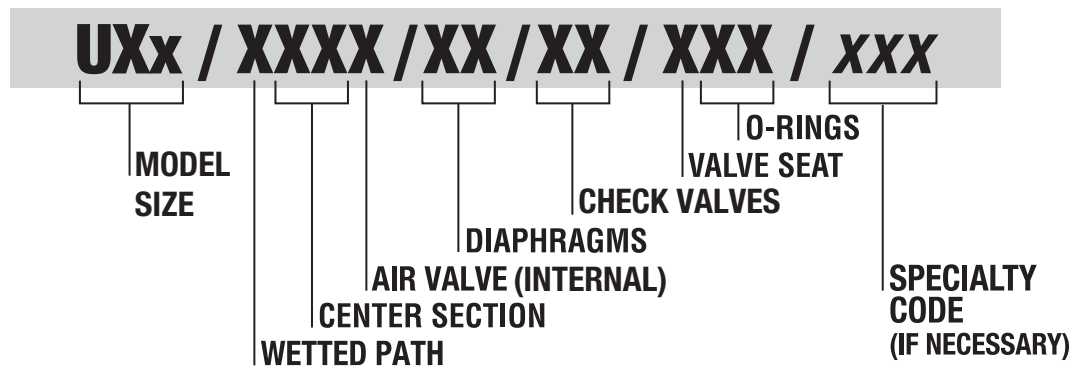

UNITEC™ SERIES CONDUCTIVE PLASTIC PUMP MATERIAL CODES

MODEL SIZES

UX.038	=	10 mm (3/8")
UX.050	=	13 mm (1/2")
UX.075	=	19 mm (3/4")
UX3	=	32 mm (1-1/4")

WETTED PATH

D	=	CONDUCTIVE POLYETHYLENE
---	---	-------------------------

CENTER SECTION

DD	=	CONDUCTIVE POLYETHYLENE
----	---	-------------------------

AIR VALVE

E	=	POLYETHYLENE
---	---	--------------

DIAPHRAGMS

ET	=	TEFLON® PTFE W/ INTEGRAL OUTER PISTON (White)
EX	=	NORDEL® W/INTEGRAL OUTER PISTON

CHECK VALVES

TF	=	TEFLON® PTFE (White) – BALL
ND	=	NORDEL® – BALL
SS	=	STAINLESS STEEL – BALL
CE	=	POLYETHYLENE – CYLINDER

VALVE SEATS

D	=	CONDUCTIVE POLYETHYLENE
---	---	-------------------------

VALVE SEAT O-RINGS

TV	=	TEFLON® ENCAP. VITON®
ND	=	NORDEL®

SPECIALTY CODES

812	Stroke sensor
814	Stroke counting pneumatic with pressure transmitter
816	Diaphragm sensor

SECTION 2

THE UNITEC™ PUMP — HOW IT WORKS

The Wilden UNITEC™ pump is an air-operated, positive displacement, self-priming pump. These drawings show the flow pattern through the pump upon its initial stroke. It is assumed the pump has no fluid in it prior to its initial stroke.

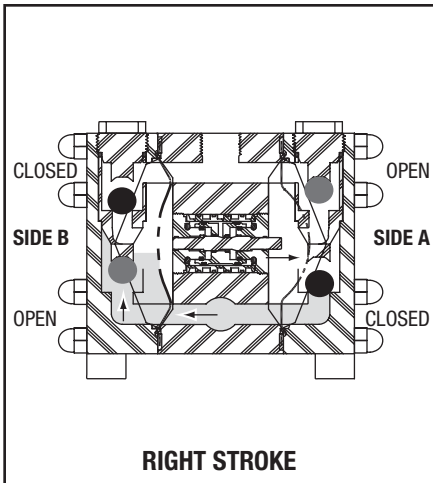

FIGURE 1: The air valve directs pressurized air to the back side of diaphragm A. The compressed air is applied directly to the liquid column separated by elastomeric diaphragms. The diaphragm acts as a separation membrane between the compressed air and liquid, balancing the load and removing mechanical stress from the diaphragm. The compressed air moves the diaphragm away from the center block of the pump. The opposite diaphragm is pulled in by the shaft connected to the pressurized diaphragm. Diaphragm B is on its suction stroke; air behind the diaphragm has been forced out to the atmosphere through the exhaust port of the pump. The movement of diaphragm B toward the center block of the pump creates a vacuum within chamber B. Atmospheric pressure forces fluid into the inlet manifold forcing the inlet valve ball off its seat. Liquid is free to move past the inlet valve ball and fill the liquid chamber (see shaded area).

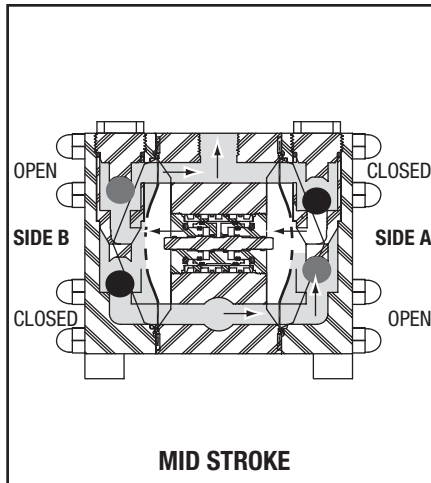

FIGURE 2: When the pressurized diaphragm, diaphragm A, reaches the limit of its discharge stroke, the air valve redirects pressurized air to the back side of diaphragm B. The pressurized air forces diaphragm B away from the center block while pulling diaphragm A to the center block. Diaphragm B is now on its discharge stroke. Diaphragm B forces the inlet valve ball onto its seat due to the hydraulic forces developed in the liquid chamber and manifold of the pump. These same hydraulic forces lift the discharge valve ball off its seat, while the opposite discharge valve ball is forced onto its seat, forcing fluid to flow through the pump discharge. The movement of diaphragm A toward the center block of the pump creates a vacuum within liquid chamber A. Atmospheric pressure forces fluid into the inlet manifold of the pump. The inlet valve ball is forced off its seat allowing the fluid being pumped to fill the liquid chamber.

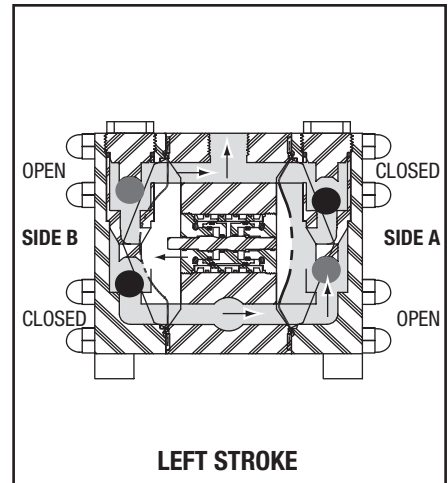

FIGURE 3: At completion of the stroke, the air valve again redirects air to the back side of diaphragm A, which starts diaphragm B on its exhaust stroke. As the pump reaches its original starting point, each diaphragm has gone through one exhaust and one discharge stroke. This constitutes one complete pumping cycle. The pump may take several cycles to completely prime depending on the conditions of the application.

THE UNI-FLO™ AIR SYSTEM — HOW IT WORKS





















The Uni-Flo™ air distribution system, the driving force behind UNITEC™ pumps, is assembled inside the center section of the pump, between the reciprocating diaphragms. The Uni-Flo™ systems uses a main air valve body and mechanically actuated pilot spool mechanism to direct inlet air pressure alternately behind each diaphragm while at the same time exhausting the air behind the opposite diaphragm to atmosphere. Air inlet pressure has a direct relation to the fluid discharge pressure that the pump can develop (head), while the volume of air has a direct relation to how quickly the pump will reciprocate (flow).

The pilot spool is pushed alternately left and right through contact with the inside of the diaphragm as it moves toward the center section on its exhaust stroke. The movement of the pilot spool from one side to the other changes the inlet and exhaust porting to each diaphragm by reversing the air flow behind each diaphragm. The diaphragm that pushed the pilot spool to shift the pump while on its exhaust stroke is now pressurized with inlet air pressure and pushed away from the center section displacing fluid.

This inherently safe design needs no electronic sensors or switches to operate reliably while delivering product. Speed and flow can be controlled with simple adjustments to the air regulator, air inlet valve or fluid system valves. The Uni-Flo™ system operates solely on compressed air and is simple to use, specify and operate.

SECTION 3**WILDEN UNITEC™
CONDUCTIVE PLASTIC PUMPS
CAUTIONS – READ FIRST!**

-  **CAUTION:** This pump is designed to run only on clean-dry air at all times. If oil and water may migrate into pump from air supply, a desiccant dryer must be installed.
-  **CAUTION:** Do not lubricate air supply — lubrication will reduce pump performance.
-  **TEMPERATURE LIMITS:**
- | | | |
|--------------|--------------------|----------------|
| Polyethylene | 0.0°C to 70.0°C | 32°F to 158°F |
| Nordel® | -51.1°C to 137.8°C | -60°F to 280°F |
| Teflon® PTFE | 4.4°C to 120°C | 40°F to 248°F |
-  **NOTE:** Conductive and unfilled plastics have the same temperature range and chemical resistance.
-  **CAUTION:** When choosing pump materials, be sure to check the temperature limits for all wetted components. Example: Nordel® has a maximum limit of 137.8°C (280°F) but polyethylene has a maximum limit of only 70.0°C (158°F).
-  **CAUTION:** Maximum temperature limits are based upon mechanical stress only. Certain chemicals will significantly reduce maximum safe operating temperatures. Consult Wilden Chem Guide (E-04) for chemical compatibility and temperature limits.
-  **CAUTION:** Always wear safety glasses and appropriate protection when operating pump. If diaphragm rupture occurs, material being pumped may be forced out air exhaust.
-  **WARNING:** Prevention of static sparking — If static sparking occurs, fire or explosion could result. Pump, valves, and containers must be grounded when handling flammable fluids and whenever discharge of static electricity is a hazard. To ground a UX series pump, utilize the marked grounding point on the face of the pump and connect to suitable grounding location. As each application has different requirements, please consult the local, regional or government regulatory agency for details on proper grounding for the application.
-  **CAUTION:** Do not exceed 7 bar (100 psig) air supply pressure.
-  **CAUTION:** Before any maintenance or repair is attempted, the compressed air line to the pump should be disconnected and all air pressure allowed to bleed from pump. Before disassembly of the pump, or removal from process lines, all pressure must also be bled from the liquid side of the pump and all fluid drained into a suitable container. Failure to do so may result in product under pressure being sprayed from system.
-  **CAUTION:** Blow out air line for 10 to 20 seconds before attaching to pump to make sure all pipeline debris is clear. A 5µ (micron) in-line air filter is recommended.
-  **CAUTION:** When installing diaphragms, be sure to insert the shaft stud into the outer piston first, tightening with a hex head wrench. Then proceed to install diaphragms on the end of shaft by rotating both diaphragms clockwise. If diaphragms are hand-tight on the shaft and the bolt holes do not line up, attempt to continue rotating clockwise until holes align, if possible. Reverse rotation to align holes only if it is impossible to align holes through clockwise rotation.
-  **NOTE:** Before starting disassembly, mark a line from each liquid chamber to its corresponding air chamber. This line will assist in proper alignment during reassembly.
-  **CAUTION:** The UX conductive plastic pumps are not submersible. If your application requires your pump to be submersed, contact the factory for details on a different Wilden pump model.
-  **CAUTION:** Pumps should be flushed thoroughly with water before installation into process line.
-  **CAUTION:** Tighten all hardware prior to installation.
-  **CAUTION:** Conductive resins may have up to 2% carbon filling. Ensure your process media is compatible with this filling.
-  **CAUTION:** Long-term exposure to UV rays may damage unfilled polyethylene. If located outside an unfilled polyethylene pump should be protected from UV rays.
-  **CAUTION:** Use caution not to overtighten air and liquid pipe connections, or pump fasteners. Overtorque of fittings or fasteners may damage the pump or cause leaking of process fluid.

SECTION 4A

DIMENSIONAL DRAWING WILDEN UNITEC™ CONDUCTIVE PLASTIC MODELS

DIMENSIONS FOR ALL UX SERIES PUMPS

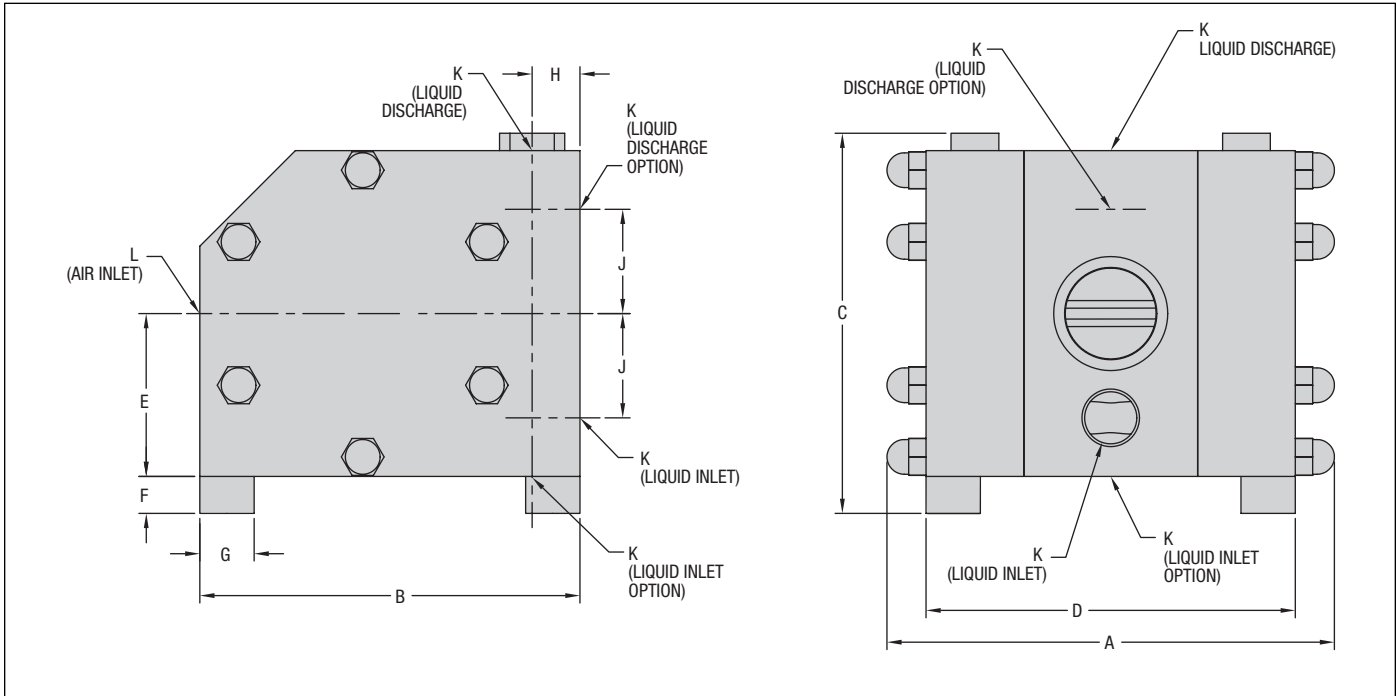

	UX.038	UX.050	UX.075	UX3
A	137 mm (5.4")	155 mm (6.1")	206 mm (8.1")	269 mm (10.6")
B	86 mm (3.2")	124 mm (4.9")	175 mm (6.9")	240 mm (9.5")
C	96 mm (3.8")	128 mm (5.0")	173 mm (6.8")	225 mm (8.9")
D	113 mm (4.5")	125 mm (4.9")	170 mm (6.7")	225 mm (8.9")
E	41 mm (1.6")	53 mm (2.1")	75 mm (3.0")	100 mm (3.9")
F	8 mm (0.3")	17 mm (0.7")	17 mm (0.7")	17 mm (0.7")
G	15 mm (0.6")	25 mm (1.0")	25 mm (1.0")	25 mm (1.0")
H	15 mm (0.6")	19 mm (0.8")	22 mm (0.9")	33 mm (1.3")
J	27 mm (1.1")	34 mm (1.3")	48 mm (1.9")	63 mm (2.5")
K	10 mm (3/8") FNPT/BSP	13 mm (1/2") FNPT/BSP	19 mm (3/4") FNPT/BSP	32 mm (1-1/4") FNPT/BSP
L	6 mm (1/4") FNPT/BSP	6 mm (1/4") FNPT/BSP	6 mm (1/4") FNPT/BSP	6 mm (1/4") FNPT/BSP

SECTION 5A

PERFORMANCE CURVES UX.038 CONDUCTIVE PLASTIC RUBBER/TEFLON®-FITTED

Height96 mm (3.8")
 Width137 mm (5.4")
 Depth86 mm (3.2")
 Ship Weight : Conductive
 Polyethylene1 kg (2 lbs)
 Air Inlet6 mm (¼") FNPT/BSP
 Inlet10 mm (⅜") FNPT/BSP
 Discharge10 mm (⅜") FNPT/BSP
 Suction Lift1.5 m (4.9') Dry'
 8.0 m (26.2') Wet

*Max. dry suction is achieved when pump is fitted with cylinder check valves.

Sound: Max. dBA 83
 Displacement Per Stroke 0.008 l (0.002 gal)¹
 Maximum Viscosity3,000 cP
 Max. Flow Rate10.0 lpm (2.6 gpm)
 Max. Size Solids1.5 mm (0.06")
¹Displacement per stroke was calculated at 6.9 bar (100 psig) air inlet pressure against 0 bar (0 psig) head pressure.

Example: To pump 5.7 lpm (1.5 gpm) against a discharge pressure head of 2.3 bar (33 psig) requires 5.5 bar (80 psig) and 5.1 Nm³/h (3.0 scfm) air consumption. (See dot on chart.)

Caution: Do not exceed 7 bar (100 psig) air inlet supply pressure.

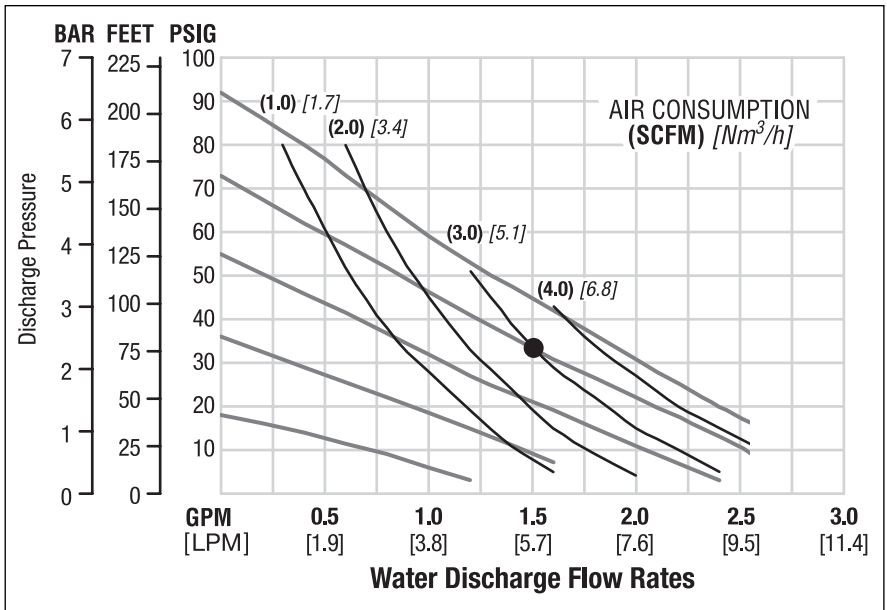

Flow rates indicated on chart were determined by pumping water.

For optimum life and performance, pumps should be specified so that daily operation parameters will fall in the center of the pump performance curve.

SECTION 5B

PERFORMANCE CURVES UX.050 CONDUCTIVE PLASTIC RUBBER/TEFLON®-FITTED

Height128 mm (5.0")
 Width155 mm (6.1")
 Depth124 mm (4.9")
 Ship Weight: Conductive
 Polyethylene2 kg (4 lbs)
 Air Inlet6 mm (¼") FNPT/BSP
 Inlet13 mm (½") FNPT/BSP
 Discharge13 mm (½") FNPT/BSP
 Suction Lift2.0 m (6.6') Dry'
 8.0 m (26.2') Wet

*Max. dry suction is achieved when pump is fitted with cylinder check valves.

Sound: Max. dBA 83
 Displacement Per Stroke 0.026 l (0.007 gal)¹
 Maximum Viscosity6,000 cP
 Max. Flow Rate20.0 lpm (5.3 gpm)
 Max. Size Solids2.0 mm (0.08")
¹Displacement per stroke was calculated at 6.9 bar (100 psig) air inlet pressure against 0 bar (0 psig) head pressure.

Example: To pump 7.6 lpm (2.0 gpm) against a discharge pressure head of 2.5 bar (36 psig) requires 4.1 bar (60 psig) and 1.7 Nm³/h (1.0 scfm) air consumption. (See dot on chart.)

Caution: Do not exceed 7 bar (100 psig) air inlet supply pressure.

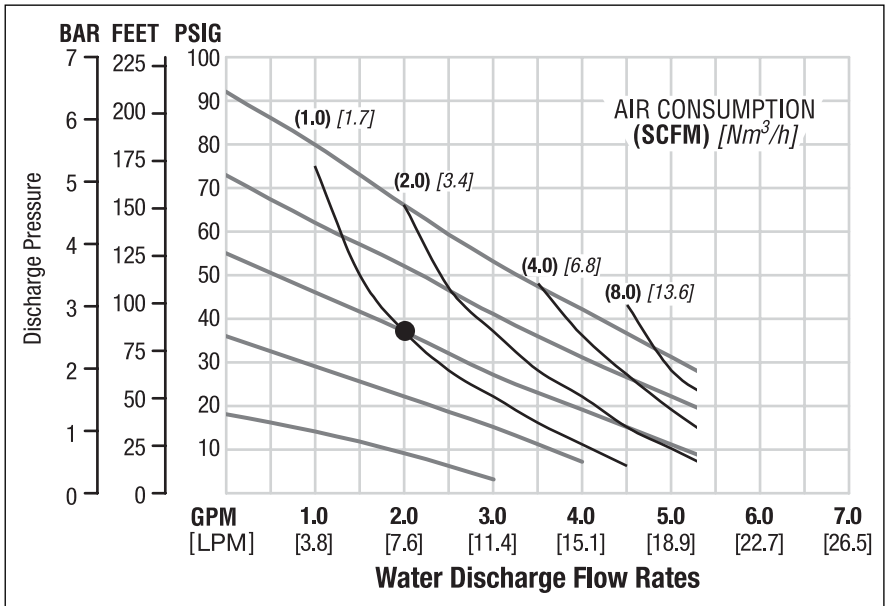

Flow rates indicated on chart were determined by pumping water.

For optimum life and performance, pumps should be specified so that daily operation parameters will fall in the center of the pump performance curve.

SECTION 5C

PERFORMANCE CURVES

UX.075 CONDUCTIVE PLASTIC RUBBER/TEFLON® FITTED

Height173 mm (6.8")
 Width206 mm (8.1")
 Depth175 mm (6.9")
 Ship Weight: Conductive
 Polyethylene5 kg (11 lbs)
 Air Inlet6 mm (1/4") FNPT/BSP
 Inlet19 mm (3/4") FNPT/BSP
 Discharge19 mm (3/4") FNPT/BSP
 Suction Lift3.0 m (9.8') Dry¹
 9.0 m (29.5') Wet

¹Max. dry suction is achieved when pump is fitted with cylinder check valves.

Sound: Max. dBA 83
 Displacement Per Stroke 0.110 l (0.029 gal)¹
 Maximum Viscosity10,000 cP
 Max. Flow Rate50.0 lpm (13.2 gpm)
 Max. Size Solids3.0 mm (0.12")
 ¹Displacement per stroke was calculated at 6.9 bar (100 psig) air inlet pressure against 0 bar (0 psig) head pressure.

Example: To pump 17 lpm (4.5 gpm) against a discharge pressure head of 4.3 bar (62 psig) requires 5.5 bar (80 psig) and 10.2 Nm³/h (6.0 scfm) air consumption. (See dot on chart.)

Caution: Do not exceed 7 bar (100 psig) air inlet supply pressure.

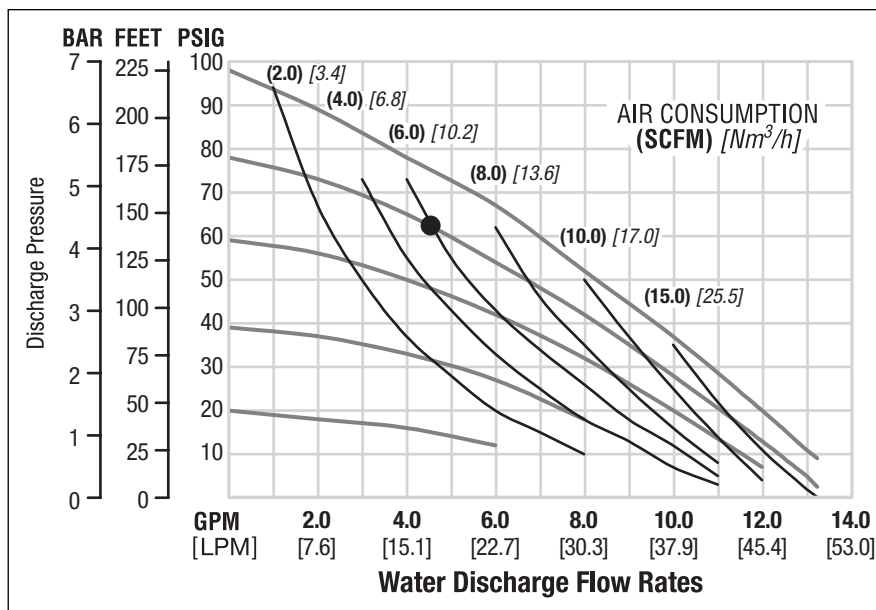

Flow rates indicated on chart were determined by pumping water.

For optimum life and performance, pumps should be specified so that daily operation parameters will fall in the center of the pump performance curve.

SECTION 5D

PERFORMANCE CURVES

UX3 CONDUCTIVE PLASTIC RUBBER/TEFLON® FITTED

Height225 mm (8.9")
 Width269 mm (10.6")
 Depth240 mm (9.5")
 Ship Weight: Conductive
 Polyethylene10 kg (22 lbs)
 Air Inlet6 mm (1/4") FNPT/BSP
 Inlet32 mm (1-1/4") FNPT/BSP
 Discharge32 mm (1-1/4") FNPT/BSP
 Suction Lift4.0 m (13.1') Dry¹
 9.0 m (29.5') Wet

¹Max. dry suction is achieved when pump is fitted with cylinder check valves.

Sound: Max. dBA 83
 Displacement Per Stroke 0.330 l (0.087 gal)¹
 Maximum Viscosity15,000 cP
 Max. Flow Rate130 lpm (34 gpm)
 Max. Size Solids4.0 mm (0.16")
 ¹Displacement per stroke was calculated at 6.9 bar (100 psig) air inlet pressure against 0 bar (0 psig) head pressure.

Example: To pump 91 lpm (24 gpm) against a discharge pressure head of 1.2 bar (18 psig) requires 4.1 bar (60 psig) and 26 Nm³/h (15 scfm) air consumption. (See dot on chart.)

Caution: Do not exceed 7 bar (100 psig) air inlet supply pressure.

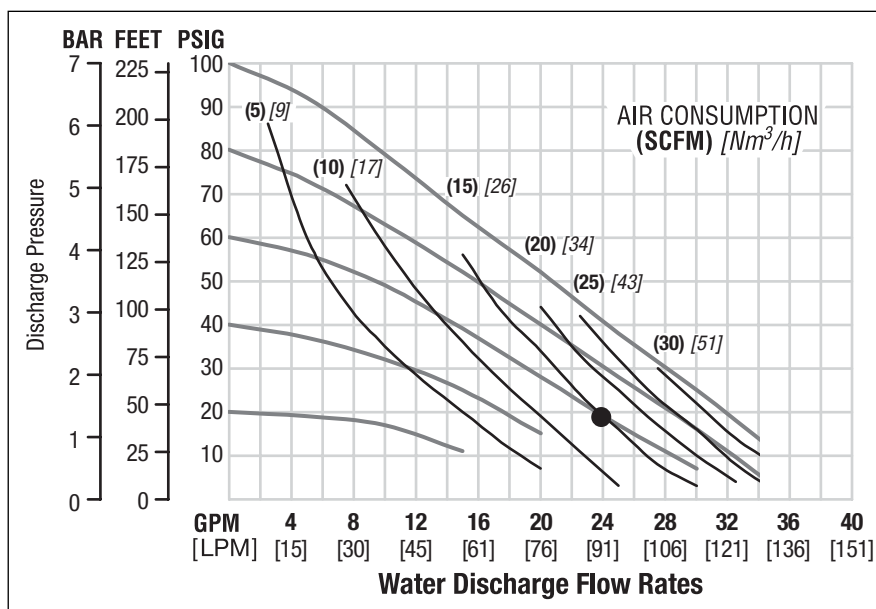

Flow rates indicated on chart were determined by pumping water.

For optimum life and performance, pumps should be specified so that daily operation parameters will fall in the center of the pump performance curve.

SECTION 6A**INSTALLATION
UX SERIES CONDUCTIVE PLASTIC PUMPS**

The UX conductive plastic pumps are manufactured with wetted parts of conductive (less than 2% carbon filled) polyethylene. The UX pumps are constructed with a conductive polyethylene center housing. A variety of diaphragms and o-rings are available to satisfy temperature, chemical compatibility, abrasion and flex concerns.

The suction pipe size for all installations should be as large as the pump inlet, or larger if highly viscous material is being pumped. The suction hose must be a non-collapsible reinforced type, as the UX pumps are capable of pulling a high vacuum. Discharge piping should be as large as the pump discharge, however, larger diameter pipe may be used to reduce friction losses. It is critical that all fittings and connections are airtight or a reduction or loss of pump suction capability will result. For all UX models, Wilden offers FNPT/BSP liquid and air connections.

UX series pumps offer variable air and fluid connection configurations. The optional connection configuration can be achieved by inverting the center section without affecting pump performance.

INSTALLATION: Months of careful planning, study, and selection efforts can result in unsatisfactory pump performance if installation details are left to chance. Premature failure and long term dissatisfaction can be avoided if reasonable care is exercised throughout the installation process.

LOCATION: Noise, safety, and other logistical factors usually dictate where equipment be situated on the production floor. Multiple installations with conflicting requirements can result in congestion of utility areas, leaving few choices for additional pumps. Within the framework of these and other existing conditions, every pump should be located in such a way that key factors are balanced against each other to maximum advantage.

ACCESS: First of all, the location should be accessible. If it's easy to reach the pump, maintenance personnel will have an easier time carrying out routine inspections and adjustments. Should major repairs become necessary, ease of access can play a key role in speeding the repair process and reducing total downtime.

AIR SUPPLY: Every pump location should have an air line large enough to supply the volume of air necessary to achieve the desired pumping rate (see Section 5). Use air pressure up to a maximum of 7 bar (100 psig) depending on pumping requirements. For best results, the pumps should use a 5 μ (micron) air filter, needle valve and regulator. The pumps should also be run on clean-dry air only at all times. If this is not possible, a desiccant dryer must be installed and continually maintained on the air inlet to prevent migration of condensation or air line oil into the air system. The use of an air filter before the pump will insure that the majority of any pipeline contaminants will be eliminated. Sound levels are reduced below OSHA specifications using the standard Wilden muffler element supplied with pump.

ELEVATION: Selecting a site that is well within the pump's dynamic lift capability will assure that loss-of-prime troubles will be eliminated. In addition, pump efficiency can be adversely affected if proper attention is not given to site location.

PIPING: Final determination of the pump site should not be made until the piping problems of each possible location have been evaluated. The impact of current and future installations should be considered ahead of time to make sure that inadvertent restrictions are not created for any remaining sites.

The best choice possible will be a site involving the shortest and straightest hook-up of suction and discharge piping. Unnecessary elbows, bends, and fittings should be avoided. Pipe sizes should be selected to keep friction losses within practical limits. All piping should be supported independently of the pump. In addition, the piping should be aligned to avoid placing stresses on the pump fittings.

Flexible hose can be installed to aid in absorbing the forces created by the natural reciprocating action of the pump. Flexible connections between the pump and rigid piping will also assist in minimizing pump vibration. If quick-closing valves are installed at any point in the discharge system, or if pulsation within a system becomes a problem, a conductive SD pulsation dampener should be installed to protect the pump, piping and gauges from surges and water hammer.

Valves should be installed in the suction and discharge lines to permit closing of the lines for pump service. The use of isolation valves prevents the media being pumped from flowing back into the pump and out any loosened connections. Note: When inlet and discharge valves are closed, pressure may still remain trapped in the pump and piping. Use caution when performing any maintenance on the pump. Be sure to properly drain all air and liquid pressure from the pump before servicing.

Proper care should always be taken to ensure a tight liquid and air seal for all installations. If the pump is to be used in a self-priming application, be sure that all connections are airtight and that the suction lift is within the model's ability. Note: Materials of construction and elastomer material have an effect on suction lift parameters. Please consult Wilden distributors for specifics.

Pumps in service with a positive suction head are most efficient when inlet pressure is limited to 0.5–0.7 bar (7–10 psig). Premature diaphragm failure may occur if positive suction is higher than 0.7 bar (10 psig).

THE MODEL UX SERIES PUMPS HAVE LIMITED SOLIDS PASSAGE CAPABILITY. WHENEVER THE POSSIBILITY EXISTS THAT LARGER SOLID OBJECTS MAY BE SUCKED INTO THE PUMP, A STRAINER SHOULD BE USED ON THE SUCTION LINE. (See Section 5 for Max. Size Solids.)

CAUTION: DO NOT EXCEED 7 BAR (100 PSIG) AIR SUPPLY PRESSURE.

UX PUMPS CANNOT BE SUBMERGED. FOR SUBMERGED APPLICATIONS, CONTACT THE FACTORY FOR AN ALTERNATIVE WILDEN MODEL.

SUGGESTED INSTALLATION

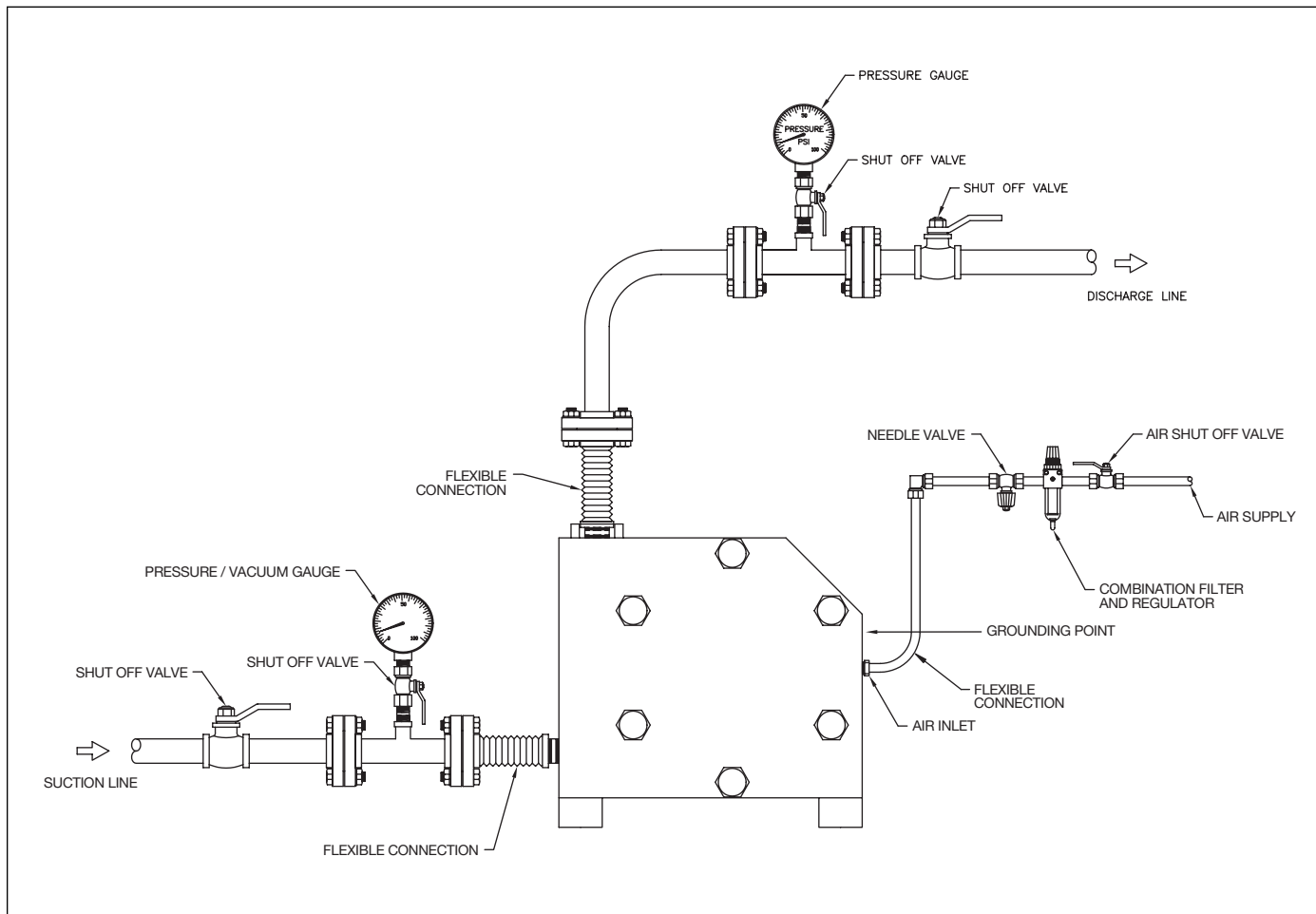

SECTION 6B

SUGGESTED OPERATION AND MAINTENANCE INSTRUCTIONS

OPERATION: UX pumps do not require in-line lubrication. Lubrication will damage the pump! If the pump is lubricated by an external source, the pump's internal seals may be damaged causing premature failure of the pump.

Pump discharge rate can be controlled by limiting the volume and/or pressure of the air supply to the pump (preferred method). An air regulator is used to regulate air pressure. A needle valve is used to regulate volume. Pump discharge rate can also be controlled by throttling the pump discharge by partially closing a valve in the discharge line of the pump. This action increases friction loss which reduces flow rate. This is useful when the need exists to control the pump from a remote location. When the pump discharge pressure equals or exceeds the air supply pressure, the pump will stop; no bypass or pressure relief valve is needed, and pump damage will not occur. The pump has reached a "deadhead" situation and can be restarted by reducing the fluid discharge pressure or increasing the air inlet pressure. The Wilden UX pump runs solely on clean-dry air and generates little heat, therefore your process fluid temperature will not be affected.

MAINTENANCE AND INSPECTIONS: Since each application is unique, maintenance schedules may be different for every pump. Frequency of use, line pressure, viscosity and abrasiveness of process fluid all affect the parts life of a Wilden pump. Periodic inspections have been found to offer the best means for preventing unscheduled pump downtime. Personnel familiar with the pump's construction and service should be informed of any abnormalities that are detected during operation. Read all cautions before performing any service on a Wilden pump.

RECORDS: When service is required, a record should be made of all necessary repairs and replacements. Over a period of time, such records can become a valuable tool for predicting and preventing future maintenance problems and unscheduled downtime. In addition, accurate records make it possible to identify pumps that are poorly suited to their applications.

SECTION 6C

TROUBLESHOOTING

Pump will not run or runs slowly.

1. Ensure that the air inlet pressure is at least 0.4 bar (5 psig) above startup pressure and that the differential pressure (the difference between air inlet and liquid discharge pressures) is not less than 0.7 bar (10 psig).
2. Check air inlet filter for debris (see recommended installation). A 5 μ (micron) air filter must be installed in the air inlet line of the pump to prevent air line particulate from entering and damaging air system.
3. Check for extreme air leakage (blow by) which would indicate worn seals/bores in the air valve, pilot spool and main shaft.
4. Disassemble pump and check for obstructions in the air passage-ways or objects which would obstruct the movement of internal parts.
5. Check for sticking ball check valves. If material being pumped is not compatible with pump elastomers, swelling may occur. Replace ball check valves and seals with proper elastomers. Also, as the check valve balls wear out, they become smaller and can become stuck in the seats. In this case, replace balls and seats.
6. Diaphragms may have a pinhole allowing air to escape to the liquid side of the pump reducing performance. Check and replace diaphragms as necessary.
7. Air valve may have debris from inlet air system. A 5 μ (micron) air filter must be installed in the air inlet line of the pump to prevent air line particulate from entering and damaging air system.

Pump does not run.

1. Air supply line or discharge fluid line is blocked or a valve is closed. Check valves for system and ensure they are set as desired, or disassemble pump and check for blockage.
2. Muffler may be blocked with debris or other contaminants. This will prevent air from exhausting. Replace muffler.

Pump runs and then stops with no external visible reason.

1. Ice within the air system may be blocking a port. Check system for blockage and add a dryer in air inlet line to prevent moisture from entering air system.
2. System air pressure may have dropped below system requirements. This will not hurt the pump but will put the pump into a dead-head condition. The pump will restart once air supply pressure is increased or discharge head decreases below air inlet pressure.
3. Air system may have become blocked by debris. A 5 μ (micron) air filter must be installed in the air inlet line of the pump to prevent air line particulate from entering and damaging air system.
4. Air system may need maintenance. Disassemble pump and replace worn parts as necessary.
5. Diaphragm has ruptured and the product being pumped has flooded the air system stalling the pump. Disassemble the pump, clean air system of process fluid and replace diaphragms.
6. Air inlet line filter may be blocked with debris not allowing enough volume into pump for proper operation. Check and replace air inlet filter as necessary. A 5 μ (micron) air filter must be installed in the air inlet line of the pump to prevent air line particulate from entering and damaging air system.

Pump runs but discharge flow decreases over time.

1. Ice within the air system may be reducing air flow in the pump. Check system for blockage and add a dryer in air inlet line to prevent moisture from entering air system.
2. Check air inlet line pressure to confirm a pressure drop has not occurred. If air pressure has decreased, locate the source of the air pressure loss and correct.
3. Debris from the air inlet line may have migrated into air system prematurely wearing the seals. Disassemble pump and replace parts as necessary. A 5 μ (micron) air filter must be installed in the air inlet line of the pump to prevent air line particulate from entering and damaging air system.

Product comes out air exhaust.

1. Check for diaphragm rupture.

Pump runs but little or no product flows.

1. Check for pump cavitation; slow pump speed down to allow thick material to flow into the liquid chambers.
2. Verify that vacuum required to lift liquid is not greater than the vapor pressure of the material being pumped (cavitation).
3. Check for sticking ball check valves. If material being pumped is not compatible with pump elastomers, swelling may occur. Replace ball check valves and seals with proper elastomers. Also, as the check valve balls wear out, they become smaller and can become stuck in the seats. In this case, replace balls and seats.
4. Pump may be operating too fast. Often to prime the pump, especially when at the maximum capability of the pump with the system design, you must lower the air inlet pressure to achieve maximum suction lift. Once primed, line pressure can be raised to meet system requirements.
5. Abrasives in the product have deteriorated the valve ball or check valve and a good seal against the valve seat is no longer being achieved. Disassemble pump and replace worn parts as necessary.
6. Ensure a vacuum is not present inside the source fluid container. Check that the tank/tote vent is open and air is allowed into the tank/tote as product is being removed.
7. Check suction line for leaks and tight connections. In the event a union is loose the pump will be unable to pull the product efficiently into the pump. Tighten any loose suction line connections.
8. Check EOM for details on suction capabilities and ensure the system design is within the suction capabilities of the pump.

Pump air valve freezes.

1. Condensation from the air line is most likely bypassing the desiccant dryer or the dryer is beyond its useful life. Replace/service dryer.
2. No dryer is installed ahead of pump, allowing moisture into air system. This will damage air system and may render it inoperable. Install a desiccant dryer on the air inlet line with a 5 μ (micron) air filter.

Air bubbles in pump discharge.

1. Check for ruptured diaphragm.
2. Check tightness of housing bolts and integrity of o-rings and seals, especially at intake manifold.
3. Ensure pipe connections are airtight.

Pump leaks between center section and liquid chambers.

1. Tighten all tie rods on pump to ensure a tight fit with the center section.
2. The o-rings on the sleeves between the liquid chambers and center section may be damaged. Disassemble pump and check o-rings for damage and replace as necessary.
3. Diaphragms and/or o-rings may have been damaged due to incompatibility with chemical being pumped. Check chemical use chart and select a material more appropriate for the process fluid.
4. Sleeves between center section and liquid chambers may be damaged during maintenance. Disassemble pump and replace worn or damaged parts as necessary.

SECTION 7A

UX CONDUCTIVE PLASTIC PUMPS DIRECTIONS FOR DISASSEMBLY/REASSEMBLY

CAUTION: Before any maintenance or repair is attempted, the compressed air line to the pump should be disconnected and all air pressure allowed to bleed from the pump. Use extreme caution as the pump liquid path may still be under pressure even though air line is disconnected. Disconnect all intake, discharge, and air lines. Drain the pump by turning it upside down and allowing any fluid to flow into a suitable container. Be aware of any hazardous effects of contact with your process fluid.

The UX conductive plastic pumps are available with conductive polyethylene wetted parts.

TOOLS REQUIRED:

Metric Socket Wrench Set
Metric Open-end / Box-end Wrench Set
Adjustable Wrench
Medium Flat Head Screwdriver
Air Valve Tool Included with Pump

NOTE: The model used for these instructions incorporates Teflon® diaphragms, balls, and seat o-rings. Models with rubber diaphragms and balls are the same except where noted.

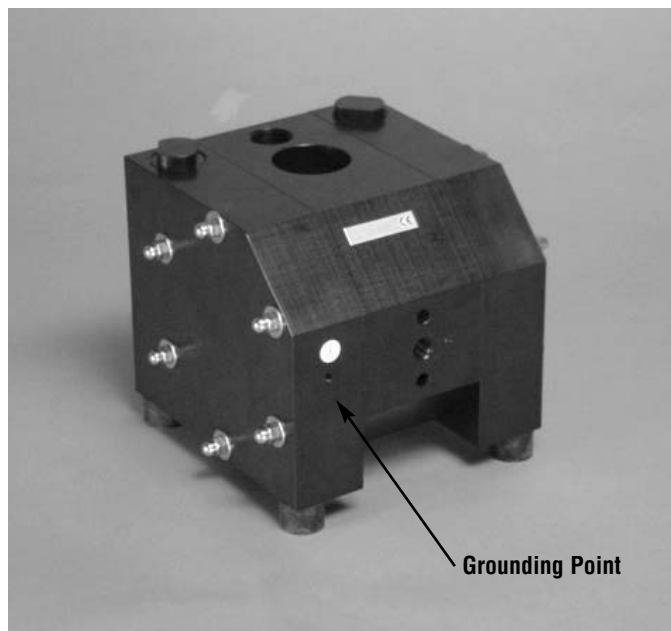

DISASSEMBLY:

STEP 1.

Figure 1

Before disassembly, note orientation of center housing. This portion of the pump is reversible and noting direction now may prevent additional assembly time later. Remove muffler by turning counter-clockwise by hand.

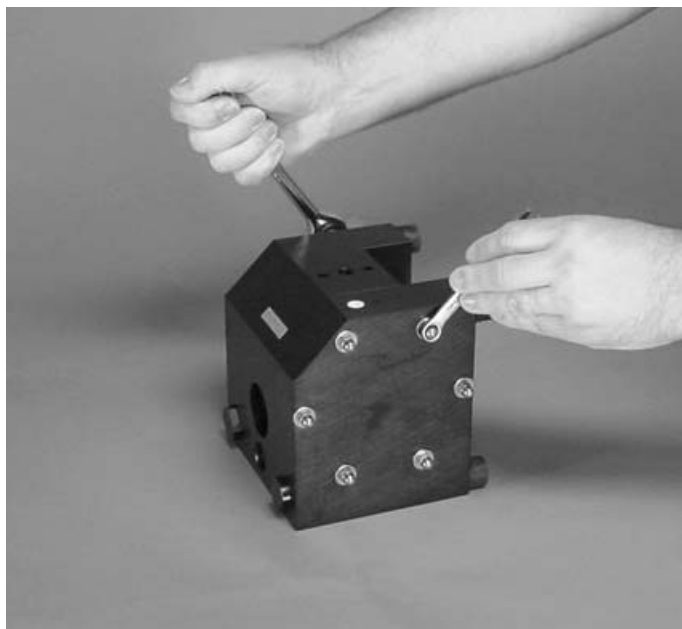

STEP 2.

Figure 2

Place pump on back side (where muffler was removed). Utilizing a metric socket and box wrench, loosen and remove cap nut, washers, and tie rods.

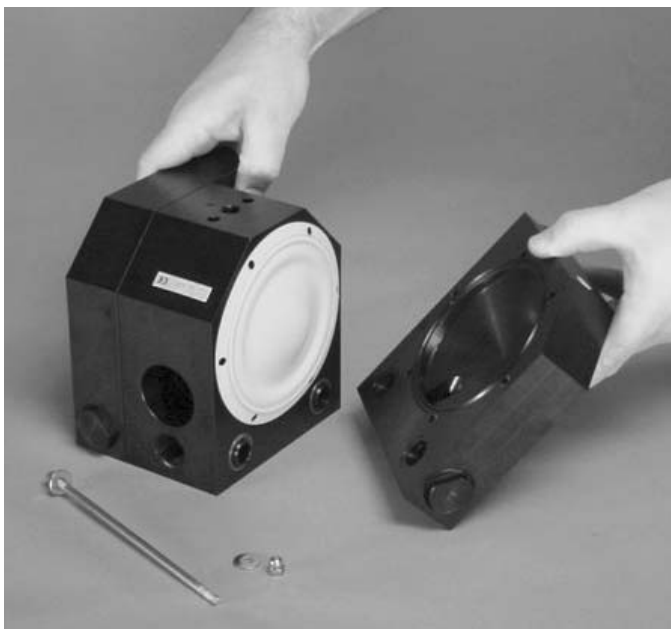

STEP 3.

Figure 3

Remove the two liquid chambers from center housing by gently pulling apart by hand. The use of a screwdriver or other tool may damage center housing or liquid chambers, preventing proper reassembly.

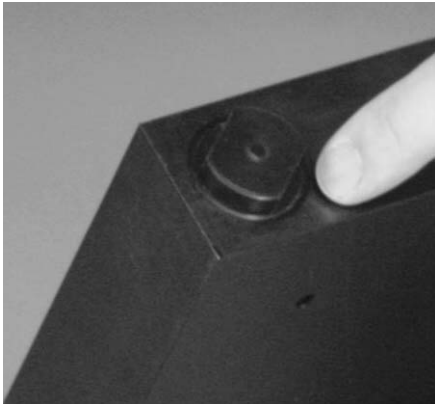

STEP 4. *Figure 4*

REASSEMBLY NOTE: When reinstalling top retainers, be sure not to over tighten as this may reduce pump performance. The edge of the retainer, under the wrench landing, must be flush with the top of the liquid chamber.

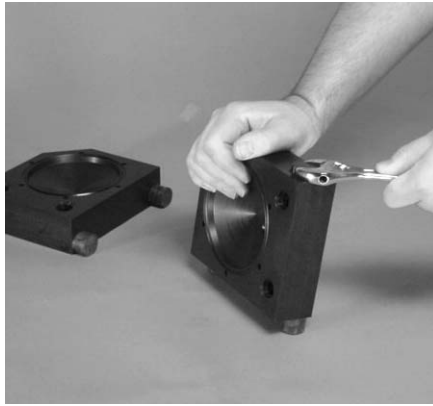

STEP 5. *Figure 5*

Remove top retainers from both liquid chambers using an adjustable wrench.

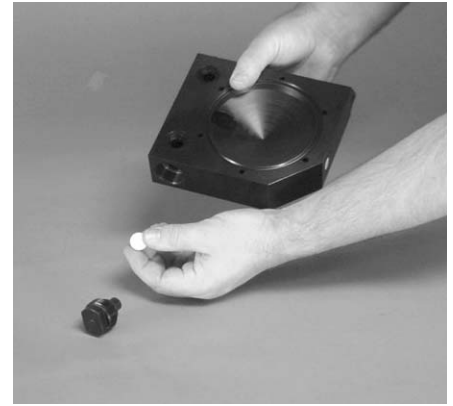

STEP 6. *Figure 6*

Remove and inspect valve ball and top retainer for wear or damage. Replace with genuine Wilden parts when required.

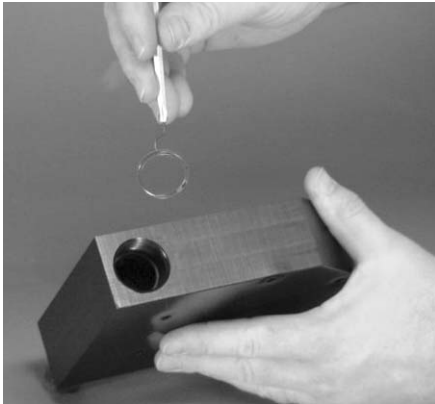

STEP 7. *Figure 7*

Remove and inspect top retainer o-ring for wear or damage. It is located on a landing just under the threads for the top retainer. Replace with genuine Wilden parts when required.

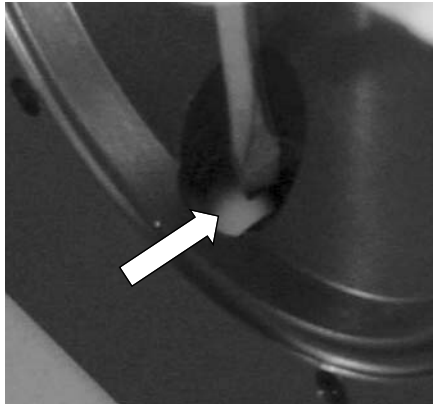

STEP 8. *Figure 8*

Remove the valve housing from the liquid chamber by using a medium-sized flat head screwdriver to gently pry it up. The screwdriver is placed through a hole located in the liquid chamber in an opening just above the inlet valve ball.

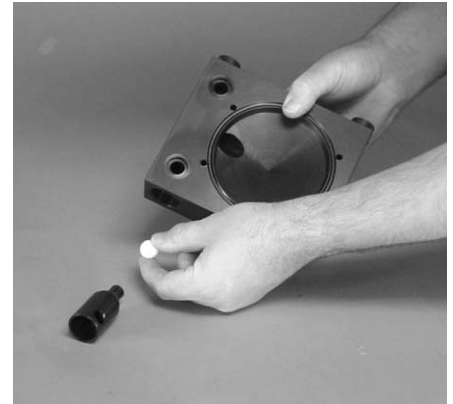

STEP 9. *Figure 9*

Remove the valve housing and inlet valve ball from the liquid chamber and inspect for wear or damage. Replace with genuine Wilden parts when required.

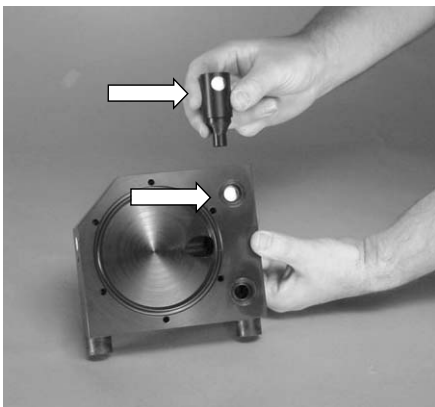

STEP 10. *Figure 10*

REASSEMBLY NOTE: When reinstalling valve housing, be sure to align hole in side of valve housing with fluid port in liquid chamber. If inserted incorrectly, fluid will not pass to the discharge of the pump.

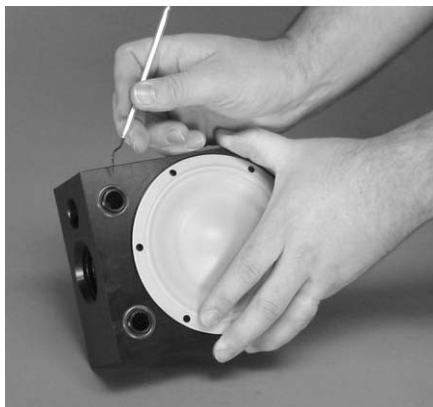

STEP 11. *Figure 11*

Four o-rings are located on the inlet and discharge ports of the center assembly (two on each side). Inspect and replace if necessary to ensure leak-free operation. Note: If o-ring is removed, it must be replaced with a new o-ring.



STEP 12. *Figure 12*

Grasp edge of each diaphragm. Turn counter-clockwise to loosen and remove one diaphragm. Pull diaphragm with shaft attached to it out of center housing. Remove diaphragm from shaft. Inspect and replace diaphragms as needed.

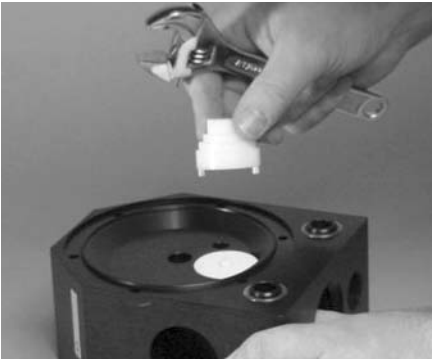

STEP 13. *Figure 13*

Use tool shipped with pump to remove Uni-Flo™ end caps (one on each side) from center assembly.



STEP 14. *Figure 14*

Turn tool counterclockwise to loosen. Use caution not to force it as the small pins on the removal tool can shear off. If one side is not coming loose, turn over and try the second side.



STEP 15. *Figure 15*

After removing the Uni-Flo™ end caps, remove pilot pin and o-ring. Inspect for damage. If air valve internals are damaged or worn, a complete Uni-Flo™ air valve assembly must be purchased as a replacement.



STEP 16. *Figure 16*

Place tool such that pins are sticking upward and push the valve out the bottom end with your thumbs (you may need to use a rubber mallet to gently tap the tool to initiate movement.) Do not hit the valve directly with a tool.



STEP 17. *Figure 17*

Take apart Uni-Flo™ air valve with your fingers. Inspect o-rings and seals and replace entire assembly if required.

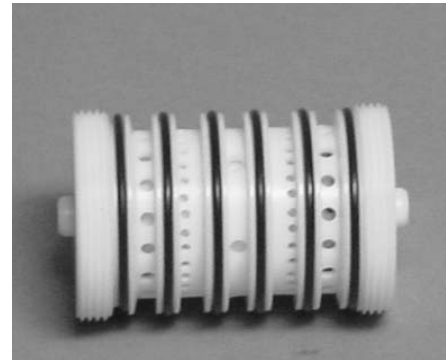

STEP 18. *Figure 18*

Complete air valve assembly.

SECTION 7B**REASSEMBLY HINTS & TIPS**

When reassembling a UX series pump, it is important to pay particular attention to specific details to avoid damaging the pump or limiting pump performance. To reassemble a UX pump follow disassembly instructions 1 through 18 in reverse order and be sure to adhere to the following assembly hints & tips:

1. Before installing or inserting any components, moisten all parts with distilled water for lubrication. DO NOT use any oil or silicone lubricants as these may damage the pump or render it inoperable.
2. When tightening the air valve end into the center section, be sure to use the tool included with pump upon arrival.
3. Continue to tighten the air valve ends until the top of the end cap is flush with the center housing.
4. To prevent damage to o-rings in center block from being damaged upon insertion, carefully fold into a kidney shape before insertion. (See figure.) After insertion, carefully smooth o-rings with a tie rod before inserting shaft.
5. When reattaching diaphragms to the shaft, first insert and tighten the shaft stud into the diaphragm piston using a hex head wrench. Then proceed to hand-tighten onto end of shaft.
6. When installing diaphragms, be sure to insert the shaft stud into the outer piston first, tightening with a hex head wrench. (Note: UX.038 and UX.050 have an integral stud on diaphragm.) Then proceed to install diaphragms on the end of shaft by rotating both diaphragms clockwise. If diaphragms are hand-tight on the shaft and the bolt holes do not line up, alternate to continue rotating clockwise until holes align if possible. Reverse rotation to align holes only if it is impossible to align holes through clock-wise rotation.
7. When reinstalling valve housing, be sure to align hole in side of valve housing with fluid port in liquid chamber. If inserted incorrectly fluid will not pass to the discharge of the pump. Remember to insert inlet valve ball into liquid chamber before installing valve housing.
8. After reinserting discharge valve ball, reinstall top retainers. Be sure not to over-tighten as this may reduce pump performance. The edge of the retainer, under the wrench landing, must be flush with the top of the liquid chamber.
9. Reassemble both liquid chambers against the center housing, aligning all bolt holes. Insert all tie rods and install all cap nuts and washers. Be sure the Belleville washers have the concave side of the washer facing toward the center housing. Continue to tighten until all three pieces meet tightly, but do not over-tighten. Over-torque of the tie rod cap nuts will cause pump damage.
10. To prevent seizing of hardware upon reassembly, spray an anti-seize Teflon® lubricant on the tie-rod threads before tightening.

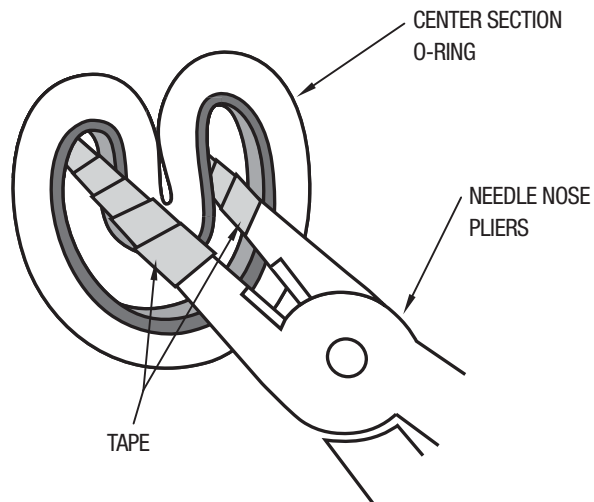

SECTION 8A

EXPLODED VIEW / PARTS LISTING

UX.038 and UX.050 Pumps

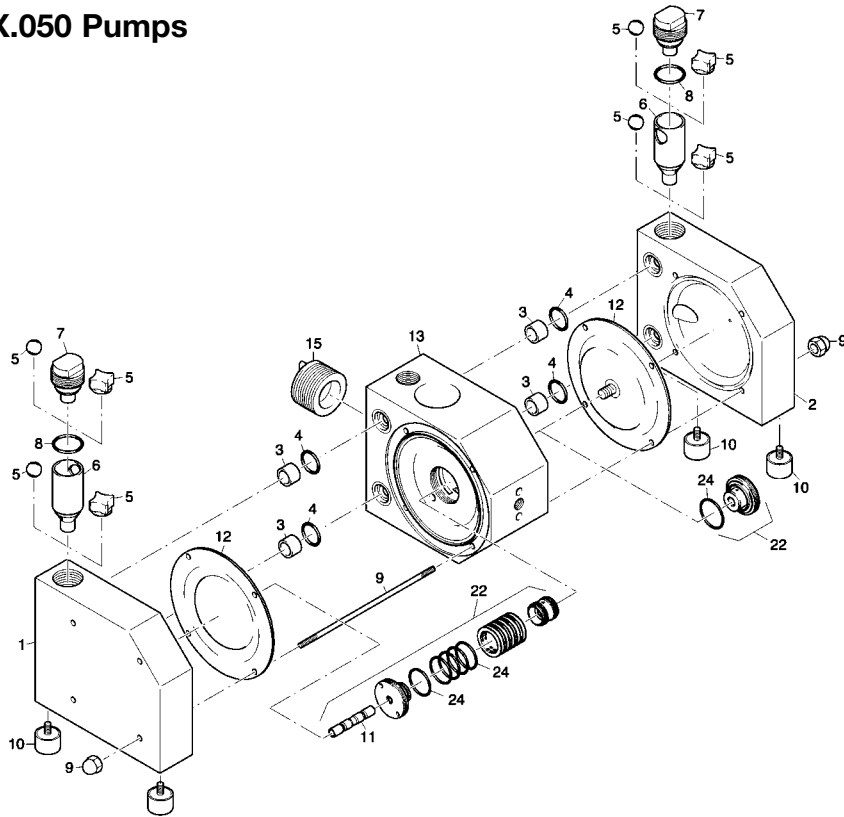

UX.075 and UX3 Pumps

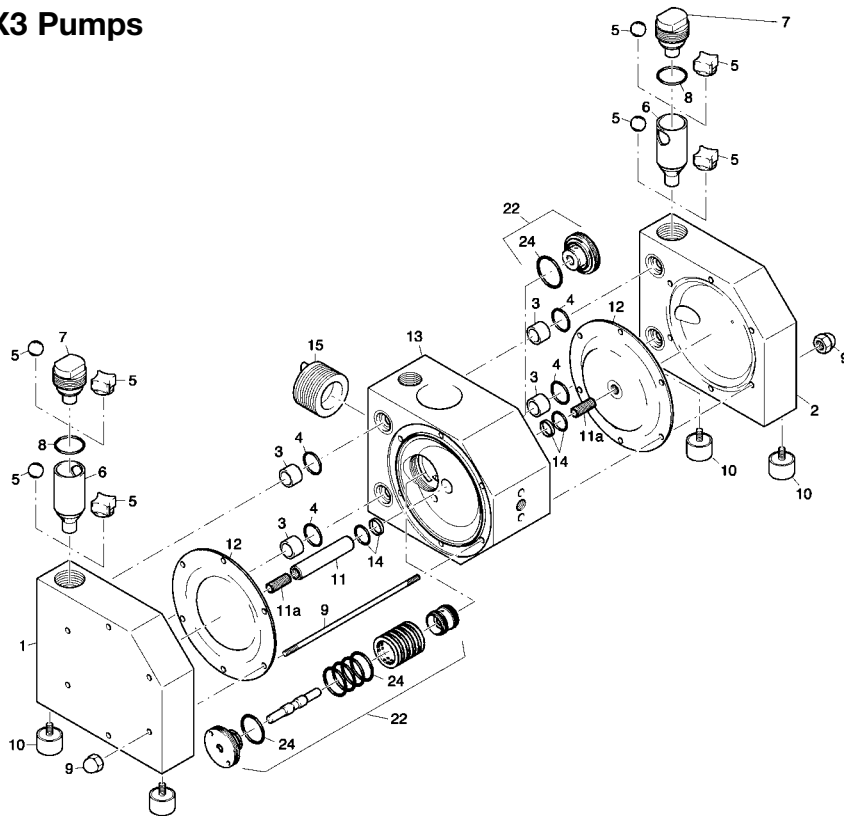

UNITEC™ UX SERIES PUMPS – RUBBER/TEFLON®-FITTED

Pump Model			UX.038	UX.050	UX.075	UX3
Item	Description	Qty.	P/N	P/N	P/N	P/N
1	Chamber, Liquid, Right	1	U4-10-310-55	U4-15-310-55	U4-20-310-55	U4-32-310-55
2	Chamber, Liquid, Left	1	U4-10-311-55	U4-15-311-55	U4-20-311-55	U4-32-311-55
3	Sleeve	4	U4-10-312-55	U4-15-312-55	U4-20-312-55	U4-32-312-55
4	o-ring, sleeve, ND	4	U9-12-619-72	U9-14-617-72	U9-20-502-72	U9-33-526-72
	o-ring, sleeve, TV	4	U9-12-619-59	U9-14-617-59	U9-20-552-59	U9-33-553-59
5	Valve Ball, ND	4	U1-10-032-72	U4-15-032-72	U1-15-032-72	U1-25-032-72
	Valve Ball, SS	4	U1-10-032-22	U4-15-032-22	U1-15-032-22	U1-25-032-22
	Valve Ball, TF	4	U1-10-032-60	U4-15-032-60	U1-15-032-60	U1-25-032-60
	Valve, Cylinder, PE	4	U4-10-313-52	U4-15-313-52	U4-20-313-52	U4-32-313-52
6	Valve Housing	2	U4-10-314-55	U4-15-314-55	U4-20-314-55	U4-32-314-55
7	Retainer, Top Valve	2	U4-10-317-55	U4-15-317-55	U4-20-317-55	U4-32-317-55
8	o-ring, top retainer, ND	2	U9-16-623-72	U9-20-602-72	U9-25-610-72	U9-40-613-72
	o-ring, top retainer, TV	2	U9-16-623-59	U9-20-602-59	U9-25-610-59	U9-40-613-59
9	Tie Rod, Housing	*	U4-10-020-22	U4-15-020-22	U4-20-020-22	U4-32-020-22
10	Foot, Pump Base	4	U1-08-022-85	U4-15-022-85	U4-15-022-85	U4-15-022-85
11	Shaft, Unitec	1	U2-08-030-22**	U2-08-030-22**	U2-15-030-22	U2-25-030-22
11a	Screw, Set, Shaft Unitec	2	-	-	U9-10-220-22	U9-12-221-22
12	Diaphragm, EX	2	-	U1-10-031-72	U1-15-031-72	U1-25-031-72
	Diaphragm, ET	2	U1-08-031-67	U1-10-031-67	U1-15-031-67	U1-25-031-67
13	Center housing	1	U4-10-340-55	U4-15-340-55	U4-20-340-55	U4-32-340-55
14	Piston Ring, Shaft	2	-	-	U1-15-041-64	U1-25-041-64
15	Muffler, Complete	1	U4-15-044-51	U4-15-044-51	U4-20-044-51	U4-20-044-51
22	Uni-Flo™ Air Valve Assembly	1	U2-08-001-84	U2-08-001-84	U2-15-001-84	U2-15-001-84
24	o-ring, air valve housing	6	U9-26-519-71**	U9-26-519-71**	U9-36-504-71**	U9-36-504-71**

* U.038 & U.050: 4 pieces; U.075 & U3: 6 pieces

** included in item 22



WARRANTY

Each and every product manufactured by Wilden Pump and Engineering, LLC is built to meet the highest standards of quality. Every pump is functionally tested to insure integrity of operation.

Wilden Pump and Engineering, LLC warrants that pumps, accessories and parts manufactured or supplied by it to be free from defects in material and workmanship for a period of one year from date of startup or two years from date of shipment, whichever comes first. Failure due to normal wear, misapplication, or abuse is, of course, excluded from this warranty.

Since the use of Wilden pumps and parts is beyond our control, we cannot guarantee the suitability of any pump or part for a particular application and Wilden Pump and Engineering, LLC shall not be liable for any consequential damage or expense arising from the use or misuse of its products on any application. Responsibility is limited solely to replacement or repair of defective Wilden pumps and parts.

All decisions as to the cause of failure are the sole determination of Wilden Pump and Engineering, LLC.

Prior approval must be obtained from Wilden for return of any items for warranty consideration and must be accompanied by the appropriate MSDS for the product(s) involved. A Return Goods Tag, obtained from an authorized Wilden distributor, must be included with the items which must be shipped freight prepaid.

The foregoing warranty is exclusive and in lieu of all other warranties expressed or implied (whether written or oral) including all implied warranties of merchantability and fitness for any particular purpose. No distributor or other person is authorized to assume any liability or obligation for Wilden Pump and Engineering, LLC other than expressly provided herein.

PLEASE PRINT OR TYPE AND FAX TO WILDEN

Item # _____ Serial # _____

Company Purchased From _____

Your Company Name _____

Industry _____

Your Name _____ Title _____

Your Address (Street) _____

(City) _____ (State) _____ (Postal Code) _____ (Country) _____

(Telephone) _____ (Fax) _____ (e-mail) _____

Number of pumps in facility? _____ Diaphragm _____ Centrifugal

_____ Gear _____ Submersible _____ Lobe _____ Other _____

Chemical(s) being pumped _____

How did you hear of Wilden Pump? _____ Trade Journal _____ Trade Show

_____ Internet/E-mail _____ Distributor _____ Other _____

ONCE COMPLETE, FAX TO (909) 783-3440

NOTE: WARRANTY VOID IF PAGE IS NOT FAXED TO WILDEN