

UNITEC™
SERIES

UU Series

Engineering Operation & Maintenance

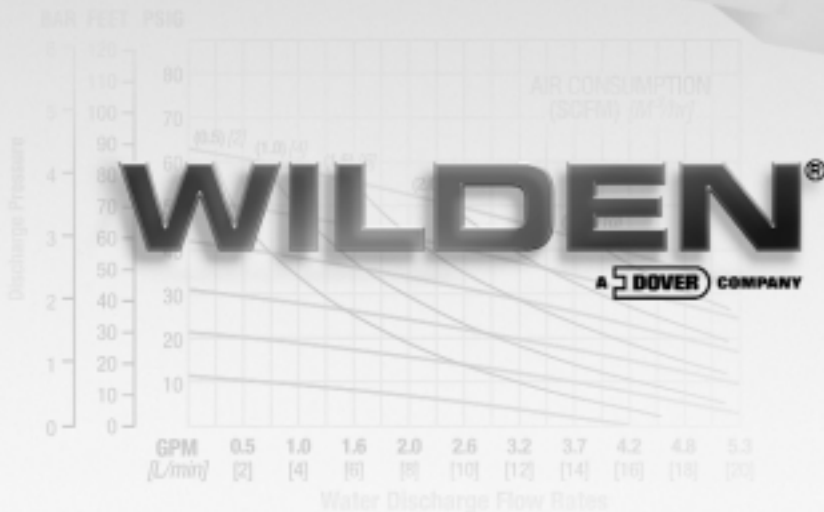
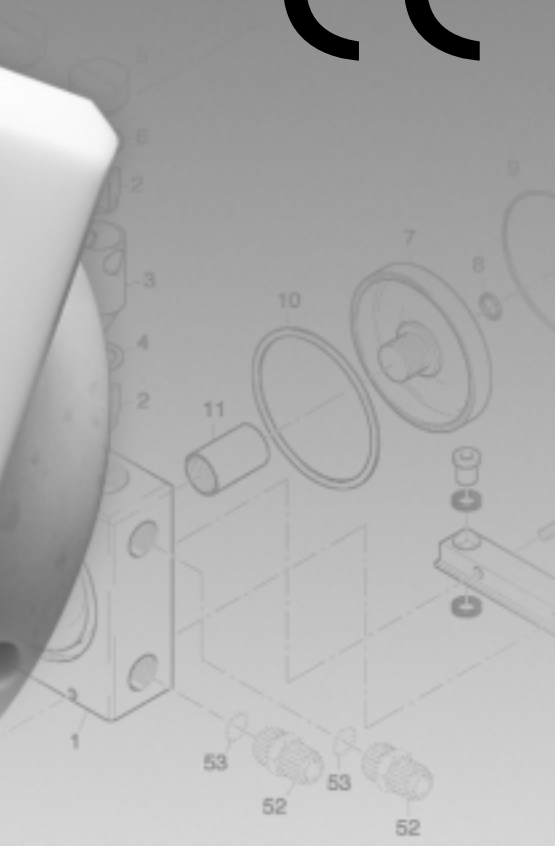
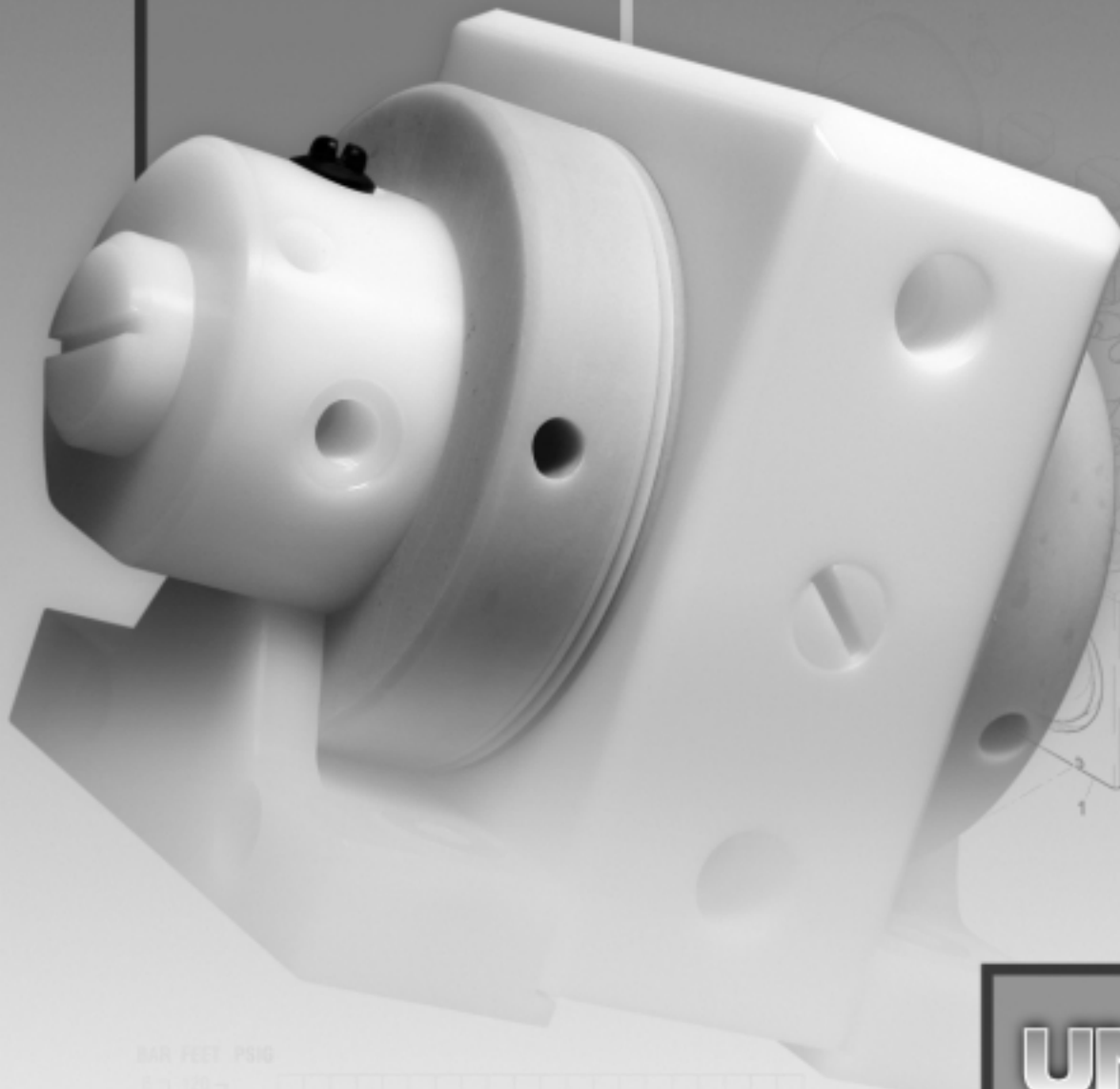

UNI-FLO™
PROGRESSIVE PUMP TECHNOLOGY

*Plastic
Pumps*

TT4500

EOM UNITEC UUP 8/04
REPLACES EOM UNITEC UU 6/03

TABLE OF CONTENTS

	PAGE #
SECTION 1 – PUMP DESIGNATION SYSTEM	1
SECTION 2 – HOW IT WORKS (PUMP & AIR SYSTEM)	2
SECTION 3 – CAUTIONS – READ FIRST!	3
SECTION 4 – DIMENSIONAL DRAWING	4
SECTION 5 – PERFORMANCE CURVES	
A. Model UU.038 Plastic/Teflon®-Fitted	5
B. Model UU.050 Plastic/Teflon®-Fitted	5
C. Model UU2 Plastic/Teflon®-Fitted	6
D. Model UU3 Plastic/Teflon®-Fitted	6
E. Model UU4 Plastic/Teflon®-Fitted	7
SECTION 6 – INSTALLATION & OPERATION	
A. Installation.....	8
B. Operation & Maintenance.....	8
C. Troubleshooting	9
SECTION 7 – DIRECTIONS FOR DISASSEMBLY/REASSEMBLY	
A. UNITEC™ UU Plastic Pumps.....	10
B. Reassembly Hints & Tips.....	13
SECTION 8 – OPTIONAL EQUIPMENT	
A. Integral Pulsation Dampeners	14
SECTION 9 – EXPLODED VIEW/PARTS LISTING	
A. UNITEC™ UU Series Plastic Pumps.....	16

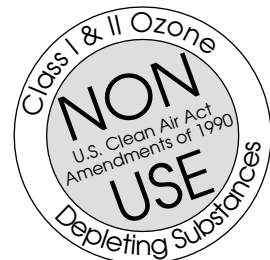

SECTION 1

WILDEN PUMP DESIGNATION SYSTEM

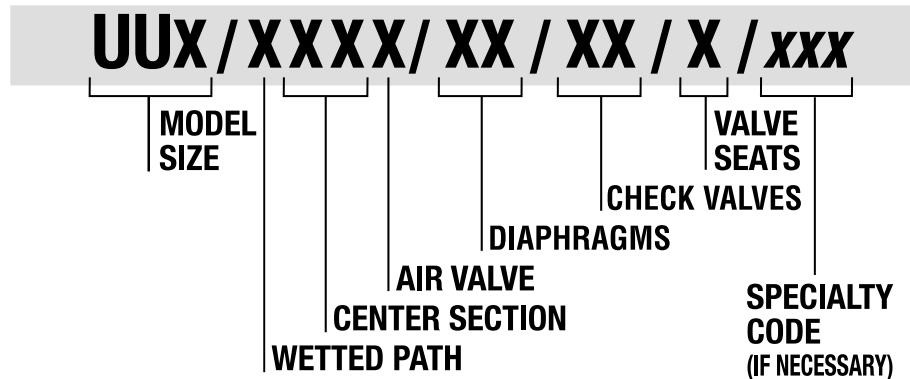

UNITEC™ UU SERIES PLASTIC PUMP MATERIAL CODES

MODEL SIZE

UU.038 = 10 mm (3/8")
 UU.050 = 13 mm (1/2")
 UU2 = 25 mm (1")
 UU3 = 32 mm (1 1/4")
 UU4 = 38 mm (1 1/2")

WETTED PATH

T = TEFLON® PTFE
 E = POLYETHYLENE

CENTER SECTION

TT = TEFLON® PTFE
 EE = POLYETHYLENE

AIR VALVE

E = POLYETHYLENE

DIAPHRAGMS

TX = TEFLON® PTFE
 W/INTEGRAL OUTER
 PISTON
 PX = POLYETHYLENE W/
 INTEGRAL OUTER PISTON

CHECK VALVES

CE = POLYETHYLENE-CYLINDER
 CT = TEFLON® PTFE-CYLINDER

VALVE SEATS

T = TEFLON® PTFE
 E = POLYETHYLENE

SPECIALTY CODES

640 = Flaretek® Connections
 812 = Stroke sensor
 816 = Diaphragm sensor
 818 = Stroke sensor, Flaretek®
 819 = Diaphragm sensor, Flaretek®
 820 = Diaphragm sensor, 3-wire
 821 = Diaphragm sensor, 3-wire, Flaretek®
 822 = Diaphragm sensor, 3-wire, w/plug
 (not available with UU3)
 823 = Diaphragm sensor, 3-wire w/plug
 (not available with UU3), Flaretek®
 824 = VCR Connectors for UU 316L SS

870 = Dampener, UU Teflon/Poly/Teflon
 871 = Dampener, UU Teflon/Poly/Teflon, Flaretek®
 872 = Dampener, UU Teflon/Teflon/Teflon
 873 = Dampener, UU Teflon/Teflon/Teflon, Flaretek®
 874 = Dampener, UU Teflon/Poly/Poly

SECTION 2

THE UNITEC™ UU PUMP — HOW IT WORKS

The Wilden Uni-Flo™ pump is an air-operated, positive displacement, self-primed pump. These drawings show the flow pattern through the pump upon its initial stroke. It is assumed the pump has no fluid in it prior to its initial stroke.

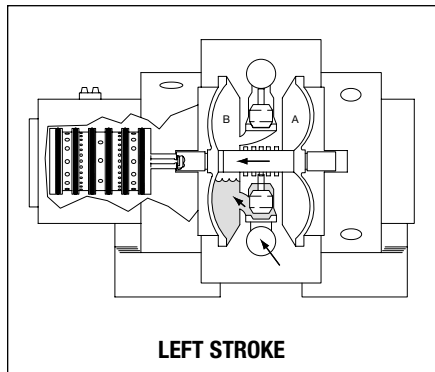

LEFT STROKE

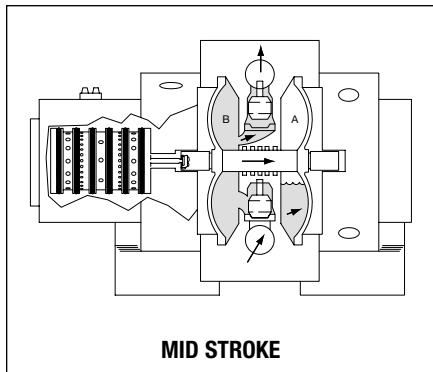

MID STROKE

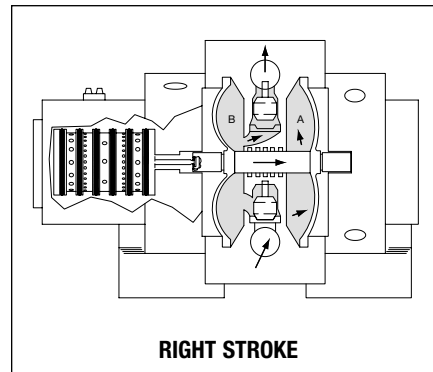

RIGHT STROKE

FIGURE 1: The air valve directs pressurized air to the outside of diaphragm A. The compressed air is applied directly to the liquid column separated by elastomeric diaphragms. The diaphragm acts as a separation membrane between the compressed air and liquid, balancing the load and removing mechanical stress from the diaphragm. The compressed air moves the diaphragm away from the air housing of the pump. The opposite diaphragm is pushed by the shaft connected to the pressurized diaphragm. Diaphragm B is on its suction stroke; air behind the diaphragm has been forced out to the atmosphere through the exhaust port of the pump. The movement of diaphragm B away from the center block of the pump creates a vacuum within chamber B. Atmospheric pressure forces fluid into the inlet manifold forcing the inlet check valve off its seat. Liquid is free to move past the inlet check valve and fill the liquid chamber (see shaded area).

FIGURE 2: When the pressurized diaphragm, diaphragm A, reaches the limit of its discharge stroke, the air valve redirects pressurized air to the outside of diaphragm B. The pressurized air forces diaphragm B away from the air housing while pushing diaphragm A away from the center block. Diaphragm B is now on its discharge stroke. Diaphragm B forces the inlet check valve onto its seat due to the hydraulic forces developed in the liquid chamber and manifold of the pump. These same hydraulic forces lift the discharge check valve off its seat, while the opposite discharge check valve (not visible) is forced onto its seat, forcing fluid to flow through the pump discharge. The movement of diaphragm A toward the center block of the pump creates a vacuum within liquid chamber A. Atmospheric pressure forces fluid into the inlet manifold of the pump. The inlet check valve (not visible) is forced off its seat allowing the fluid being pumped to fill the liquid chamber.

FIGURE 3: At completion of the stroke, the air valve again redirects air to the outside of diaphragm A, which starts diaphragm B on its exhaust stroke. As the pump reaches its original starting point, each diaphragm has gone through one exhaust and one discharge stroke. This constitutes one complete pumping cycle. The pump may take several cycles to completely prime depending on the conditions of the application.

THE UNI-FLO™ AIR SYSTEM — HOW IT WORKS

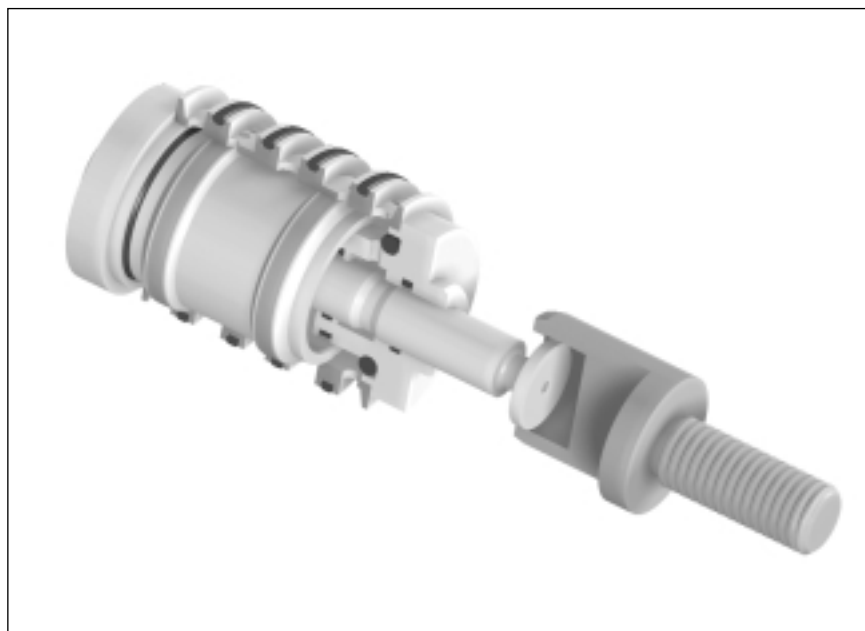

The Uni-Flo™ air distribution system, the driving force behind UNITEC™ pumps, is located on one side of the pump, outside the center section. The Uni-Flo™ system uses a main air valve body and mechanically actuated pilot spool mechanism to direct inlet air pressure alternately behind each diaphragm while at the same time exhausting the air behind the opposite diaphragm to atmosphere. Air inlet pressure has a direct relation to the fluid discharge pressure that the pump can develop (head), while the volume of air has a direct relation to how quickly the pump will reciprocate (flow).

The pilot spool is pushed alternately left and right as the diaphragms move. This movement is the result of the pilot spool being connected to one diaphragm which in turn is connected to the second diaphragm via the main shaft. The movement of the pilot spool from one side to the other changes the inlet and exhaust porting to each diaphragm by reversing the air flow behind each diaphragm.

This inherently safe design needs no electronic sensors or switches to operate reliably while delivering product. Speed and flow can be controlled with simple adjustments to the air regulator, air inlet valve or fluid system valves. The Uni-Flo™ system operates solely on compressed air and is simple to use, specify and operate.

SECTION 3**WILDEN UNITEC™ PLASTIC PUMPS
CAUTIONS – READ FIRST!**

CAUTION: This pump is designed to run only on clean-dry air at all times. If oil and water may migrate into pump from air supply, a desiccant dryer must be installed.



CAUTION: Do not lubricate air supply — lubrication will reduce pump performance.

**TEMPERATURE LIMITS:**

Polyethylene	0.0°C to 70.0°C	32°F to 158°F
Teflon® PTFE	4.4°C to 120°C	40°F to 248°F



NOTE: Conductive and unfilled plastics have the same temperature range and chemical resistance.



CAUTION: When choosing pump materials, be sure to check the temperature limits for all wetted components. Example: Nordel® has a maximum limit of 137.8°C (280°F) but polyethylene has a maximum limit of only 70.0°C (158°F).



CAUTION: Maximum temperature limits are based upon mechanical stress only. Certain chemicals will significantly reduce maximum safe operating temperatures. Consult Wilden Chem Guide (E-04) for chemical compatibility and temperature limits.



CAUTION: Always wear safety glasses and appropriate protection when operating pump. If diaphragm rupture occurs, material being pumped may be forced out air exhaust.



WARNING: Prevention of static sparking — If static sparking occurs, fire or explosion could result. As each application has different requirements, please consult the local, regional or government regulatory agency for details on proper grounding for the application.



CAUTION: Do not exceed 6 bar (87 psig) air supply pressure.



CAUTION: Before any maintenance or repair is attempted, the compressed air line to the pump should be disconnected and all air pressure allowed to bleed from pump. Before disassembly of the pump, or removal from process lines, all pressure must also be bled from the liquid side of the pump and all fluid drained into a suitable container. Failure to do so may result in product under pressure being sprayed from system.



CAUTION: Blow out air line for 10 to 20 seconds before attaching to pump to make sure all pipeline debris is clear. A 5µ (micron) in-line air filter is recommended.



CAUTION: The UU Series pumps are not submersible. If your application requires your pump to be submersed, contact the factory for details on a different Wilden pump model.



CAUTION: Pumps should be flushed thoroughly with water before installation into process line.



CAUTION: Long-term exposure to UV rays may damage unfilled polyethylene. If located outside an unfilled polyethylene pump should be protected from UV rays.



CAUTION: Use caution not to overtighten air and liquid pipe connections, or pump fasteners. Overtorque of fittings or fasteners may damage the pump or cause leaking of process fluid.

SECTION 4

DIMENSIONAL DRAWING WILDEN UNITEC™ UU PLASTIC MODELS

DIMENSIONS FOR PLASTIC UU SERIES PUMPS

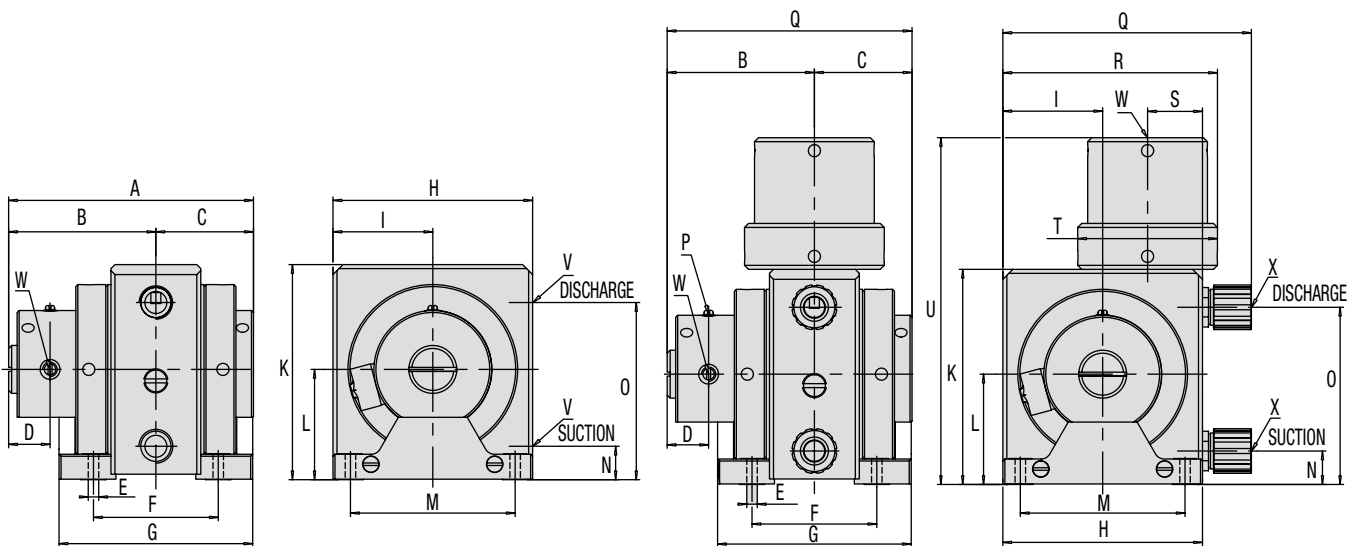

	UU.038	UU.050	UU2	UU3	UU4
A	185 mm (7.28")	201 mm (7.91")	246 mm (9.69")	303 mm (11.93")	374 mm (14.72")
B	112 mm (4.41")	119 mm (4.69")	148 mm (5.83")	184 mm (7.24")	215 mm (8.46")
C	73 mm (2.87")	82 mm (3.23")	98 mm (3.86")	119 mm (4.69")	159 mm (6.26")
D	35.5 mm (1.40")	35.5 mm (1.40")	41.5 mm (1.63")	51 mm (2.01")	51 mm (2.01")
E	10.5 mm (0.41")	10.5 mm (0.41")	10.5 mm (0.41")	10.5 mm (0.41")	10.5 mm (0.41")
F	93 mm (3.66")	105 mm (4.13")	125 mm (4.92")	149 mm (5.87")	227 mm (8.94")
G	143 mm (5.63")	160 mm (6.30")	194 mm (7.64")	236 mm (9.29")	314 mm (12.36")
H	114 mm (4.49")	150 mm (5.91")	200 mm (7.87")	260 mm (10.24")	330 mm (12.99")
I	57 mm (2.24")	75 mm (2.95")	100 mm (3.94")	130 mm (5.12")	165 mm (6.50")
K	131 mm (5.16")	168 mm (6.61")	216 mm (8.50")	266 mm (10.47")	346 mm (13.62")
L	72 mm (2.83")	88 mm (3.46")	111 mm (4.37")	136 mm (5.35")	181 mm (7.13")
M	79 mm (3.11")	115 mm (4.53")	165 mm (6.50")	225 mm (8.86")	290 mm (11.42")
N	35 mm (1.38")	33 mm (1.30")	34 mm (1.34")	39 mm (1.54")	61 mm (2.40")
O	104 mm (4.09")	140 mm (5.51")	178 mm (7.01")	223 mm (8.78")	281 mm (11.06")
P	1/4" NPT	1/4" NPT	1/4" NPT	1/4" NPT	1/4" NPT
Q	155 mm (6.10")	196 mm (7.72")	251 mm (9.88")	313 mm (12.32")	N/A
R	136 mm (5.35")	161 mm (6.34")	215 mm (8.46")	286 mm (11.26")	345 mm (13.58")
S	33 mm (1.30")	44 mm (1.73")	55 mm (2.17")	74 mm (2.91")	95 mm (3.74")
T	110 mm (4.33")	110 mm (4.33")	140 mm (5.51")	200 mm (7.87")	220 mm (8.66")
U	246 mm (9.69")	283 mm (11.14")	348 mm (13.70")	429 mm (16.89")	578 mm (22.76")
V	3/8" NPT	1/2" NPT	1" NPT	1-1/4" NPT	1-1/2" NPT
W	1/4" NPT	1/4" NPT	1/4" NPT	1/4" NPT	3/8" NPT
X (Flaretek)	1/2" Pipe-OD	3/4" Pipe-OD	1" Pipe-OD	1-1/4" Pipe-OD	N/A

SECTION 5A

PERFORMANCE CURVE UU.038 PLASTIC TEFLON®-FITTED

Height130 mm (5.1")
 Width185 mm (7.3")
 Depth114 mm (4.5")
 Ship Weight : PTFE/PE2.3 kg (5.1 lbs)
 PTFE/PTFE2.6 kg (5.7 lbs)
 Air Inlet6 mm (¼")
 Inlet10 mm (⅜")
 Flaretek® Discharge13 mm (½")
 Discharge10 mm (⅜")
 Flaretek® Inlet.....13 mm (½")
 Suction Lift1 m (3') Dry
 8 m (26') Wet
 Sound: Max. dBA72
 Displacement Per Stroke ..0.003 L (0.013 gal)
 Max. Flow Rate.....10 lpm (2.6 gpm)
 *Displacement per stroke was calculated at
 6.9 bar (100 psig) air inlet pressure against
 0 bar (0 psig) head pressure.

Example: To pump 4.5 lpm (1.2 gpm) against
 a discharge pressure head of 2.3 bar (34 psig)
 requires 2.7 bar (39 psig) and 3 Nm³/h
 (0.7 scfm) air consumption. (See dot on chart.)

Caution: Do not exceed 6 bar (87 psig)
 air inlet supply pressure.

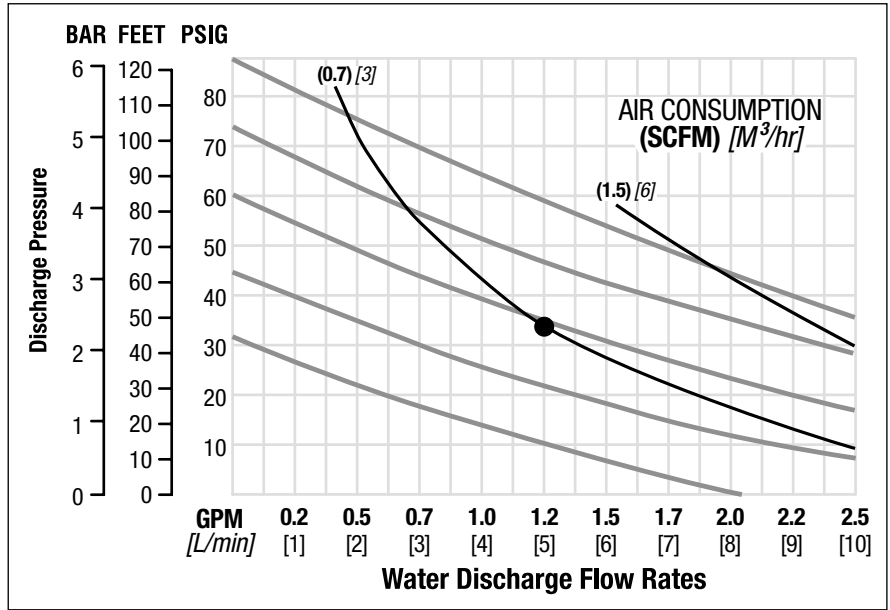

SECTION 5B

PERFORMANCE CURVE UU.050 PLASTIC TEFLON®-FITTED

Height167 mm (6.6")
 Width201 mm (7.9")
 Depth150 mm (5.9")
 Ship Weight : PTFE/PE4.2 kg (9.3 lbs)
 PTFE/PTFE5.0 kg (11.0 lbs)
 PE/PE2.8 kg (6.2 lbs)
 Air Inlet6 mm (¼")
 Inlet13 mm (½")
 Flaretek® Discharge19 mm (¾")
 Discharge13 mm (½")
 Flaretek® Inlet.....19 mm (¾")
 Suction Lift2.5 m (8') Dry
 9.0 m (30') Wet
 Sound: Max. dBA72
 Displacement Per Stroke ..0.009 L (0.034 gal)
 Max. Flow Rate.....20 lpm (5.3 gpm)
 *Displacement per stroke was calculated at
 6.9 bar (100 psig) air inlet pressure against
 0 bar (0 psig) head pressure.

Example: To pump 12.1 lpm (3.2 gpm)
 against a discharge pressure head of 2.8 bar
 (40 psig) requires 4.0 bar (58 psig) and
 6 Nm³/h (1.6 scfm) air consumption. (See dot
 on chart.)

Caution: Do not exceed 6 bar (87 psig)
 air inlet supply pressure.

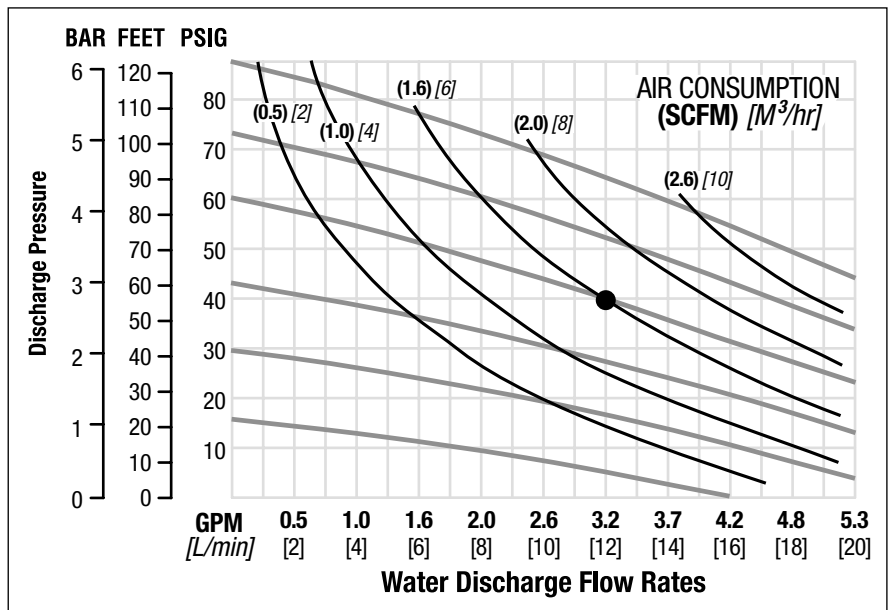

SECTION 5C

PERFORMANCE CURVE UU2 PLASTIC TEFLON®-FITTED

Height222 mm (8.7")
 Width246 mm (9.7")
 Depth200 mm (7.9")
 Ship Weight : PTFE/PE8.8 kg (19.4 lbs)
 PE/PE5.8 kg (12.8 lbs)
 Air Inlet6 mm (¼")
 Inlet.....25 mm (1")
 Discharge25 mm (1")
 Suction Lift3.5 m (11.5') Dry
 9 m (30') Wet

Sound: Max. dBA72
 Displacement Per Stroke ..0.029 L (0.110 gal)
 Max. Flow Rate50 lpm (13 gpm)
 *Displacement per stroke was calculated at 6.9 bar (100 psig) air inlet pressure against 0 bar (0 psig) head pressure.

Example: To pump 22.7 lpm (6 gpm) against a discharge pressure head of 3 bar (44 psig) requires 3.4 bar (50 psig) and 15 Nm³/h (4 scfm) air consumption. (See dot on chart.)

Caution: Do not exceed 6 bar (87 psig) air inlet supply pressure.

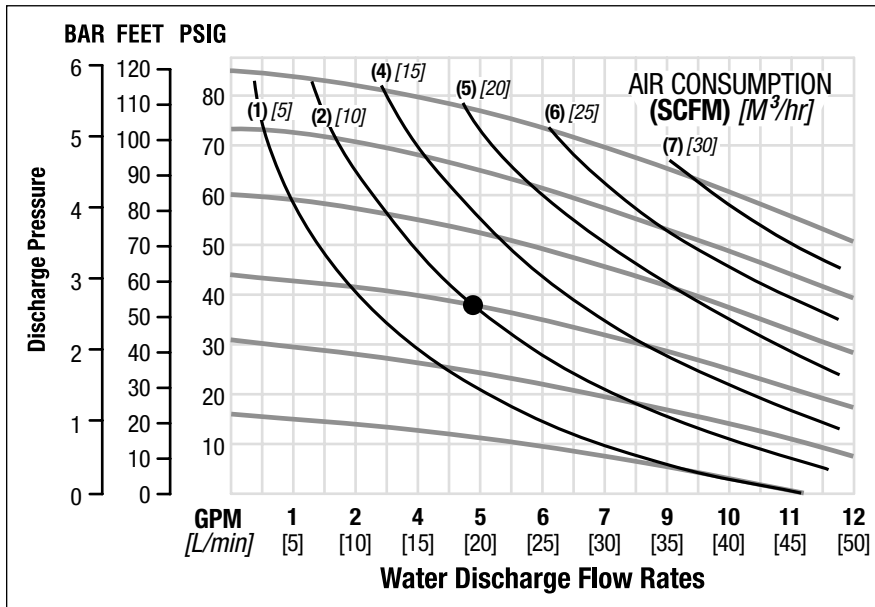

SECTION 5D

PERFORMANCE CURVE UU3 PLASTIC TEFLON®-FITTED

Height265 mm (10.4")
 Width303 mm (11.9")
 Depth260 mm (10.2")
 Ship Weight : PTFE/PE17.6 kg (38.8 lbs)
 PE/PE11.8 kg (26.0 lbs)
 Air Inlet6 mm (¼")
 Inlet32 mm (1 ¼")
 Discharge32 mm (1 ¼")
 Suction Lift4 m (13') Dry
 9 m (30') Wet

Sound: Max. dBA72
 Displacement Per Stroke ..0.066 L (0.250 gal)
 Max. Flow Rate100 lpm (26 gpm)
 *Displacement per stroke was calculated at 6.9 bar (100 psig) air inlet pressure against 0 bar (0 psig) head pressure.

Example: To pump 38 lpm (10 gpm) against a discharge pressure head of 3.3 bar (48 psig) requires 4.1 bar (60 psig) and 20 Nm³/h (5 scfm) air consumption. (See dot on chart.)

Caution: Do not exceed 6 bar (87 psig) air inlet supply pressure.

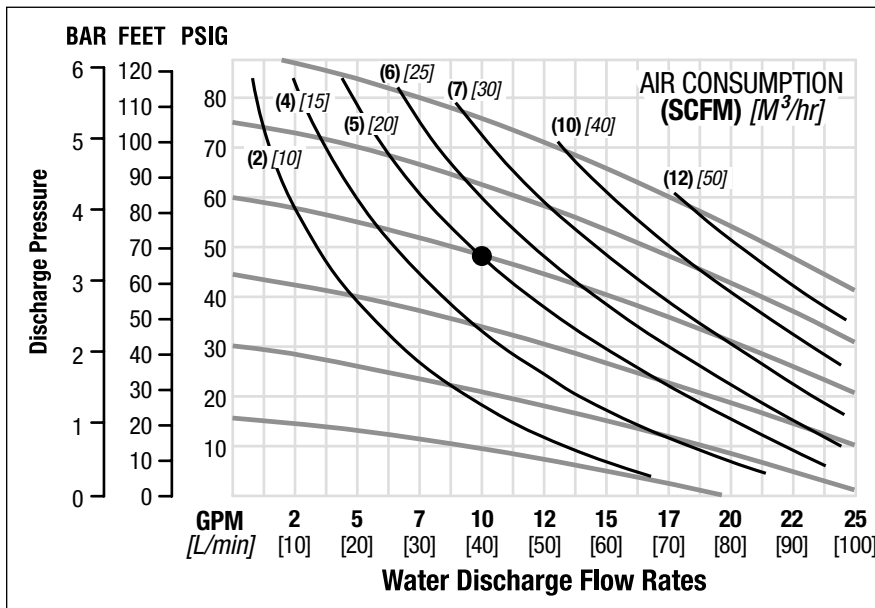

SECTION 6B

SUGGESTED INSTALLATION

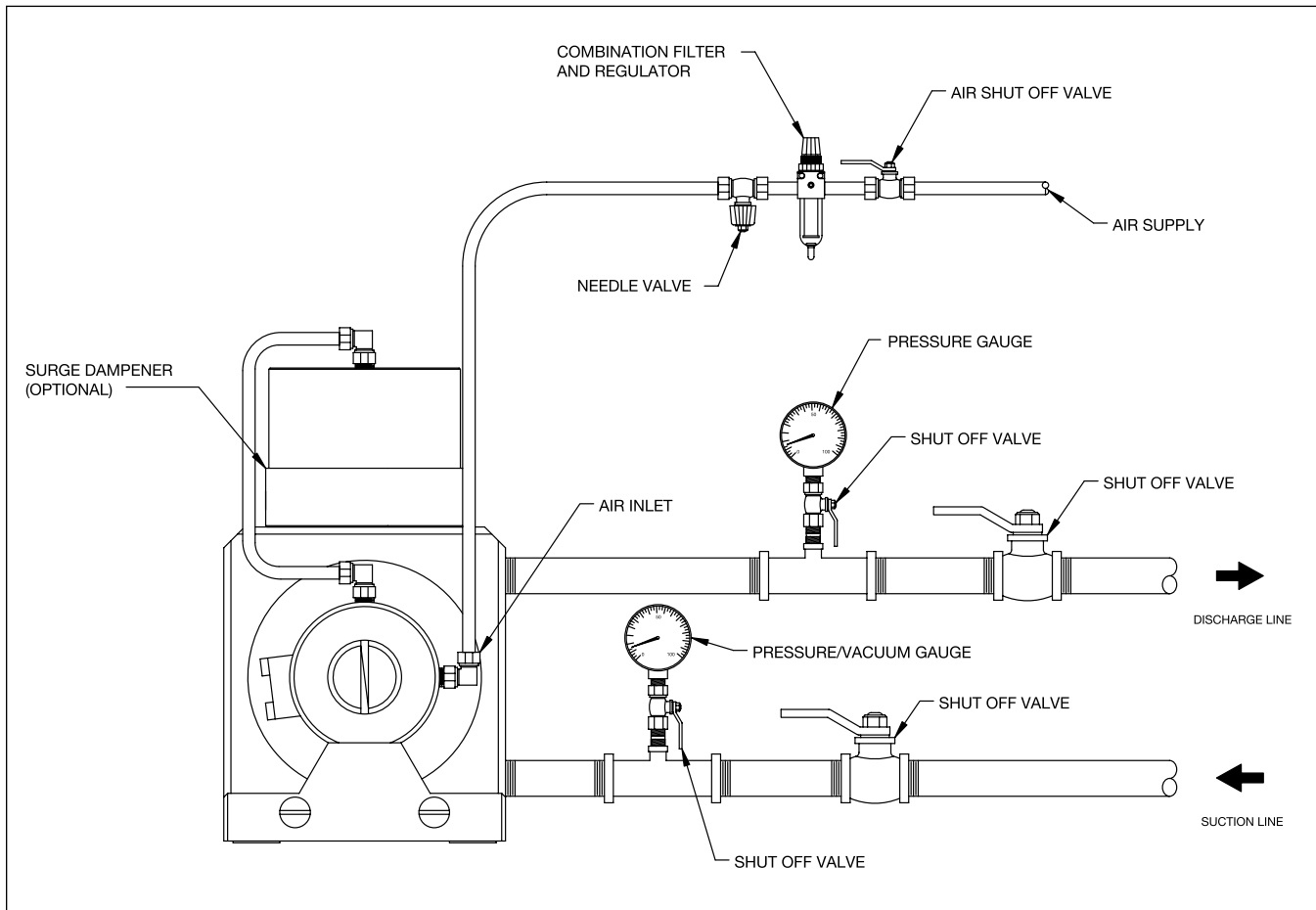

SECTION 6B

SUGGESTED OPERATION AND MAINTENANCE INSTRUCTIONS

OPERATION: UU pumps do not require in-line lubrication. Lubrication will damage the pump! If the pump is lubricated by an external source, the pump's internal seals may be damaged causing premature failure of the pump.

Pump discharge rate can be controlled by limiting the volume and/or pressure of the air supply to the pump (preferred method). An air regulator is used to regulate air pressure. A needle valve is used to regulate volume. Pump discharge rate can also be controlled by throttling the pump discharge by partially closing a valve in the discharge line of the pump. This action increases friction loss which reduces flow rate. This is useful when the need exists to control the pump from a remote location. When the pump discharge pressure equals or exceeds the air supply pressure, the pump will stop; no bypass or pressure relief valve is needed, and pump damage will not occur. The pump has reached a "deadhead" situation and can be restarted by reducing the fluid discharge pressure or increasing the air inlet pressure. The Wilden UU pump runs solely on clean, dry air and generates little heat, therefore your process fluid temperature will not be affected.

MAINTENANCE AND INSPECTIONS: Since each application is unique, maintenance schedules may be different for every pump. Frequency of use, line pressure, viscosity and abrasiveness of process fluid all affect the parts life of a Wilden pump. Periodic inspections have been found to offer the best means for preventing unscheduled pump downtime. Personnel familiar with the pump's construction and service should be informed of any abnormalities that are detected during operation. Read all cautions before performing any service on a Wilden pump.

RECORDS: When service is required, a record should be made of all necessary repairs and replacements. Over a period of time, such records can become a valuable tool for predicting and preventing future maintenance problems and unscheduled downtime. In addition, accurate records make it possible to identify pumps that are poorly suited to their applications.

SECTION 6C

TROUBLESHOOTING

Pump will not run or runs slowly.

1. Ensure that the air inlet pressure is at least 0.4 bar (5 psig) above startup pressure and that the differential pressure (the difference between air inlet and liquid discharge pressures) is not less than 0.7 bar (10 psig).
2. Check air inlet filter for debris (see recommended installation). A 5 μ (micron) air filter must be installed in the air inlet line of the pump to prevent air line particulate from entering and damaging air system.
3. Check for extreme air leakage (blow by) which would indicate worn seals/bores in the air valve, pilot spool and main shaft.
4. Disassemble pump and check for obstructions in the air passageways or objects which would obstruct the movement of internal parts.
5. Check for sticking ball check valves. If material being pumped is not compatible with pump elastomers, swelling may occur. Replace ball check valves and seals with proper elastomers. Also, as the check valve balls wear out, they become smaller and can become stuck in the seats. In this case, replace balls and seats.
6. Diaphragms may have a pinhole allowing air to escape to the liquid side of the pump reducing performance. Check and replace diaphragms as necessary.
7. Air valve may have debris from inlet air system. A 5 μ (micron) air filter must be installed in the air inlet line of the pump to prevent air line particulate from entering and damaging air system.

Pump does not run.

1. Air supply line or discharge fluid line is blocked or a valve is closed. Check valves for system and ensure they are set as desired, or disassemble pump and check for blockage.
2. Muffler may be blocked with debris or other contaminants. This will prevent air from exhausting. Replace muffler.

Pump runs and then stops with no external visible reason.

1. Ice within the air system may be blocking a port. Check system for blockage and add a dryer in air inlet line to prevent moisture from entering air system.
2. System air pressure may have dropped below system requirements. This will not hurt the pump but will put the pump into a dead-head condition. The pump will restart once air supply pressure is increased or discharge head decreases below air inlet pressure.
3. Air system may have become blocked by debris. A 5 μ (micron) air filter must be installed in the air inlet line of the pump to prevent air line particulate from entering and damaging air system.
4. Air system may need maintenance. Disassemble pump and replace worn parts as necessary.
5. Diaphragm has ruptured and the product being pumped has flooded the air system stalling the pump. Disassemble the pump, clean air system of process fluid and replace diaphragms.
6. Air inlet line filter may be blocked with debris not allowing enough volume into pump for proper operation. Check and replace air inlet filter as necessary. A 5 μ (micron) air filter must be installed in the air inlet line of the pump to prevent air line particulate from entering and damaging air system.

Pump runs but discharge flow decreases over time.

1. Ice within the air system may be reducing air flow in the pump. Check system for blockage and add a dryer in air inlet line to prevent moisture from entering air system.
2. Check air inlet line pressure to confirm a pressure drop has not occurred. If air pressure has decreased, locate the source of the air pressure loss and correct.

3. Debris from the air inlet line may have migrated into air system prematurely wearing the seals. Disassemble pump and replace parts as necessary. A 5 μ (micron) air filter must be installed in the air inlet line of the pump to prevent air line particulate from entering and damaging air system.

Product comes out air exhaust.

1. Check for diaphragm rupture.

Pump runs but little or no product flows.

1. Check for pump cavitation; slow pump speed down to allow thick material to flow into the liquid chambers.
2. Verify that vacuum required to lift liquid is not greater than the vapor pressure of the material being pumped (cavitation).
3. Check for sticking ball check valves. If material being pumped is not compatible with pump elastomers, swelling may occur. Replace ball check valves and seals with proper elastomers. Also, as the check valve balls wear out, they become smaller and can become stuck in the seats. In this case, replace balls and seats.
4. Pump may be operating too fast. Often to prime the pump, especially when at the maximum capability of the pump with the system design, you must lower the air inlet pressure to achieve maximum suction lift. Once primed, line pressure can be raised to meet system requirements.
5. Abrasives in the product have deteriorated the valve ball or check valve and a good seal against the valve seat is no longer being achieved. Disassemble pump and replace worn parts as necessary.
6. Ensure a vacuum is not present inside the source fluid container. Check that the tank/tote vent is open and air is allowed into the tank/tote as product is being removed.
7. Check suction line for leaks and tight connections. In the event a union is loose the pump will be unable to pull the product efficiently into the pump. Tighten any loose suction line connections.
8. Check EOM for details on suction capabilities and ensure the system design is within the suction capabilities of the pump.

Pump air valve freezes.

1. Condensation from the air line is most likely bypassing the desiccant dryer or the dryer is beyond its useful life. Replace/service dryer.
2. No dryer is installed ahead of pump, allowing moisture into air system. This will damage air system and may render it inoperable. Install a desiccant dryer on the air inlet line with a 5 μ (micron) air filter.

Air bubbles in pump discharge.

1. Check for ruptured diaphragm.
2. Check tightness of housing bolts and integrity of O-rings and seals, especially at intake manifold.
3. Ensure pipe connections are airtight.

Pump leaks between center section and liquid chambers.

1. Tighten all tie rods on pump to ensure a tight fit with the center section.
2. The O-rings on the sleeves between the liquid chambers and center section may be damaged. Disassemble pump and check O-rings for damage and replace as necessary.
3. Diaphragms and/or O-rings may have been damaged due to incompatibility with chemical being pumped. Check chemical use chart and select a material more appropriate for the process fluid.
4. Sleeves between center section and liquid chambers may be damaged during maintenance. Disassemble pump and replace worn or damaged parts as necessary.

SECTION 7A

UU PLASTIC DIRECTIONS FOR DISASSEMBLY/REASSEMBLY

CAUTION: Before any maintenance or repair is attempted, the compressed air line to the pump should be disconnected and all air pressure allowed to bleed from the pump. Use extreme caution as the pump liquid path may still be under pressure even though air line is disconnected. Disconnect all intake, discharge, and air lines. Drain the pump by turning it upside down and allowing any fluid to flow into a suitable container. Be aware of any hazardous effects of contact with your process fluid.

TOOLS REQUIRED:

Repair Tools from Wilden for UU Series
Medium Flat Head Screwdriver

NOTE: The model used for these instructions incorporates Teflon® diaphragms, valve checks, and seat O-rings.

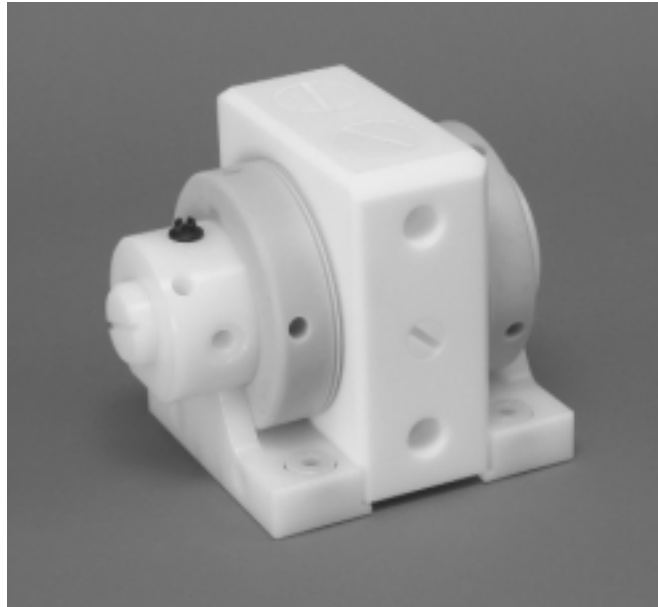

DISASSEMBLY:

Step 1.

Figure 1

Before disassembly, note orientation of center housing and all external fasteners. This will assist with proper reassembly and save time later.

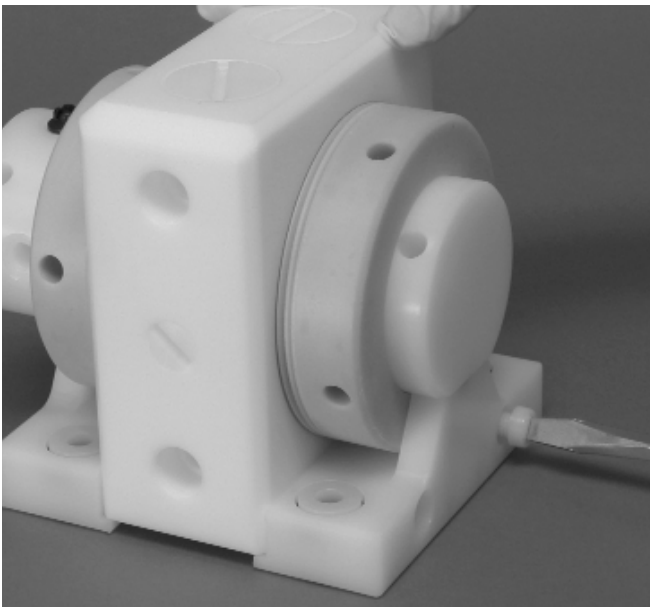

Step 2.

Figure 2

Using a medium size screwdriver, remove the side bolts from foot assembly by rotating counter-clockwise.

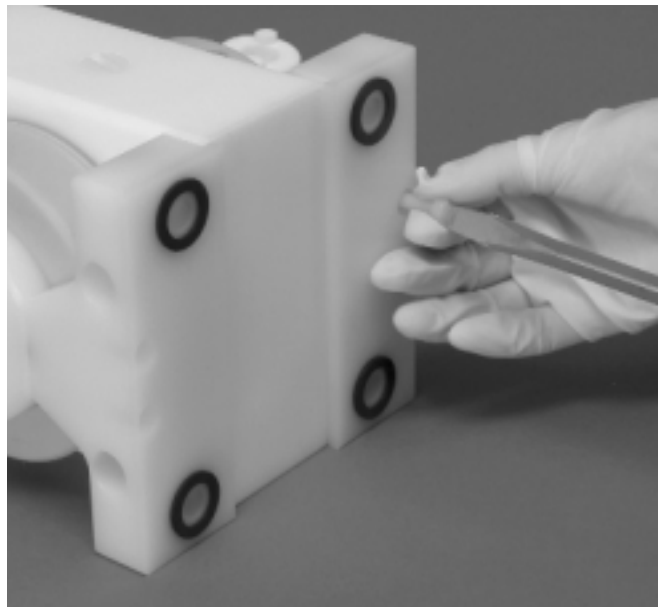

Step 3.

Figure 3

Using a medium size screwdriver, remove the bottom bolts from foot assembly by rotating counter-clockwise.

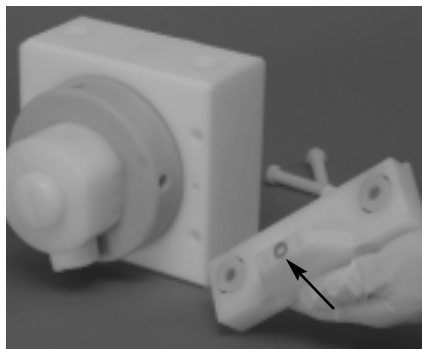

Step 4 *Figure 4*
Inspect air channel O-rings for damage or wear and replace as necessary.

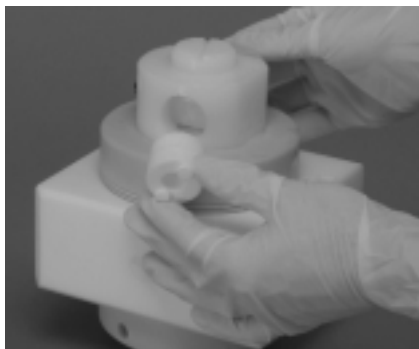

Step 5 *Figure 5*
Remove muffer from air valve by rotating counter-clockwise.

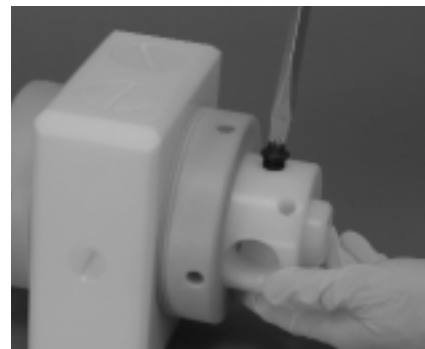

Step 6 *Figure 6*
Remove plug on top of air valve assembly with a medium screwdriver by rotating counter-clockwise.

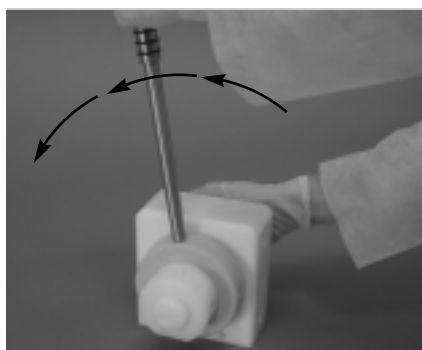

Step 7 *Figure 7*
Using disassembly tool, remove union ring on air valve side of pump. Insert small end of tool into pre-drilled holes and rotate counter-clockwise.

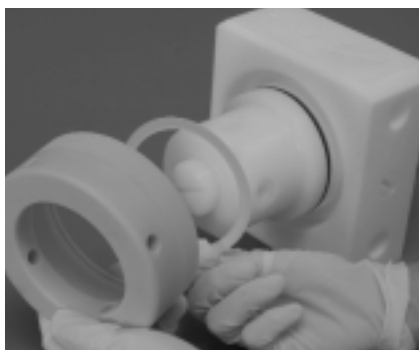

Step 8 *Figure 8*
Remove union ring and flat Teflon® gasket and replace as necessary.



Step 9 *Figure 9*
Remove union ring/side housing O-ring and inspect for damage or wear. Replace as necessary.

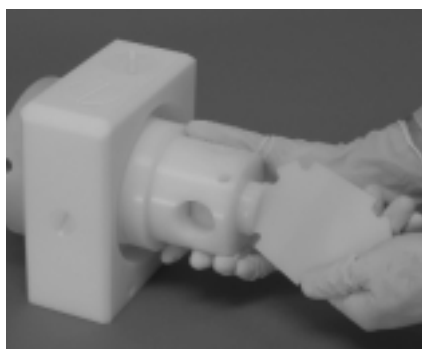

Step 10 *Figure 10*
Using plastic disassembly tool, remove air valve end cap by turning counter-clockwise.

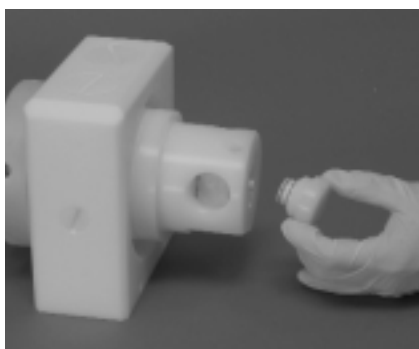

Step 11 *Figure 11*
After removal of end cap, inspect for damage, wear and debris. Replace as necessary with complete Uni-Flo™ air valve assembly.

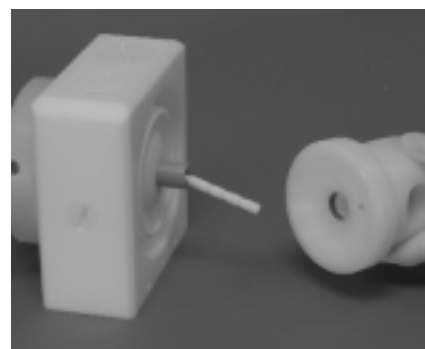

Step 12 *Figure 12*
Now remove side housing. Removal of air valve for complete inspection is now possible.

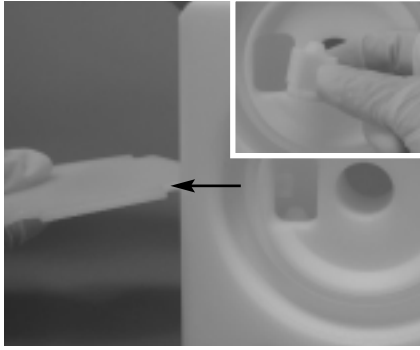

Step 22 *Figure 22*

Remove bottom check valve stops using disassembly tool. Rotate counter-clockwise. Once removed, pull bottom checks out through openings in center section as shown.

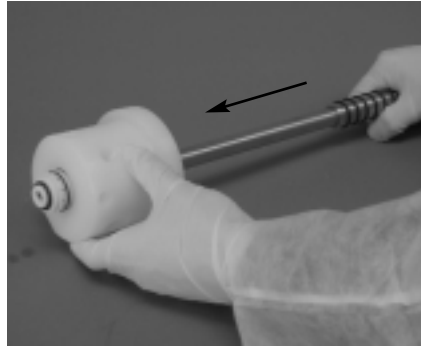

Step 23 *Figure 23*

To remove air valve assembly for complete inspection, gently push air valve assembly out of housing using the small end of the disassembly tool.



Step 24 *Figure 24*

Disassemble and inspect all air valve components for wear. Replace entire air valve assembly when wear is evident.

SECTION 7B

REASSEMBLY HINTS & TIPS

When reassembling a UU series pump, it is important to pay particular attention to specific details to avoid damaging the pump or limiting pump performance. To reassemble a UU pump follow disassembly instructions 1 through 24 in reverse order and be sure to adhere to the following assembly hints & tips.

1. Before installing or inserting any components, moisten all parts with distilled water for lubrication. DO NOT use any oil or silicone lubricants as these may damage the pump or render it inoperable.
2. When inserting air valve assembly into side housing and installing end cap, be sure to use the plastic tool included with the pump.
3. When installing valve stops into center section, be sure to tighten clockwise until the stop.
4. When reinstalling the diaphragms it is imperative to tighten them counter clockwise until they stop fully against the pump shaft.
5. When installing the cascade sleeves into the diaphragms, be sure to tighten counter clockwise until they bottom out on the diaphragm face.
6. URGENT NOTE: Be sure to install NEW diaphragm gaskets (PTFE) before any rebuild of the pump. Failure to install new gaskets will result in leaks past the diaphragm and into air system of pump.
7. URGENT NOTE: When installing the union rings of the pump around diaphragms, rotate clockwise until snug. WAIT TWO HOURS. Then continue rotating the union rings until the outside tolerance for your pump is achieved (see chart). This is to allow the diaphragm gasket (PTFE) to properly seal between the diaphragm and center housing.

Size	A-mm (in)
UU.038	28.8 (1.13)
UU.050	31.3 (1.23)
UU2	35.5 (1.40)
UU3	41.3 (1.63)

Tolerance +0.3 mm (+.012") / -0.5 (-.020")

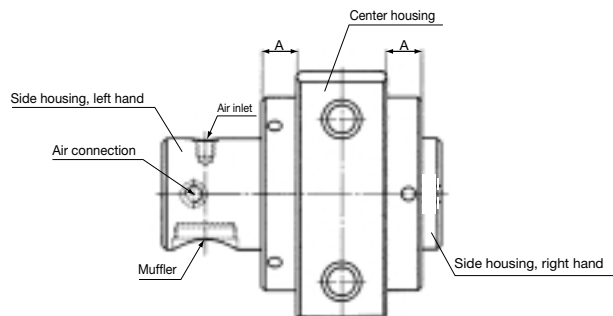

SECTION 8A

OPTIONAL EQUIPMENT FOR UU SERIES PLASTIC PUMPS

INTEGRAL PULSATION DAMPENERS

All UNITEC™ UU series pumps can be easily fitted with an integral pulsation dampener to minimize the effect of the pumps reciprocating action on the process system. Typical to all air-operated double-diaphragm pumps the reciprocating action of the diaphragms, coupled with the cross checking action of the check valves, causes a fluctuation in the discharge pressure while pumping. Each time a diaphragm reaches the end of its discharge stroke and begins to move back toward the center section the fluid stops for a fraction of a second while the opposite diaphragm is being pressurized in preparation for another discharge stroke. Once the opposite diaphragm is pressurized with supply air pressure, fluid on the opposite side of the pump is accelerated towards the discharge of the pump.

The integral dampeners combat this fluctuation in pressure by absorbing the pressure peaks as the pump reaches the full length of the stroke. The dampeners also fill the pressure valleys between strokes by forcing accumulated process fluid back into the process line as the pump is changing direction to begin discharging fluid from the opposite chamber. The dampeners are designed to attach directly to the center section of a UU series pump, with no additional hardware or piping required.

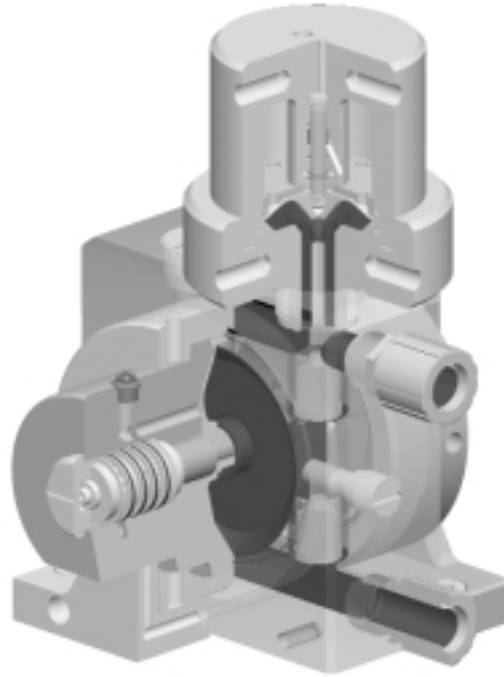

SECTION 9A

EXPLODED VIEW

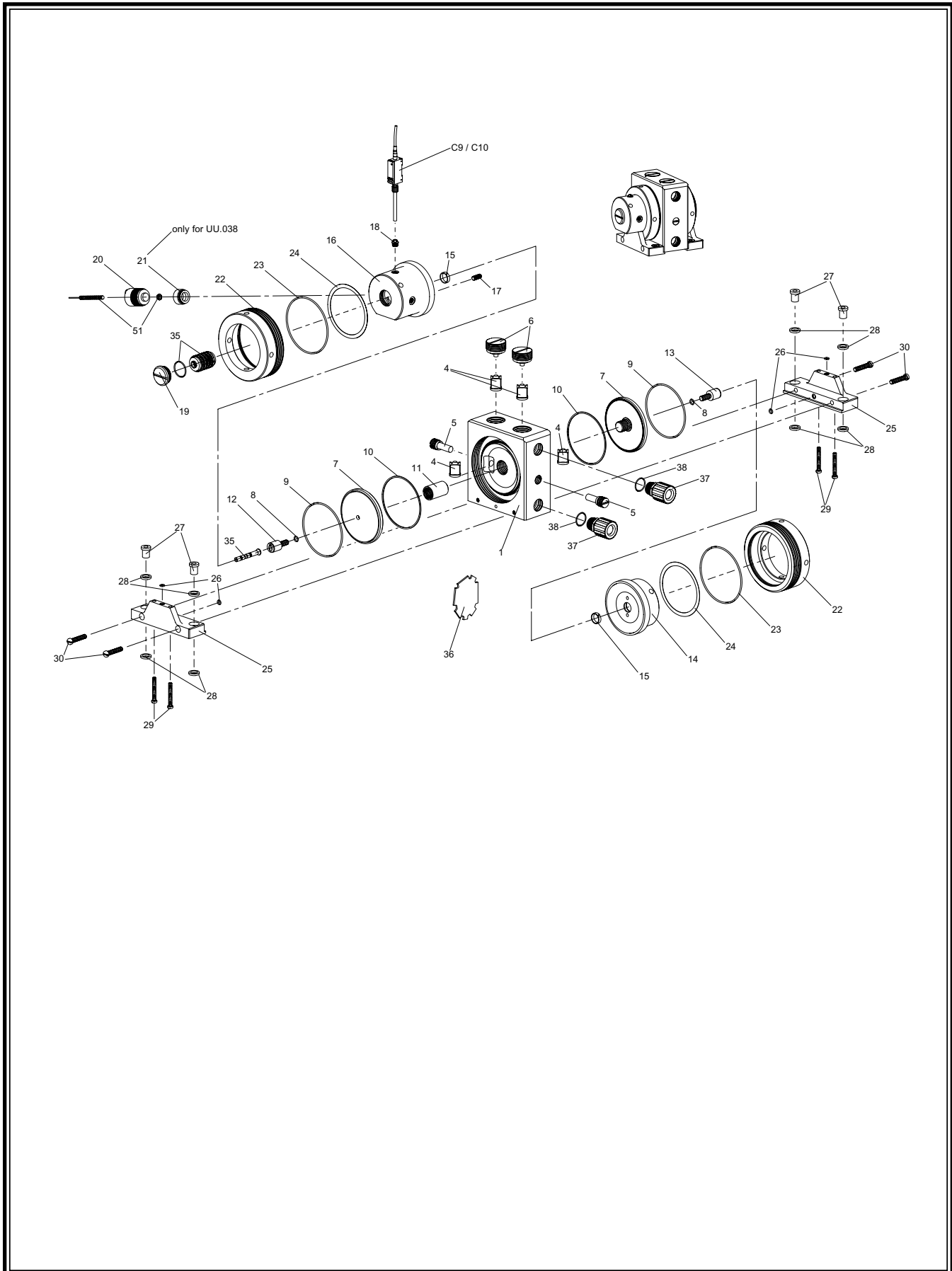

SECTION 9A (Cont.)**UNITEC™ PLASTIC PARTS LIST****Unitec™ Series Pumps - PTFE with PE Ultrapure Series**

Pump Model			UU.038/TEE	UU.050/TEE	UU2/TEE	UU3/TEE
Item	Description	Qty	P/N	P/N	P/N	P/N
1	Center housing	1	U6-10-010-69	U6-15-010-69	U6-25-010-69	U6-32-010-69
4	Check valve	4	U8-10-011-69	U8-15-011-69	U8-25-011-69	U8-32-011-69
5	Valve stop, suction valve	2	U8-10-812-69	U8-15-812-69	U8-25-812-69	U8-32-812-69
6	Valve stop, discharge valve	2	U8-10-813-69	U8-15-813-69	U8-25-813-69	U8-32-813-69
7	Diaphragm	2	U6-10-020-69	U6-15-020-69	U6-25-020-69	U6-32-020-69
8	O-ring, diaphragm inner	2	U9-04-593-74	U9-06-538-74	U9-10-544-74	U9-15-546-74
9	O-ring, diaphragm outer	2	U9-66-533-74	U9-90-586-74	U9-99-609-74	U9-99-612-74
10	Gasket, diaphragm	2	U6-10-026-69	U6-15-026-69	U6-25-026-69	U6-32-026-69
11	Cascade sleeve	1	U6-10-032-69	U6-15-032-69	U6-25-032-69	U6-32-032-69
12	Diaphragm bolt, left hand	1	U6-10-021-86	U6-15-021-86	U6-25-021-86	U6-32-021-86
13	Diaphragm bolt, right hand	1	U6-10-023-86	U6-15-023-86	U6-25-023-86	U6-32-023-86
14	Side housing, right hand	1	U6-10-014-52	U6-15-014-52	U6-25-014-52	U6-32-014-52
15	Piston ring, diaphragm bolt	2	U8-10-825-61	U8-15-825-61	U8-25-825-61	U8-32-825-61
16	Side housing, left hand	1	U6-10-015-52	U6-15-015-52	U6-25-015-52	U6-32-015-52
17	Set screw DIN 551	1	U9-06-201-53	U9-06-201-53	U9-10-206-53	U9-12-207-53
18	Plug GPN 730	1	U730-R 1/4	U730-R 1/4	U730-R 1/4	U730-R 1/4
19	Air valve cover	1	U8-15-731-52	U8-15-731-52	U8-25-731-52	U8-32-731-52
20	Muffler, cpl.	1	U1-08-244-51	U1-08-244-51	U1-15-244-51	U1-40-244-51
21	Adapter, muffler	1	U6-10-033-52	-	-	-
22	Union nut	2	U6-10-029-80	U6-15-029-80	U6-25-029-80	U6-32-029-80
23	O-ring, union nut	2	U9-73-660-74	U9-98-661-74	U9-99-662-74	U9-99-663-74
24	Sliding ring	2	U6-10-030-60	U6-15-030-60	U6-25-030-60	U6-32-030-60
25	Base frame	2	U6-10-017-52	U6-15-017-52	U6-25-017-52	U6-32-017-52
26	O-ring, air channel	4	U9-06-538-74	U9-06-538-74	U9-08-541-74	U9-10-544-74
27	Anchor bolt bushing	4	U8-25-418-52	U8-25-418-52	U8-25-418-52	U8-25-418-52
28	Damper ring	8	U1-15-149-74	U1-15-149-74	U1-15-149-74	U1-15-149-74
29	Head screw DIN 84	4	U9-06-226-53	U9-06-227-53	U9-08-227-53	U9-08-227-53
30	Head screw DIN 84	4	U9-10-227-53	U9-10-227-53	U9-10-227-53	U9-10-227-53
35	Uni-Flo™ Air Valve Assembly	1	U6-10-201-84	U6-15-201-84	U6-25-201-84	U6-32-201-84
36	Mounting tool	1	U6-10-000-53	U6-10-000-53	U6-10-000-53	U6-10-000-53

Unitec™ Series Pumps - PTFE with PTFE Ultrapure Series

Pump Model			UU.038/TTT	UU.050/TTT
Item	Description	Qty	P/N	P/N
1	Center housing	1	U6-10-010-69	U6-15-010-69
4	Check valve	4	U8-10-011-69	U8-15-011-69
5	Valve stop, suction valve	2	U8-10-812-69	U8-15-812-69
6	Valve stop, discharge valve	2	U8-10-813-69	U8-15-813-69
7	Diaphragm	2	U6-10-020-69	U6-15-020-69
8	O-ring, diaphragm inner	2	U9-04-593-74	U9-06-538-74
9	O-ring, diaphragm outer	2	U9-66-533-74	U9-90-586-74
10	Gasket, diaphragm	2	U6-10-026-69	U6-15-026-69
11	Cascade sleeve	1	U6-10-032-69	U6-15-032-69
12	Diaphragm bolt, left hand	1	U6-10-021-86	U6-15-021-86
13	Diaphragm bolt, right hand	1	U6-10-023-86	U6-15-023-86
14	Side housing, right hand	1	U6-10-014-65	U6-15-014-65
15	Piston ring, diaphragm bolt	2	U8-10-825-61	U8-15-825-61
16	Side housing, left hand	1	U6-10-015-65	U6-15-015-65
17	Set screw DIN 551	1	U9-06-201-53	U9-06-201-53
18	Plug GPN 730	1	U730-R 1/4	U730-R 1/4
19	Air valve cover	1	U8-15-731-52	U8-15-731-52
20	Muffler, cpl.	1	U1-08-244-51	U1-08-244-51
21	Adapter, muffler	1	U6-10-033-52	-
22	Union nut	2	U6-10-029-86	U6-15-029-86
23	O-ring, union nut	2	U9-73-660-74	U9-98-661-74
24	Sliding ring	2	U6-10-030-60	U6-15-030-60
25	Base frame	2	U6-10-017-52	U6-15-017-52
26	O-ring, air channel	4	U9-06-538-74	U9-06-538-74
27	Anchor bolt bushing	4	U8-25-418-52	U8-25-418-52
28	Damper ring	8	U1-15-149-74	U1-15-149-74
29	Head screw DIN 84	4	U9-06-226-53	U9-06-227-53
30	Head screw DIN 84	4	U9-10-227-53	U9-10-227-53
35	Uni-Flo™ Air Valve Assembly	1	U6-10-201-84	U6-15-201-84
36	Mounting tool	1	U6-10-000-53	U6-10-000-53
37	Flaretek® Conn., PFA pipe	2	U1-10-012-57	U1-15-012-57
38	O-ring, Flaretek® Conn.	2	U9-16-559-74	U9-17-557-74



SECTION 9A (Cont.)**UNITEC™ PLASTIC PARTS LIST****Unitec™ Series Pumps - PE with PE Ultrapure Series**

Pump Model			UU.050/EEE	UU2/EEE	UU3/EEE
Item	Description	Qty	P/N	P/N	P/N
1	Center housing	1	U6-15-010-52	U6-25-010-52	U6-32-010-52
4	Check valve	4	U8-15-011-52	U8-25-011-52	U8-32-011-52
5	Valve stop, suction valve	2	U8-15-812-69	U8-25-812-69	U8-32-812-69
6	Valve stop, discharge valve	2	U8-15-813-69	U8-25-813-69	U8-32-813-69
7	Diaphragm	2	U6-15-120-52	U6-25-120-52	U6-32-120-52
8	O-ring, diaphragm inner	2	U9-06-538-74	U9-10-544-74	U9-15-546-74
9	O-ring, diaphragm outer	2	U9-90-586-74	U9-99-609-74	U9-99-612-74
10	Gasket, diaphragm	2	U6-15-126-69	U6-25-126-69	U6-32-126-69
11	Cascade sleeve	1	U6-15-032-69	U6-25-032-69	U6-32-032-69
12	Diaphragm bolt, left hand	1	U6-15-021-86	U6-25-021-86	U6-32-021-86
13	Diaphragm bolt, right hand	1	U6-15-023-86	U6-25-023-86	U6-32-023-86
14	Side housing, right hand	1	U6-15-014-52	U6-25-014-52	U6-32-014-52
15	Piston ring, diaphragm bolt	2	U8-15-825-61	U8-25-825-61	U8-32-825-61
16	Side housing, left hand	1	U6-15-015-52	U6-25-015-52	U6-32-015-52
17	Set screw DIN 551	1	U9-06-201-53	U9-10-206-53	U9-12-207-53
18	Plug GPN 730	1	U730-R 1/4	U730-R 1/4	U730-R 1/4
19	Air valve cover	1	U8-15-731-52	U8-25-731-52	U8-32-731-52
20	Muffler, cpl.	1	U1-08-244-51	U1-15-244-51	U1-40-244-51
22	Union nut	2	U6-15-029-53	U6-25-029-53	U6-32-029-53
23	O-ring, union nut	2	U9-98-661-74	U9-99-662-74	U9-99-663-74
24	Sliding ring	2	U6-15-030-60	U6-25-030-60	U6-32-030-60
25	Base frame	2	U6-15-017-52	U6-25-017-52	U6-32-017-52
26	O-ring, air channel	4	U9-06-538-74	U9-08-541-74	U9-10-544-74
27	Anchor bolt bushing	4	U8-25-418-52	U8-25-418-52	U8-25-418-52
28	Damper ring	8	U1-15-149-74	U1-15-149-74	U1-15-149-74
29	Head screw DIN 84	4	U9-06-227-53	U9-08-227-53	U9-08-227-53
30	Head screw DIN 84	4	U9-10-227-53	U9-10-227-53	U9-10-227-53
35	Uni-Flo™ Air Valve Assembly	1	U6-15-201-84	U6-25-201-84	U6-32-201-84
36	Mounting tool	1	U6-10-000-53	U6-10-000-53	U6-10-000-53



WARRANTY

Each and every product manufactured by Wilden Pump and Engineering, LLC is built to meet the highest standards of quality. Every pump is functionally tested to insure integrity of operation.

Wilden Pump and Engineering, LLC warrants that pumps, accessories and parts manufactured or supplied by it to be free from defects in material and workmanship for a period of one year from date of startup or two years from date of shipment, whichever comes first. Failure due to normal wear, misapplication, or abuse is, of course, excluded from this warranty.

Since the use of Wilden pumps and parts is beyond our control, we cannot guarantee the suitability of any pump or part for a particular application and Wilden Pump and Engineering, LLC shall not be liable for any consequential damage or expense arising from the use or misuse of its products on any application. Responsibility is limited solely to replacement or repair of defective Wilden pumps and parts.

All decisions as to the cause of failure are the sole determination of Wilden Pump and Engineering, LLC.

Prior approval must be obtained from Wilden for return of any items for warranty consideration and must be accompanied by the appropriate MSDS for the product(s) involved. A Return Goods Tag, obtained from an authorized Wilden distributor, must be included with the items which must be shipped freight prepaid.

The foregoing warranty is exclusive and in lieu of all other warranties expressed or implied (whether written or oral) including all implied warranties of merchantability and fitness for any particular purpose. No distributor or other person is authorized to assume any liability or obligation for Wilden Pump and Engineering, LLC other than expressly provided herein.

PLEASE PRINT OR TYPE AND FAX TO WILDEN

Item # _____ Serial # _____

Company Purchased From _____

Your Company Name _____

Industry _____

Your Name _____ Title _____

Your Address (Street) _____

(City) _____ (State) _____ (Postal Code) _____ (Country) _____

(Telephone) _____ (Fax) _____ (e-mail) _____

Number of pumps in facility? _____ Diaphragm _____ Centrifugal

_____ Gear _____ Submersible _____ Lobe _____ Other _____

Fluid being pumped _____

How did you hear of Wilden Pump? _____ Trade Journal _____ Trade Show

_____ Internet/E-mail _____ Distributor _____ Other _____

ONCE COMPLETE, FAX TO (909) 783-3440

NOTE: WARRANTY VOID IF PAGE IS NOT FAXED TO WILDEN

