

# PV810

Advanced™ Series **METAL** Pumps

# EOM

Engineering  
Operation &  
Maintenance

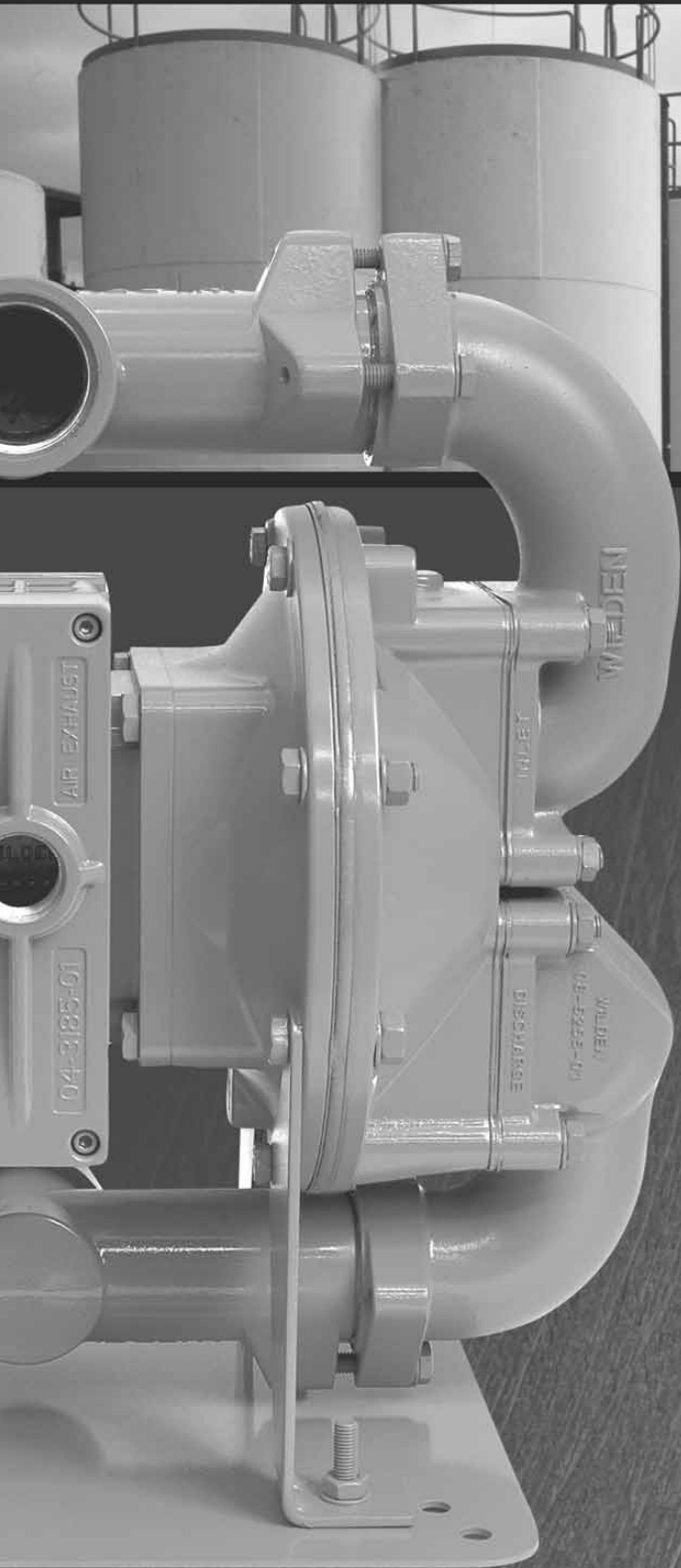

Advance your process



**PRO-FLO V™**  
PROGRESSIVE PUMP TECHNOLOGY

# WILDEN®

A **DOVER** COMPANY

WIL-11141-E-04  
REPLACES WIL-11141-E-03

**TABLE OF CONTENTS**

**SECTION 1 CAUTIONS—READ FIRST! .....1**

**SECTION 2 WILDEN PUMP DESIGNATION SYSTEM .....2**

**SECTION 3 HOW IT WORKS—PUMP & AIR DISTRIBUTION SYSTEM .....3**

**SECTION 4 DIMENSIONAL DRAWING .....4**

**SECTION 5 PERFORMANCE**

    A. Performance Curve .....5

    B. Suction Lift Curve .....5

**SECTION 6 SUGGESTED INSTALLATION, OPERATION & TROUBLESHOOTING .....6**

**SECTION 7 DISASSEMBLY / REASSEMBLY .....9**

**SECTION 8 EXPLODED VIEW & PARTS LISTING**

    Wetted .....18

















    Center Section Assembly .....20

    Inlet Flap Assemblies .....22

**SECTION 9 ELASTOMER OPTIONS .....24**



## CAUTIONS—READ FIRST!

-  **CAUTION:** Do not apply compressed air to the exhaust port — pump will not function.
-  **CAUTION:** Do not over-lubricate air supply — excess lubrication will reduce pump performance. Pump is pre-lubed.
-  **TEMPERATURE LIMITS:**
- |                                    |                    |                |
|------------------------------------|--------------------|----------------|
| Neoprene                           | -17.7°C to 93.3°C  | 0°F to 200°F   |
| Buna-N                             | -12.2°C to 82.2°C  | 10°F to 180°F  |
| EPDM                               | -51.1°C to 137.8°C | -60°F to 280°F |
| Viton®                             | -40°C to 176.7°C   | -40°F to 350°F |
| Saniflex™                          | -28.9°C to 104.4°C | -20°F to 220°F |
| Polytetrafluoroethylene (PTFE)     |                    |                |
|                                    | 4.4°C to 104.4°C   | 40°F to 220°F  |
| Polyurethane                       | -12.2°C to 65.6°C  | 10°F to 150°F  |
| Tetra-Flex™ PTFE w/Neoprene Backed |                    |                |
|                                    | 4.4°C to 107.2°C   | 40°F to 225°F  |
| Tetra-Flex™ PTFE w/EPDM Backed     |                    |                |
|                                    | -10°C to 137°C     | 14°F to 280°F  |
- NOTE: Not all materials are available for all models. Refer to Section 2 for material options for your pump.
-  **CAUTION:** When choosing pump materials, be sure to check the temperature limits for all wetted components. Example: Viton® has a maximum limit of 176.7°C (350°F) but polypropylene has a maximum limit of only 79°C (175°F).
-  **CAUTION:** Maximum temperature limits are based upon mechanical stress only. Certain chemicals will significantly reduce maximum safe operating temperatures. Consult Chemical Resistance Guide (E4) for chemical compatibility and temperature limits.
-  **WARNING:** Prevention of static sparking — If static sparking occurs, fire or explosion could result. Pump, valves, and containers must be grounded to a proper grounding point when handling flammable fluids and whenever discharge of static electricity is a hazard.
-  **CAUTION:** Do not exceed 8.6 bar (125 psig) air supply pressure.
-  **CAUTION:** The process fluid and cleaning fluids must be chemically compatible with all wetted pump components. Consult Chemical Resistance Guide (E4).
-  **CAUTION:** Do not exceed 82°C (180°F) air inlet temperature for Pro-Flo V™ models.
-  **CAUTION:** Pumps should be thoroughly flushed before installing into process lines. FDA and USDA approved pumps should be cleaned and/or sanitized before being used.
-  **CAUTION:** Always wear safety glasses when operating pump. If diaphragm rupture occurs, material being pumped may be forced out air exhaust.
-  **CAUTION:** Before any maintenance or repair is attempted, the compressed air line to the pump should be disconnected and all air pressure allowed to bleed from pump. Disconnect all intake, discharge and air lines. Drain the pump by allowing any fluid to flow into a suitable container.
-  **CAUTION:** Blow out air line for 10 to 20 seconds before attaching to pump to make sure all pipeline debris is clear. Use an in-line air filter. A 5µ (micron) air filter is recommended.
-  **NOTE:** Before starting disassembly, mark a line from each liquid chamber to its corresponding air chamber. This line will assist in proper alignment during reassembly.
-  **CAUTION:** Pro-Flo V™ is available in both submersible and non-submersible options. Do not use non-submersible Pro-Flo V™ models in submersible applications. Turbo-Flo™ pumps can also be used in submersible applications.
-  **CAUTION:** Tighten all hardware prior to installation.

**WILDEN PUMP DESIGNATION SYSTEM**

**PV810 METAL**

**51 mm (2") Pump**  
**Maximum Flow Rate:**  
**655 lpm (173 gpm)**

**LEGEND**

**PV810 / XXXXX / XXX / XX / XXX / XXXX**

MODEL

WETTED PARTS

OUTER PISTONS

AIR CHAMBERS

CENTER BLOCK

AIR VALVE

DIAPHRAGMS

FLAP VALVES

VALVE SEAT

GASKETS

SPECIALTY  
CODE  
(if applicable)

**MATERIAL CODES**

**MODEL**

810 = 51 mm (2") ADVANCED™ TOP  
INLET/BOTTOM DISCHARGE

**WETTED PARTS  
AND OUTER PISTON**

AM = ALUMINUM / MILD STEEL  
WM = DUCTILE IRON / MILD STEEL

**AIR CHAMBERS**

A = ALUMINUM

**CENTER BLOCK**

A = ALUMINUM

**AIR VALVE**

A = ALUMINUM

**DIAPHRAGMS**

BNS = BUNA-N (red dot)  
NES = NEOPRENE (green dot)

**FLAP VALVES**

BNS = BUNA-N (red dot)  
NES = NEOPRENE (green dot)

**VALVE SEAT**

M = MILD STEEL

**GASKETS**

BN = BUNA-N (red dot)  
NE = NEOPRENE (green dot)

**SPECIALTY CODES**

- 0677 Horizontal Center Ported, NPT Threaded
- 0678 Horizontal Center Ported, BSPT Threaded
- 0320 Submersible center block

NOTE: MOST ELASTOMERIC MATERIALS USE COLORED DOT FOR IDENTIFICATION

**HOW IT WORKS—PUMP**

The Wilden diaphragm pump is an air-operated, positive displacement, self-priming pump. These drawings show flow pattern through the pump upon its initial stroke. It is assumed the pump has no fluid in it prior to its initial stroke.

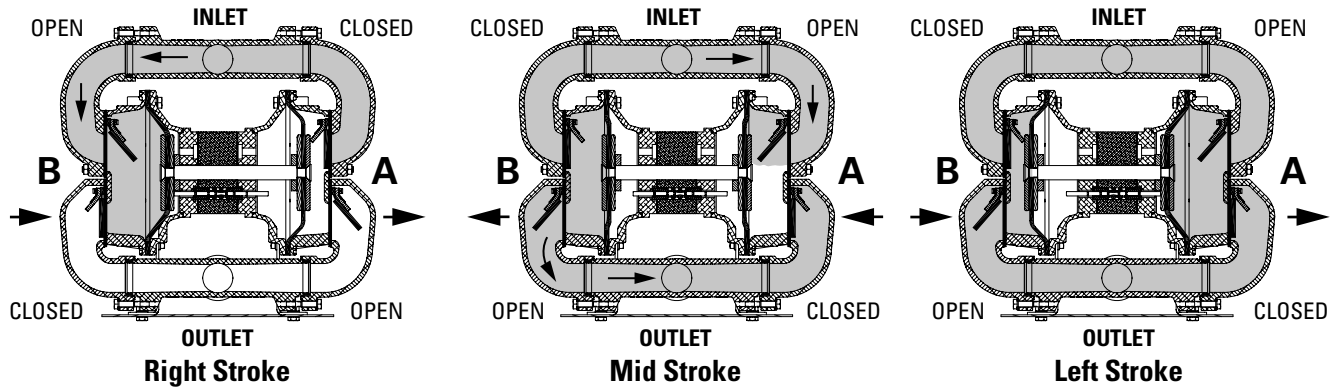

**FIGURE 1** The air valve directs pressurized air to the back side of diaphragm A. The compressed air is applied directly to the liquid column separated by elastomeric diaphragms. The diaphragm acts as a separation membrane between the compressed air and liquid, balancing the load and removing mechanical stress from the diaphragm. The compressed air moves the diaphragm away from the center of the pump. The opposite diaphragm is pulled in by the shaft connected to the pressurized diaphragm. Diaphragm B is on its suction stroke; air behind the diaphragm has been forced out to atmosphere through the exhaust port of the pump. The movement of diaphragm B toward the center of the pump creates a vacuum within chamber B. Atmospheric pressure forces fluid into the inlet manifold forcing the inlet check valve off its seat. Liquid is free to move past the inlet check valve and fill the liquid chamber (see shaded area).

**FIGURE 2** When the pressurized diaphragm, diaphragm A, reaches the limit of its discharge stroke, the air valve redirects pressurized air to the back side of diaphragm B. The pressurized air forces diaphragm B away from the center while pulling diaphragm A to the center. Diaphragm B is now on its discharge stroke. Diaphragm B forces the inlet check valve onto its seat due to the hydraulic forces developed in the liquid chamber and manifold of the pump. These same hydraulic forces lift the discharge check valve off its seat, forcing fluid to flow through the pump discharge. The movement of diaphragm A toward the center of the pump creates a vacuum within liquid chamber A. Atmospheric pressure forces fluid into the inlet manifold of the pump. The inlet check valve is forced off its seat allowing the fluid being pumped to fill the liquid chamber.

**FIGURE 3** At completion of the stroke, the air valve again redirects air to the back side of diaphragm A, which starts diaphragm B on its suction stroke. As the pump reaches its original starting point, each diaphragm has gone through one suction and one discharge stroke. This constitutes one complete pumping cycle. The pump may take several cycles to completely prime depending on the conditions of the application.

**NOTE:** Unlike other Wilden pumps, the fluid inlet of the Brahma Advanced™ pump is located at the top and the fluid discharge is located at the bottom of the pump.

**HOW IT WORKS—AIR DISTRIBUTION SYSTEM**

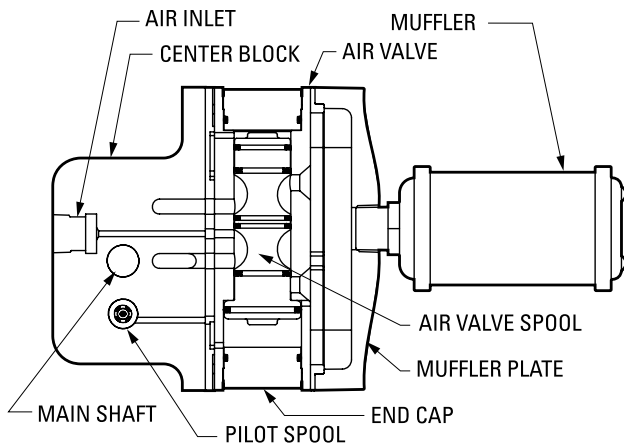

The Pro-Flo V™ patented air distribution system incorporates two moving parts: the air valve spool and the pilot spool. The heart of the system is the air valve. This valve design incorporates an unbalanced spool. The smaller end of the spool is pressurized continuously, while the large end is alternately pressurized, then exhausted, to move the spool. The air valve spool directs pressurized air to one air chamber while exhausting the other. The air causes the main shaft/diaphragm assembly to shift to one side — discharging liquid on that side and pulling liquid in on the other side. When the shaft reaches the end of its stroke, the inner piston actuates the pilot spool, which pressurizes and exhausts the large end of the air valve spool. The repositioning of the air valve spool routes the air to the other air chamber.

**DIMENSIONAL DRAWINGS**

**PV810 ADVANCED™ METAL**

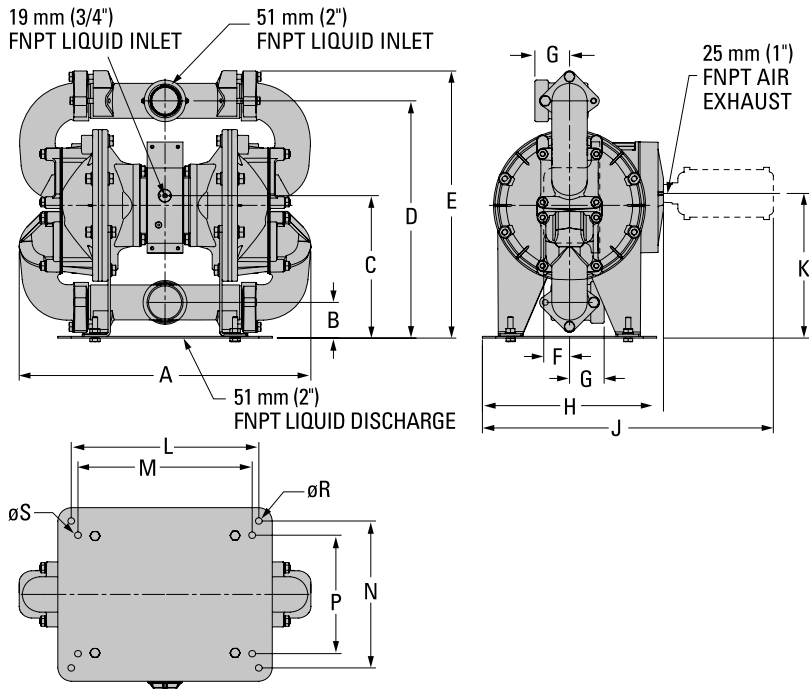

**DIMENSIONS**

ITEM	METRIC (mm)	STANDARD (inch)
A	554	21.8
B	69	2.7
C	272	10.7
D	452	17.8
E	508	20.0
F	48	1.9
G	66	2.6
H	343	13.5
J	551	21.7
K	274	10.8
L	356	14.0
M	330	13.0
N	279	11.0
P	226	8.9
R	13	0.5
S	13	0.5



**SUGGESTED INSTALLATION**

Wilden pumps are designed to meet the performance requirements of even the most demanding pumping applications. They have been designed and manufactured to the highest standards and are available in a variety of wetted path materials to meet your chemical resistance needs. Refer to the performance section of this manual for an in-depth analysis of the performance characteristics of your pump. Wilden offers the widest variety of elastomer options in the industry to satisfy temperature, chemical compatibility, abrasion resistance and flex concerns.

The suction pipe size should be at least the equivalent or larger than the diameter size of the suction inlet on your Wilden pump. The suction hose must be non-collapsible, reinforced type as these pumps are capable of pulling a high vacuum. Discharge piping should also be the equivalent or larger than the diameter of the pump discharge which will help reduce friction losses. It is critical that all fittings and connections are airtight or a reduction or loss of pump suction capability will result.

**INSTALLATION:** Months of careful planning, study, and selection efforts can result in unsatisfactory pump performance if installation details are left to chance.

Premature failure and long term dissatisfaction can be avoided if reasonable care is exercised throughout the installation process.

**LOCATION:** Noise, safety and other logistical factors usually dictate where equipment will be situated on the production floor. Multiple installations with conflicting requirements can result in congestion of utility areas, leaving few choices for additional pumps.

Within the framework of these and other existing conditions, every pump should be located in such a way that six key factors are balanced against each other to maximum advantage.

**ACCESS:** First of all, the location should be accessible. If it's easy to reach the pump, maintenance personnel will have an easier time carrying out routine inspections and adjustments. Should major repairs become necessary, ease of access can play a key role in speeding the repair process and reducing total downtime.

**AIR SUPPLY:** Every pump location should have an air line large enough to supply the volume of air necessary to achieve the desired pumping rate. Use air pressure up to a maximum of 8.6 bar (125 psig) depending on pumping requirements.

For best results, the pumps should use a 5 $\mu$  (micron) air filter, needle valve and regulator. The use of an air filter before the pump will ensure that the majority of any pipeline contaminants will be eliminated.

**SOLENOID OPERATION:** When operation is controlled by a solenoid valve in the air line, three-way valves should be used. This valve allows trapped air between the valve and the pump to bleed off which improves pump performance. Pumping volume can be estimated by counting the number of strokes per minute and then multiplying the figure by the displacement per stroke.

**MUFFLER:** Sound levels are reduced below OSHA specifications using the standard Wilden muffler. Other mufflers can be used to further reduce sound levels, but they usually reduce pump performance.

**ELEVATION:** Selecting a site that is well within the pump's dynamic lift capability will assure that loss-of-prime issues will be eliminated. In addition, pump efficiency can be adversely affected if proper attention is not given to site location.

**PIPING:** Final determination of the pump site should not be made until the piping challenges of each possible location have been evaluated. The impact of current and future installations should be considered ahead of time to make sure that inadvertent restrictions are not created for any remaining sites.

The best choice possible will be a site involving the shortest and straightest hook-up of suction and discharge piping. Unnecessary elbows, bends, and fittings should be avoided. Pipe sizes should be selected to keep friction losses within practical limits. All piping should be supported independently of the pump. In addition, the piping should be aligned to avoid placing stress on the pump fittings.

Flexible hose can be installed to aid in absorbing the forces created by the natural reciprocating action of the pump. If the pump is to be bolted down to a solid location, a mounting pad placed between the pump and the foundation will assist in minimizing pump vibration. Flexible connections between the pump and rigid piping will also assist in minimizing pump vibration. If quick-closing valves are installed at any point in the discharge system, or if pulsation within a system becomes a problem, a surge suppressor (SD Equalizer®) should be installed to protect the pump, piping and gauges from surges and water hammer.

If the pump is to be used in a self-priming application, make sure that all connections are airtight and that the suction lift is within the model's ability. Note: Materials of construction and elastomer material have an effect on suction lift parameters. Please refer to the performance section for specifics.

When pumps are installed in applications involving flooded suction or suction head pressures, a gate valve should be installed in the suction line to permit closing of the line for pump service.

Pumps in service with a positive suction head are most efficient when inlet pressure is limited to 0.5–0.7 bar (7–10 psig). Premature diaphragm failure may occur if positive suction is 0.7 bar (10 psig) and higher.

**SUBMERSIBLE APPLICATIONS:** Turbo-Flo™ pumps can be used for submersible applications. Pro-Flo V™ pumps can also be used for submersible applications.

**NOTE:** Accu-Flo™ pumps are not submersible.

**ALL WILDEN PUMPS ARE CAPABLE OF PASSING SOLIDS. A STRAINER SHOULD BE USED ON THE PUMP INTAKE TO ENSURE THAT THE PUMP'S RATED SOLIDS CAPACITY IS NOT EXCEEDED.**

**CAUTION: DO NOT EXCEED 8.6 BAR (125 PSIG) AIR SUPPLY PRESSURE [3.4 BAR (50 PSIG) FOR UL LISTED MODELS].**

## SUGGESTED INSTALLATION

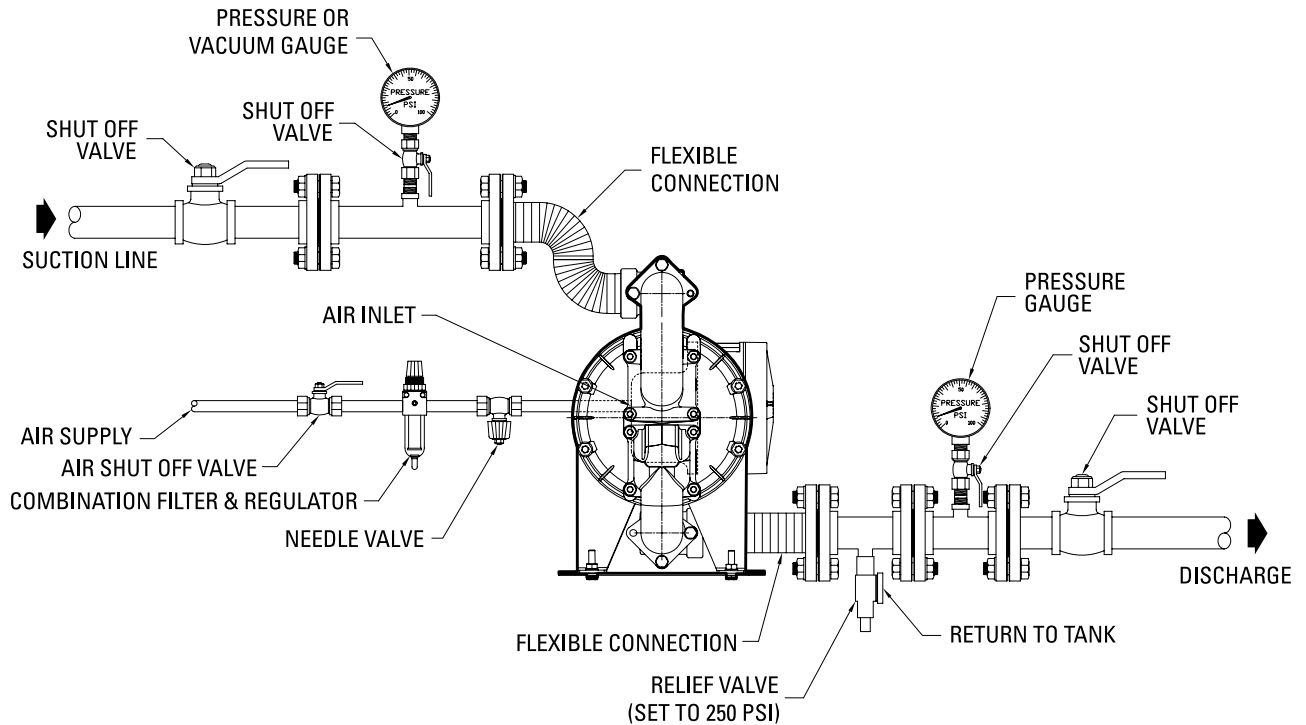

**NOTE:** In the event of a power failure, the shut off valve should be closed, if the restarting of the pump is not desirable once power is regained.

**NOTE:** The fluid inlet to the Brahma Advanced™ pump is located at the top and the fluid discharge is located at the bottom of the pump.

**AIR OPERATED PUMPS:** To stop the pump from operating in an emergency situation, simply close the shut off valve (user supplied) installed in the air supply line. A properly functioning valve will stop the air supply to the pump, therefore stopping output. This shut off valve should be located far enough away from the pumping equipment such that it can be reached safely in an emergency situation.

## SUGGESTED OPERATION & MAINTENANCE

**OPERATION:** The PV810 is pre-lubricated, and do not require in-line lubrication. Additional lubrication will not damage the pump, however if the pump is heavily lubricated by an external source, the pump's internal lubrication may be washed away. If the pump is then moved to a non-lubricated location, it may need to be disassembled and re-lubricated as described in the ASSEMBLY/DISASSEMBLY INSTRUCTIONS.

Pump discharge rate can be controlled by limiting the volume and/or pressure of the air supply to the pump. An air regulator is used to regulate air pressure. A needle valve is used to regulate volume. Pump discharge rate can also be controlled by throttling the pump discharge by partially closing a valve in the discharge line of the pump. This action increases friction loss which reduces flow rate. (See Section 5.) This is useful when the need exists to control the pump from a remote location. When the pump discharge pressure equals or exceeds the air supply pressure, the pump will stop; no bypass or pressure relief valve is needed, and pump damage will not occur. The pump has reached a "deadhead" situation and can be

restarted by reducing the fluid discharge pressure or increasing the air inlet pressure. The Wilden Pro-Flo® and Pro-Flo V™ pumps run solely on compressed air and do not generate heat, therefore your process fluid temperature will not be affected.

**MAINTENANCE AND INSPECTIONS:** Since each application is unique, maintenance schedules may be different for every pump. Frequency of use, line pressure, viscosity and abrasiveness of process fluid all affect the parts life of a Wilden pump. Periodic inspections have been found to offer the best means for preventing unscheduled pump downtime. Personnel familiar with the pump's construction and service should be informed of any abnormalities that are detected during operation.

**RECORDS:** When service is required, a record should be made of all necessary repairs and replacements. Over a period of time, such records can become a valuable tool for predicting and preventing future maintenance problems and unscheduled downtime. In addition, accurate records make it possible to identify pumps that are poorly suited to their applications.

## TROUBLESHOOTING

### ***Pump will not run or runs slowly.***

1. Ensure that the air inlet pressure is at least 0.4 bar (5 psig) above startup pressure and that the differential pressure (the difference between air inlet and liquid discharge pressures) is not less than 0.7 bar (10 psig).
2. Check air inlet filter for debris (see recommended installation).
3. Check for extreme air leakage (blow by) which would indicate worn seals/bores in the air valve, pilot spool, main shaft.
4. Disassemble pump and check for obstructions in the air passageways or objects which would obstruct the movement of internal parts.
5. Check mating surfaces of flap valve assembly.
6. Check for sticking check valves. If material being pumped is not compatible with pump elastomers, swelling may occur. Replace check valves with proper elastomers.
7. Check for broken inner piston which will cause the air valve spool to be unable to shift.
8. Remove plug from pilot spool exhaust.

### ***Pump runs but little or no product flows.***

1. Check for pump cavitation; slow pump speed down to allow thick material to flow into liquid chambers.

2. Verify that vacuum required to lift liquid is not greater than the vapor pressure of the material being pumped (cavitation).
3. Check for sticking check valves. If material being pumped is not compatible with pump elastomers, swelling may occur. Replace check valves with proper elastomers.

### ***Pump air valve freezes.***

1. Check for excessive moisture in compressed air. Either install a dryer or hot air generator for compressed air. Alternatively, a coalescing filter may be used to remove the water from the compressed air in some applications.

### ***Air bubbles in pump discharge.***

1. Check for ruptured diaphragm.
2. Check tightness of outer pistons (refer to Section 7).
3. Check tightness of fasteners and integrity of o-rings and seals, especially at intake manifold.
4. Ensure pipe connections are airtight.

### ***Product comes out air exhaust.***

1. Check for diaphragm rupture.
2. Check tightness of outer pistons to shaft.

## PUMP DISASSEMBLY

### TOOLS REQUIRED:

- 7/32" Hex Head Wrench
- 3/8" Hex Head Wrench
- 7/16" Wrench
- 9/16" Wrench
- 5/8" Wrench

**CAUTION:** Before any maintenance or repair is attempted, the compressed air line to the pump should be disconnected and all air pressure allowed to bleed from the pump. Disconnect all intake, discharge and air lines. Drain the pump by turning it upside down and allowing any fluid to flow into a suitable container. Be aware of any hazardous effects of contact with your process fluid.

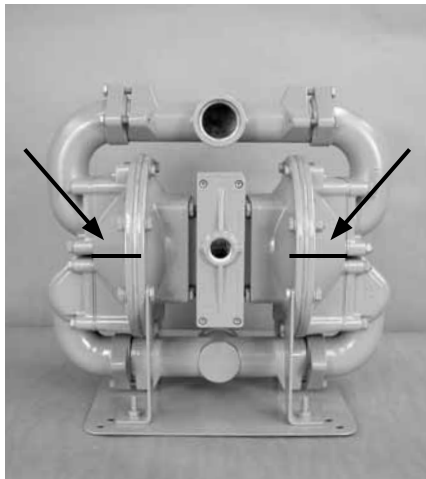

#### Step 1

Before starting disassembly, mark a line from each liquid chamber to the corresponding air chamber. This will assist in proper alignment during reassembly.

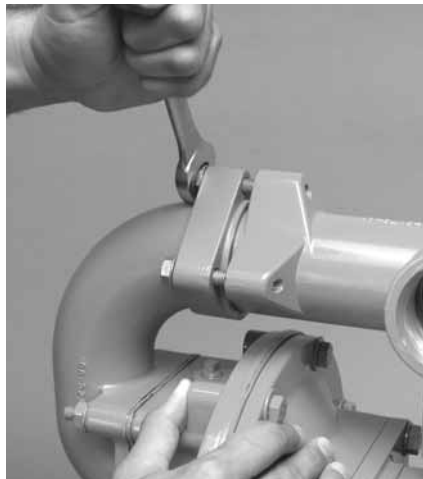

#### Step 2

Using a 9/16" wrench, remove the fasteners that connect the inlet elbow to the inlet T-section.



#### Step 3

Using a 9/16" wrench, remove the fastener that connects the elbow to the liquid chamber.

## PUMP DISASSEMBLY



### Step 4

Next, remove the inlet elbow from the liquid chamber



### Step 5

Using a 7/16" wrench, remove the flap valve assembly from the inlet elbow. Inspect flap valves for nicks, gouges, chemical attack or abrasive wear. Note: replace worn parts with genuine Wilden parts for reliable performance.



### Step 6

Inspect manifold gasket, flap valve seat and seat gasket for nicks, gouges, chemical attack or abrasive wear.



### Step 7

Using a 9/16" mm wrench, remove the fasteners that connect the remaining inlet elbow to the inlet T-section.



### Step 8

Using a 9/16" wrench, remove the fasteners that connect the remaining inlet elbow to the liquid chamber.



### Step 9

Next, remove the remaining inlet elbow from the liquid chamber.



**Step 10**

Using a 9/16" wrench, remove the fasteners that connect the discharge elbow to the discharge T-section. To simplify this process, a socket extension can be used for easier access to the fastener.

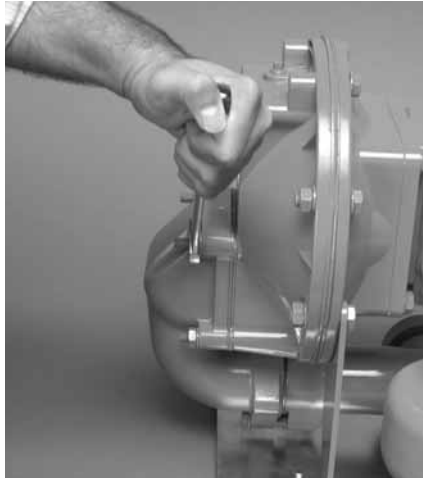

**Step 11**

Using a 9/16" wrench, remove the fasteners that connect the discharge elbow to the liquid chamber.



**Step 12**

Next, remove the discharge elbow from the liquid chamber.

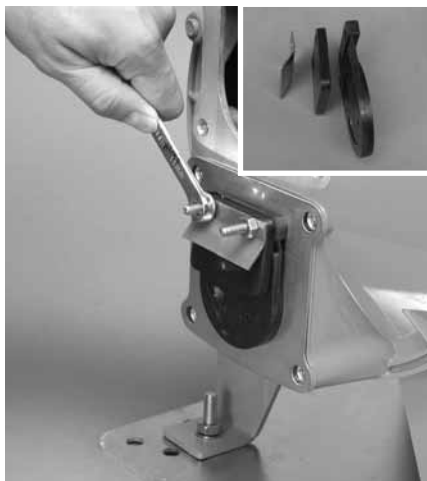

**Step 13**

Using a 7/16" wrench, remove the flap valve assembly from the liquid chamber. Inspect flap valves for nicks, gouges, chemical attack or abrasive wear. Note: replace worn parts with genuine Wilden parts for reliable performance.



**Step 14**

Inspect manifold gasket, flap valve seat and seat gasket for nicks, gouges, chemical attack or abrasive wear.



**Step 15**

Using a 9/16" wrench, remove the fasteners that connect the remaining discharge elbow to the liquid chamber.

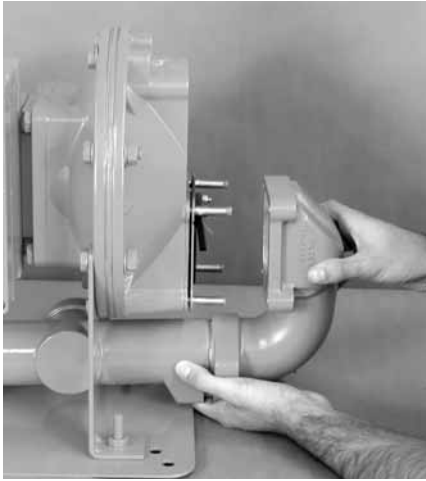

**Step 16**

Remove the discharge elbow and discharge T-section from the liquid chamber. This will allow for easy removal of the flap valve assembly. Inspect for nicks, gouges, chemical attack or abrasive wear.



**Step 17**

Using a 5/8" wrench, remove the fasteners that connect the liquid chambers to the center section.

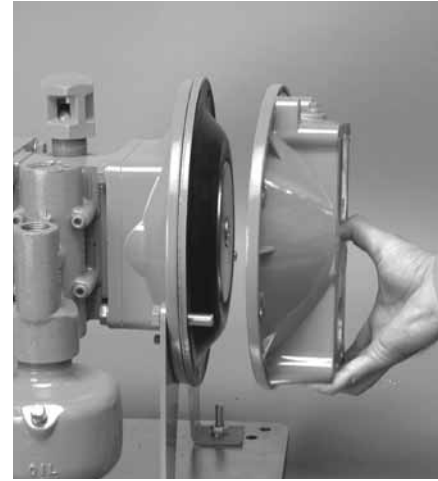

**Step 18**

Remove the liquid chamber to expose the diaphragm and outer piston.



**Step 19**

Next, remove center section assembly from pump stand.



**Step 20**

Using two 3/8" hex head wrenches, loosen the outer piston from the main shaft.

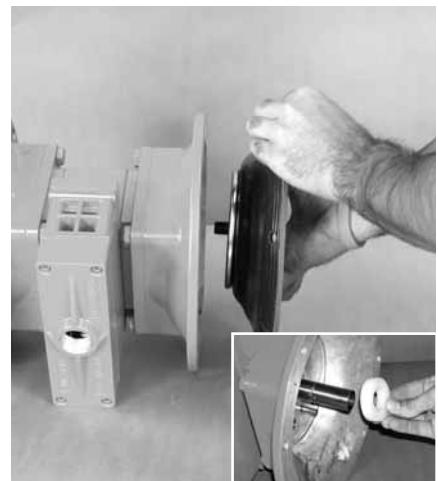

**Step 21**

After loosening the outer piston from the main shaft, the diaphragm assembly and bumper can be removed from the center section.

## PUMP DISASSEMBLY



### Step 22

Next, remove the remaining diaphragm/piston assembly, bumper and main shaft from the center section.

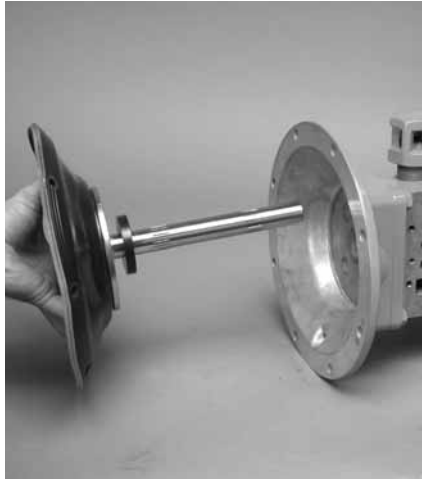

### Step 23

Remove the inner piston from the diaphragm/piston assembly by turning counterclockwise.



### Step 24

Using a 7/32" hex head wrench, loosen the fasteners that connect the air chamber to the center block by turning counterclockwise.



### Step 25

Remove the air chamber to expose the center block gasket. Inspect and replace if necessary.



### Step 26

Using a 5/8" wrench, remove the fasteners that connect the center block adapter plate to the air chamber.



### Step 27

Remove the center block adapter plate from the air chamber.

## PUMP DISASSEMBLY

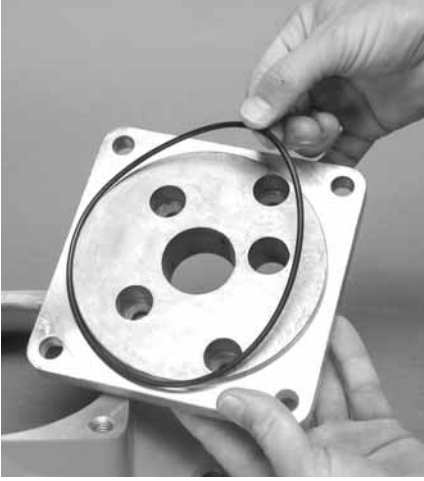

### **Step 28**

Next, remove the center block adapter o-ring and inspect for nicks, gouges, chemical attack or abrasive wear.

## AIR VALVE / CENTER SECTION DISASSEMBLY

### TOOLS REQUIRED:

- 3/16" Hex Head Wrench
- 1/4" Hex Head Wrench
- O-ring Pick

**CAUTION:** Before any maintenance or repair is attempted, the compressed air line to the pump should be disconnected and all air pressure allowed to bleed from the pump. Disconnect all intake, discharge and air lines. Drain the pump by turning it upside down and allowing any fluid to flow into a suitable container. Be aware of any hazardous effects of contact with your process fluid.



### Step 1

Using a 3/16" hex head wrench, loosen the air valve bolts.



### Step 2

Remove the muffer plate and air valve bolts from the air valve assembly exposing the muffer gasket for inspection. Replace if necessary.



### Step 3

Lift away air valve assembly and remove the air valve gasket for inspection. Replace if necessary.

## AIR VALVE / CENTER SECTION DISASSEMBLY



### Step 4

Lift away muffer plate and remove the muffer plate gasket for inspection. Inspect for nicks, gouges and chemical attack. Replace if necessary.



### Step 5

Remove the air valve end cap to expose air valve spool by simply lifting up on the end cap once the air valve bolts are removed.



### Step 6

Remove the air valve spool from the air valve body by threading one air valve bolt into the end of the air valve spool and gently sliding the spool out of the air valve body. Inspect seals for signs of wear and replace entire assembly if necessary. Use caution when handling the air valve spool to prevent damaging seals. Note: seals should not be removed from assembly. Seals are not sold separately.



### Step 7

To remove the pilot spool from the pilot spool sleeve, use an o-ring pick and gently remove the o-ring from the opposite side of the "notched end" of the pilot spool.

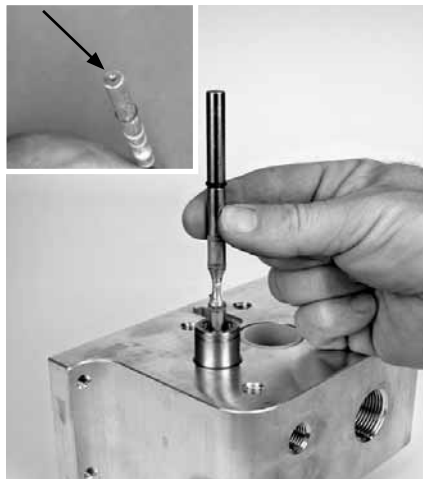

### Step 8

With the pilot spool retaining o-ring removed, gently remove the pilot spool from the pilot spool sleeve. Inspect pilot spool seals for nicks, gouges and chemical attack. Note: During reassembly, never insert the pilot spool into the pilot spool sleeve with the "notched end" first, this end incorporates the urethane o-ring and will be damaged as it slides over the ports cut in the sleeve. Also note: seals should not be removed from pilot spool. Seals are not sold separately.



### Step 9

Remove the pilot spool sleeve from the center block.

## REASSEMBLY HINTS & TIPS

### ASSEMBLY:

Upon performing applicable maintenance to the air distribution system, the pump can now be reassembled. Please refer to the disassembly instructions for photos and parts placement. To reassemble the pump, follow the disassembly instructions in reverse order. The air distribution system needs to be assembled first, then the diaphragms and finally the wetted path. The following tips will assist in the assembly process.

- Lubricate air valve bore, center section shaft and pilot spool bore with NLGI grade 2 white EP bearing grease or equivalent.
- Clean the inside of the center section shaft bore to ensure no damage is done to new shaft seals.
- A small amount NLGI grade 2 white EP bearing grease can be applied to the muffler and air valve gaskets to locate gaskets during assembly.
- Make sure that the exhaust port on the muffler plate is centered between the two exhaust ports on the center section.
- Stainless bolts should be lubed to reduce the possibility of seizing during tightening.
- Use a mallet to tap lightly on the large clamp bands to seat the diaphragm before tightening.

### PV810 MAXIMUM TORQUE SPECIFICATIONS

Air Valve	13.6 N•m (120 in-lbs)
Center Block Adapter to Center Block	27.1 N•m (20 ft-lbs)
Center Block Adapter Plate to Air Chamber	47.5 N•m (35 ft-lbs)
Outer Piston	54.2 N•m (40 ft-lbs)
Flap Valve Assembly	1.7 N•m (15 in-lbs)
Liquid Chamber to Air Chamber	32.5 N•m (24 ft-lbs)
Manifold Elbow to Liquid Chamber	13.6 N•m (18 ft-lbs)
Manifold Elbow to T-Section	20.3 N•m (15 ft-lbs)

### SHAFT SEAL INSTALLATION:

#### PRE-INSTALLATION

- Once all of the old seals have been removed, the inside of the bushing should be cleaned to ensure no debris is left that may cause premature damage to the new seals.

#### INSTALLATION

The following tools can be used to aid in the installation of the new seals:

Needle Nose Pliers  
Phillips Screwdriver  
Electrical Tape

- Wrap electrical tape around each leg of the needle nose pliers (heat shrink tubing may also be used). This is done to prevent damaging the inside surface of the new seal.
- With a new seal in hand, place the two legs of the needle nose pliers inside the seal ring. (See Figure A.)
- Open the pliers as wide as the seal diameter will allow, then with two fingers pull down on the top portion of the seal to form kidney bean shape. (See Figure B.)
- Lightly clamp the pliers together to hold the seal into the kidney shape. Be sure to pull the seal into as tight of a kidney shape as possible, this will allow the seal to travel down the bushing bore easier.
- With the seal clamped in the pliers, insert the seal into the bushing bore and position the bottom of the seal into the correct groove. Once the bottom of the seal is seated in the groove, release the clamp pressure on the pliers. This will allow the seal to partially snap back to its original shape.
- After the pliers are removed, you will notice a slight bump in the seal shape. Before the seal can be properly resized, the bump in the seal should be removed as much as possible. This can be done with either the Phillips screwdriver or your finger. With either the side of the screwdriver or your finger, apply light pressure to the peak of the bump. This pressure will cause the bump to be almost completely eliminated.
- Lubricate the edge of the shaft with NLGI grade 2 white EP bearing grease.
- Slowly insert the center shaft with a rotating motion. This will complete the resizing of the seal.
- Perform these steps for the remaining seals.

**Figure A**

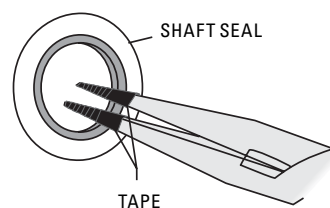

**Figure B**

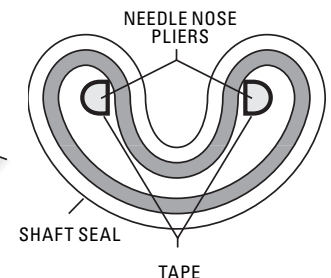

**EXPLODED VIEW AND PARTS LISTING**

**PV810 ADVANCED METAL**

Wetted Path

**EXPLODED VIEW**

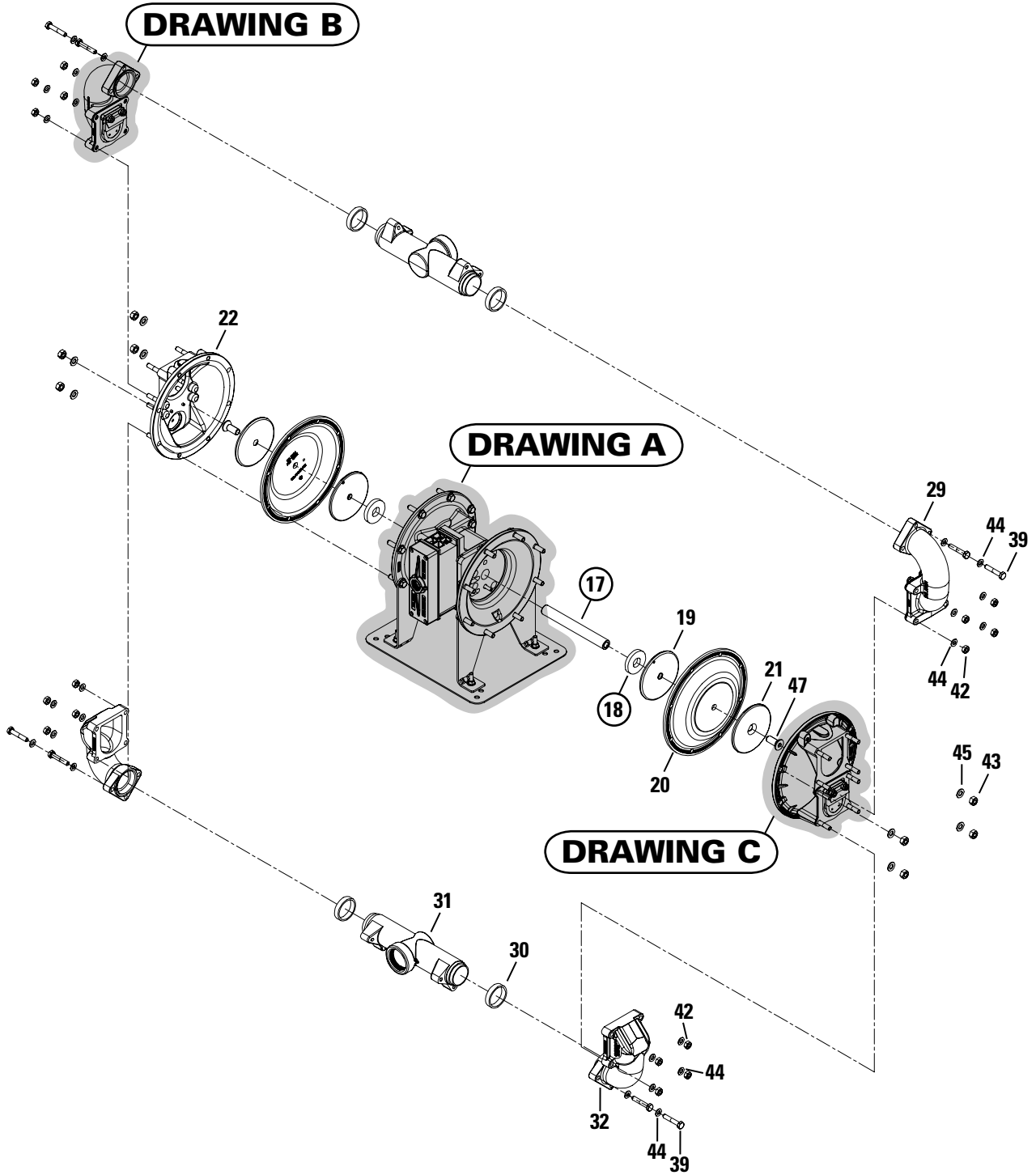

ALL CIRCLED PART IDENTIFIERS ARE INCLUDED IN CONVERSION KIT (See Section 9).

**EXPLODED VIEW AND PARTS LISTING**

**PV810 ADVANCED METAL**

**Wetted Path**

**PARTS LISTING**

Item	Description	Qty.	PV810/ AMAAD/.../[677] P/N	PV810/ WMAAD/.../[677] P/N	PV810/ AMAAD/.../[678] P/N	PV810/ WMAAD/.../[678] P/N
1	Pro-Flo V™ Assembly, Air Valve¹	1	04-2030-01	04-2030-01	04-2030-01	04-2030-01
2	O-Ring (-225), End Cap (1.859 x .139)	2	04-3290-52-700	04-3290-52-700	04-3290-52-700	04-3290-52-700
3	End Cap	2	04-2340-01	04-2340-01	04-2340-01	04-2340-01
4	Screw, SHC, Air Valve (1/4"-20 x 4 1/2")	4	01-6000-03	01-6000-03	01-6000-03	01-6000-03
5	Muffler Plate, Pro-Flo V™	1	04-3185-01	04-3185-01	04-3185-01	04-3185-01
6	<b>Gasket, Muffler Plate, Pro-Flo V™</b>	<b>1</b>	<b>04-3502-52</b>	<b>04-3502-52</b>	<b>04-3502-52</b>	<b>04-3502-52</b>
7	<b>Gasket, Air Valve, Pro-Flo V™</b>	<b>1</b>	<b>04-2620-52</b>	<b>04-2620-52</b>	<b>04-2620-52</b>	<b>04-2620-52</b>
8	Center Block Assembly, Pro-Flo V™	1	08-3127-01	08-3127-01	08-3127-01	08-3127-01
9	<b>Pilot Sleeve Assembly</b>	<b>1</b>	<b>08-3885-99</b>	<b>08-3885-99</b>	<b>08-3885-99</b>	<b>08-3885-99</b>
10	Pilot Spool Retaining O-Ring	2	04-2650-49-700	04-2650-49-700	04-2650-49-700	04-2650-49-700
11	<b>Shaft Seal</b>	<b>2</b>	<b>15-3210-55-225</b>	<b>15-3210-55-225</b>	<b>15-3210-55-225</b>	<b>15-3210-55-225</b>
12	Gasket, Center Block Pro-Flo V™	2	08-3536-52	08-3536-52	08-3536-52	08-3536-52
13	Air Chamber	2	08-3665-01	08-3665-01	08-3665-01	08-3665-01
14	Screw, SFCHC (3/8"-16 x 1 1/4")	8	08-6225-08	08-6225-08	08-6225-08	08-6225-08
15	Plate, Center Block Adapter	2	08-3081-01	08-3081-01	08-3081-01	08-3081-01
16	O-Ring	2	08-3025-52	08-3025-52	08-3025-52	08-3025-52
17	Shaft	1	08-3807-03	08-3807-03	08-3807-03	08-3807-03
18	Bumper	2	08-6902-23	08-6902-23	08-6902-23	08-6902-23
19	Piston, Inner	2	08-3705-08	08-3705-08	08-3705-08	08-3705-08
20	<b>Diaphragm, Flap Valve</b>	<b>2</b>	<b>*</b>	<b>*</b>	<b>*</b>	<b>*</b>
21	Piston, Outer	2	08-4555-08	08-4555-08	08-4555-08	08-4555-08
22	Chamber, Liquid	2	08-4985-01	08-4985-02	08-4985-01	08-4985-02
23	<b>Gasket, Seat</b>	<b>4</b>	<b>*</b>	<b>*</b>	<b>*</b>	<b>*</b>
24	Seat, Flap Valve	4	08-1150-08	08-1150-08	08-1150-08	08-1150-08
25	Gasket, Manifold	4	*	*	*	*
26	<b>Valve, Flap</b>	<b>4</b>	<b>*</b>	<b>*</b>	<b>*</b>	<b>*</b>
27	<b>Pad, Flap Valve Hinge</b>	<b>4</b>	<b>*</b>	<b>*</b>	<b>*</b>	<b>*</b>
28	Retainer, Flap Valve	4	08-1196-08	08-1196-08	08-1196-08	08-1196-08
29	Elbow, Inlet	2	08-5215-01	08-5215-02	08-5215-01	08-5215-02
30	Ring, Manifold Sealing	4	*	*	*	*
31	T-Section	2	08-5175-01	08-5175-02	08-5175-01-14	08-5175-02-14
32	Elbow, Discharge	2	08-5255-01	08-5255-02	08-5255-01	08-5255-02
33	Left - Hand Foot	2	08-5546-08	08-5546-08	08-5546-08	08-5546-08
34	Right - Hand Foot	2	08-5545-08	08-5545-08	08-5545-08	08-5545-08
35	Plate, Base	1	08-5550-08	08-5550-08	08-5550-08	08-5550-08
36	Stud, 1/4-20 x 1.50 Threaded	8	08-6162-08	08-6162-08	08-6162-08	08-6162-08
37	Stud, 3/8-16 x 2.50 Threaded	16	08-6161-08	08-6161-08	08-6161-08	08-6161-08
38	Screw, 3/8-16 x 1.56 HHC	4	08-6362-08	08-6362-08	08-6362-08	08-6362-08
39	<b>Screw, 3/8-16 x 2.18 HHC</b>	<b>8</b>	<b>08-6184-08</b>	<b>08-6184-08</b>	<b>08-6184-08</b>	<b>08-6184-08</b>
40	Screw, 7/16-14 x 1.18 HHC	8	08-6195-08	08-6195-08	08-6195-08	08-6195-08
41	Screw, 7/16-14 x 1.75 HHC	16	08-6194-08	08-6194-08	08-6194-08	08-6194-08
42	Nut, 3/8-16 Hex	20	02-6430-08	02-6430-08	02-6430-08	02-6430-08
43	Nut, 7/16-14 Hex	8	08-6427-08	08-6427-08	08-6427-08	08-6427-08
44	Washer, 3/8" Plain	28	15-6740-08-50	15-6740-08-50	15-6740-08-50	15-6740-08-50
45	Washer, 7/16" Plain	32	08-6734-08	08-6734-08	08-6734-08	08-6734-08
46	Nut, 1/4-20 Lock Hex	8	08-6477-08	08-6477-08	08-6477-08	08-6477-08
47	Screw, 5/8-11 x 1.50 HSFCHC	2	08-6092-08	08-6092-08	08-6092-08	08-6092-08
48	Muffler (not shown)	1	15-3510-99	15-3510-99	15-3510-99	15-3510-99
49	Shaft Bushing	2	15-3306-13	15-3306-13	15-3306-13	15-3306-13

\*Refer to Elastomer Options in Section 9  
¹Air Valve Assembly includes items 2 and 3.  
**All boldface items are primary wear parts.**

Shaded items included in PV810 Wetted Path  
[ 0677 ] Specialty Code = Horizontal Center Ported, NPT Threaded  
[ 0678 ] Specialty Code = Horizontal Center Ported, BSPT Threaded

**EXPLODED VIEW AND PARTS LISTING**

**PV810 ADVANCED METAL | Center Section Assembly | EXPLODED VIEW**

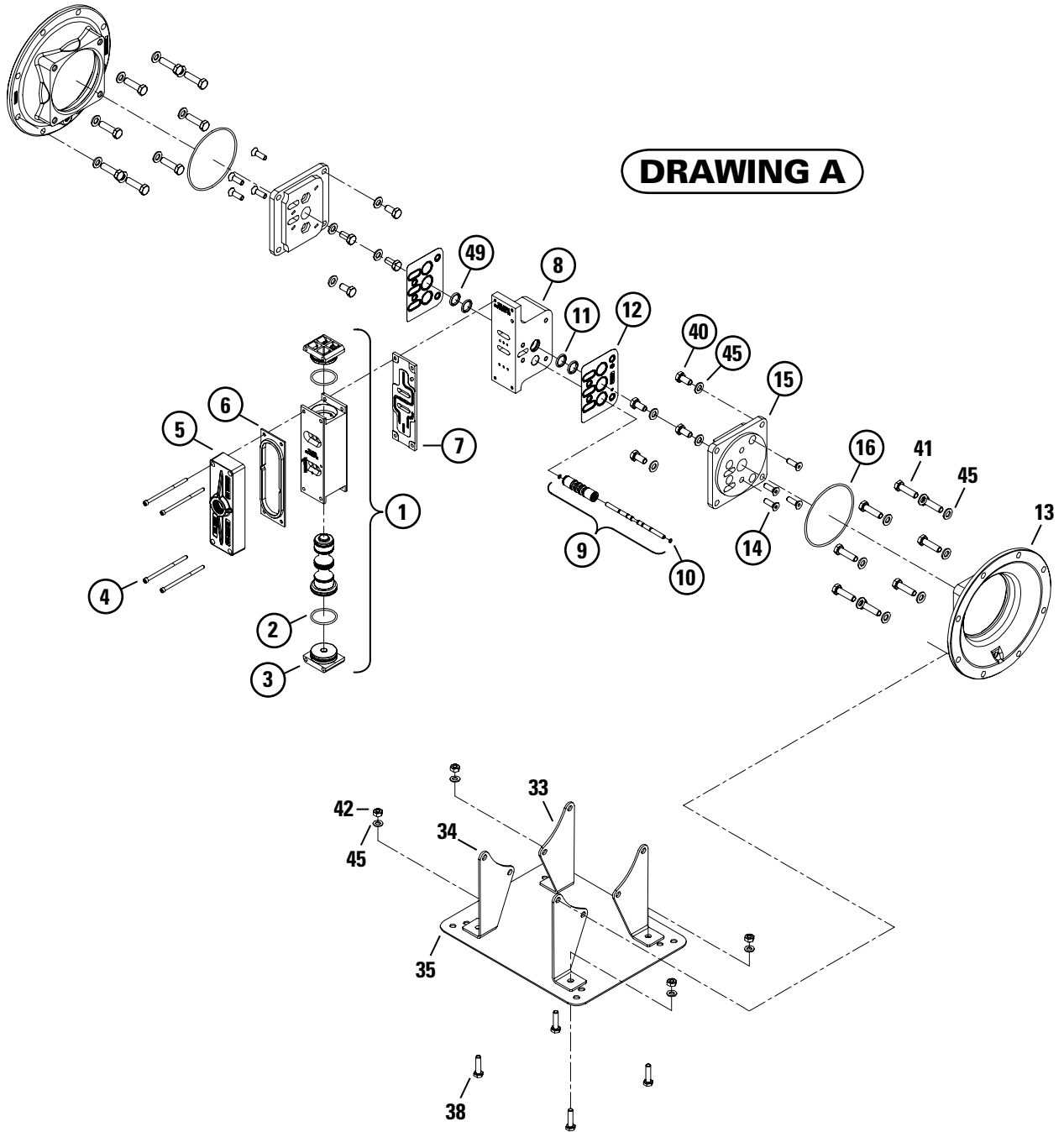

ALL CIRCLED PART IDENTIFIERS ARE INCLUDED IN CONVERSION KIT (See Section 9).

**EXPLODED VIEW AND PARTS LISTING**

**PV810 ADVANCED METAL | Center Section Assembly | PARTS LISTING**

DRAWING A	Item	Description	Qty.	PV810/ AMAAD/.../[677] P/N	PV810/ WMAAD/.../[677] P/N	PV810/ AMAAD/.../[678] P/N	PV810/ WMAAD/.../[678] P/N
	1	Pro-Flo V™ Assembly, Air Valve¹	1	04-2030-01	04-2030-01	04-2030-01	04-2030-01
2	O-Ring (-225), End Cap (1.859 x .139)	2	04-3290-52-700	04-3290-52-700	04-3290-52-700	04-3290-52-700	
3	End Cap	2	04-2340-01	04-2340-01	04-2340-01	04-2340-01	
4	Screw, SHC, Air Valve (1/4"-20 x 4 1/2")	4	01-6000-03	01-6000-03	01-6000-03	01-6000-03	
5	Muffler Plate, Pro-Flo V™	1	04-3185-01	04-3185-01	04-3185-01	04-3185-01	
6	<b>Gasket, Muffler Plate, Pro-Flo V™</b>	<b>1</b>	<b>04-3502-52</b>	<b>04-3502-52</b>	<b>04-3502-52</b>	<b>04-3502-52</b>	
7	<b>Gasket, Air Valve, Pro-Flo V™</b>	<b>1</b>	<b>04-2620-52</b>	<b>04-2620-52</b>	<b>04-2620-52</b>	<b>04-2620-52</b>	
8	Center Block Assembly, Pro-Flo V™	1	08-3127-01	08-3127-01	08-3127-01	08-3127-01	
9	<b>Pilot Sleeve Assembly</b>	<b>1</b>	<b>08-3885-99</b>	<b>08-3885-99</b>	<b>08-3885-99</b>	<b>08-3885-99</b>	
10	Pilot Spool Retaining O-Ring	2	04-2650-49-700	04-2650-49-700	04-2650-49-700	04-2650-49-700	
11	<b>Shaft Seal</b>	<b>2</b>	<b>15-3210-55-225</b>	<b>15-3210-55-225</b>	<b>15-3210-55-225</b>	<b>15-3210-55-225</b>	
12	Gasket, Center Block Pro-Flo V™	2	08-3536-52	08-3536-52	08-3536-52	08-3536-52	
13	Air Chamber	2	08-3665-01	08-3665-01	08-3665-01	08-3665-01	
14	Screw, SFCHC (3/8"-16 x 1 1/4")	8	08-6225-08	08-6225-08	08-6225-08	08-6225-08	
15	Plate, Center Block Adapter	2	08-3081-01	08-3081-01	08-3081-01	08-3081-01	
16	O-Ring	2	08-3025-52	08-3025-52	08-3025-52	08-3025-52	
17	Shaft	1	08-3807-03	08-3807-03	08-3807-03	08-3807-03	
18	Bumper	2	08-6902-23	08-6902-23	08-6902-23	08-6902-23	
19	Piston, Inner	2	08-3705-08	08-3705-08	08-3705-08	08-3705-08	
20	<b>Diaphragm, Flap Valve</b>	<b>2</b>	<b>*</b>	<b>*</b>	<b>*</b>	<b>*</b>	
21	Piston, Outer	2	08-4555-08	08-4555-08	08-4555-08	08-4555-08	
22	Chamber, Liquid	2	08-4985-01	08-4985-02	08-4985-01	08-4985-02	
23	<b>Gasket, Seat</b>	<b>4</b>	<b>*</b>	<b>*</b>	<b>*</b>	<b>*</b>	
24	Seat, Flap Valve	4	08-1150-08	08-1150-08	08-1150-08	08-1150-08	
25	Gasket, Manifold	4	*	*	*	*	
26	<b>Valve, Flap</b>	<b>4</b>	<b>*</b>	<b>*</b>	<b>*</b>	<b>*</b>	
27	<b>Pad, Flap Valve Hinge</b>	<b>4</b>	<b>*</b>	<b>*</b>	<b>*</b>	<b>*</b>	
28	Retainer, Flap Valve	4	08-1196-08	08-1196-08	08-1196-08	08-1196-08	
29	Elbow, Inlet	2	08-5215-01	08-5215-02	08-5215-01	08-5215-02	
30	Ring, Manifold Sealing	4	*	*	*	*	
31	T-Section	2	08-5175-01	08-5175-02	08-5175-01-14	08-5175-02-14	
32	Elbow, Discharge	2	08-5255-01	08-5255-02	08-5255-01	08-5255-02	
33	Left - Hand Foot	2	08-5546-08	08-5546-08	08-5546-08	08-5546-08	
34	Right - Hand Foot	2	08-5545-08	08-5545-08	08-5545-08	08-5545-08	
35	Plate, Base	1	08-5550-08	08-5550-08	08-5550-08	08-5550-08	
36	Stud, 1/4-20 x 1.50 Threaded	8	08-6162-08	08-6162-08	08-6162-08	08-6162-08	
37	Stud, 3/8-16 x 2.50 Threaded	16	08-6161-08	08-6161-08	08-6161-08	08-6161-08	
38	<b>Screw, 3/8-16 x 1.56 HHC</b>	<b>4</b>	<b>08-6362-08</b>	<b>08-6362-08</b>	<b>08-6362-08</b>	<b>08-6362-08</b>	
39	<b>Screw, 3/8-16 x 2.18 HHC</b>	<b>8</b>	<b>08-6184-08</b>	<b>08-6184-08</b>	<b>08-6184-08</b>	<b>08-6184-08</b>	
40	<b>Screw, 7/16-14 x 1.18 HHC</b>	<b>8</b>	<b>08-6195-08</b>	<b>08-6195-08</b>	<b>08-6195-08</b>	<b>08-6195-08</b>	
41	<b>Screw, 7/16-14 x 1.75 HHC</b>	<b>16</b>	<b>08-6194-08</b>	<b>08-6194-08</b>	<b>08-6194-08</b>	<b>08-6194-08</b>	
42	<b>Nut, 3/8-16 Hex</b>	<b>20</b>	<b>02-6430-08</b>	<b>02-6430-08</b>	<b>02-6430-08</b>	<b>02-6430-08</b>	
43	<b>Nut, 7/16-14 Hex</b>	<b>8</b>	<b>08-6427-08</b>	<b>08-6427-08</b>	<b>08-6427-08</b>	<b>08-6427-08</b>	
44	<b>Washer, 3/8" Plain</b>	<b>28</b>	<b>15-6740-08-50</b>	<b>15-6740-08-50</b>	<b>15-6740-08-50</b>	<b>15-6740-08-50</b>	
45	<b>Washer, 7/16" Plain</b>	<b>32</b>	<b>08-6734-08</b>	<b>08-6734-08</b>	<b>08-6734-08</b>	<b>08-6734-08</b>	
46	<b>Nut, 1/4-20 Lock Hex</b>	<b>8</b>	<b>08-6477-08</b>	<b>08-6477-08</b>	<b>08-6477-08</b>	<b>08-6477-08</b>	
47	<b>Screw, 5/8-11 x 1.50 HSFCHC</b>	<b>2</b>	<b>08-6092-08</b>	<b>08-6092-08</b>	<b>08-6092-08</b>	<b>08-6092-08</b>	
48	<b>Muffler (not shown)</b>	<b>1</b>	<b>15-3510-99</b>	<b>15-3510-99</b>	<b>15-3510-99</b>	<b>15-3510-99</b>	
49	<b>Shaft Bushing</b>	<b>2</b>	<b>15-3306-13</b>	<b>15-3306-13</b>	<b>15-3306-13</b>	<b>15-3306-13</b>	

\* Refer to Elastomer Options in Section 9  
¹Air Valve Assembly includes items 2 and 3.  
**All boldface items are primary wear parts.**

[ 0677 ] Specialty Code = Horizontal Center Ported, NPT Threaded  
[ 0678 ] Specialty Code = Horizontal Center Ported, BSPT Threaded

**EXPLODED VIEW AND PARTS LISTING**

**PV810 ADVANCED METAL**

**Flap Assemblies**

**EXPLODED VIEW**

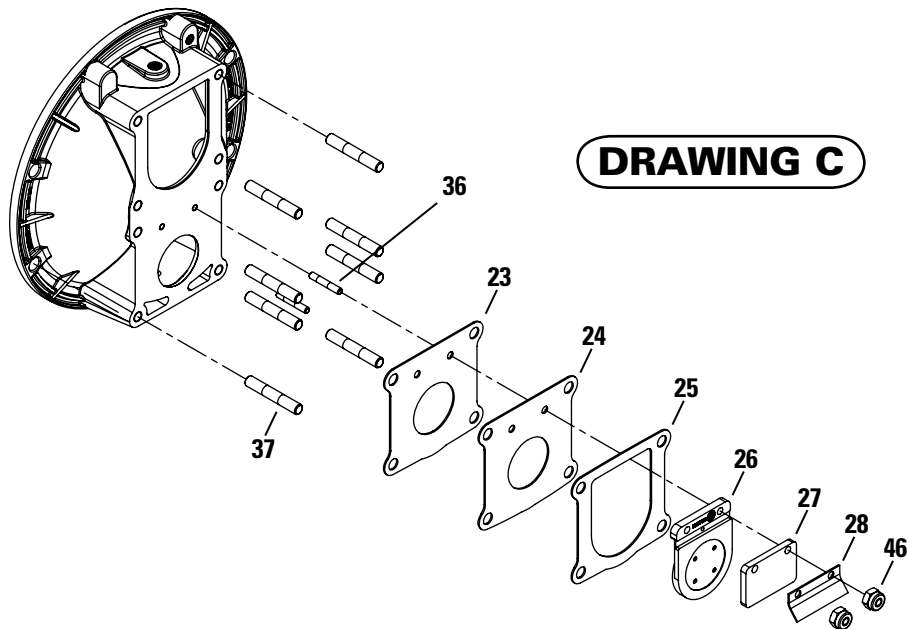
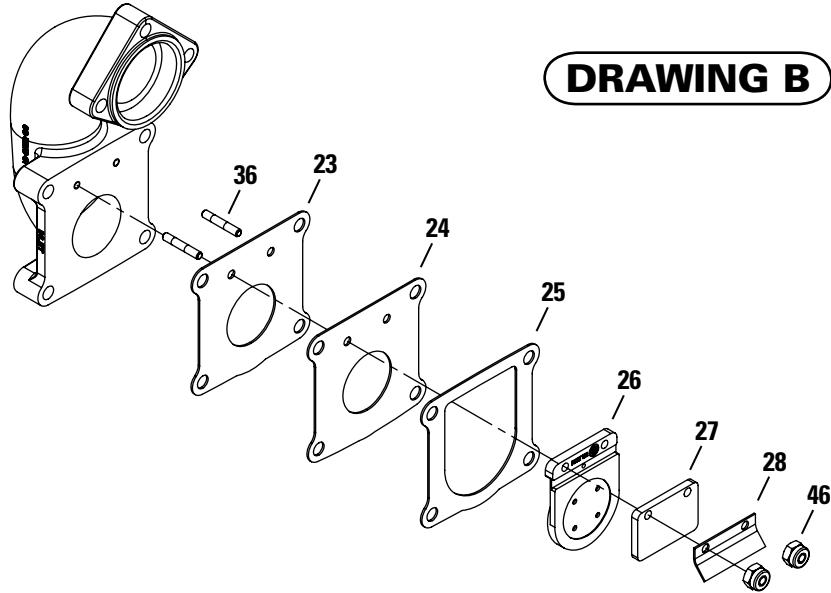

**EXPLODED VIEW AND PARTS LISTING**

**PV810 ADVANCED METAL**

**Flap Assemblies**

**PARTS LISTING**

Item	Description	Qty.	PV810/	PV810/	PV810/	PV810/
			AMAAD/.../[677] P/N	WMAAD/.../[677] P/N	AMAAD/.../[678] P/N	WMAAD/.../[678] P/N
1	Pro-Flo V™ Assembly, Air Valve <sup>1</sup>	1	04-2030-01	04-2030-01	04-2030-01	04-2030-01
2	O-Ring (-225), End Cap (1.859 x .139)	2	04-3290-52-700	04-3290-52-700	04-3290-52-700	04-3290-52-700
3	End Cap	2	04-2340-01	04-2340-01	04-2340-01	04-2340-01
4	Screw, SHC, Air Valve (1/4"-20 x 4 1/2")	4	01-6000-03	01-6000-03	01-6000-03	01-6000-03
5	Muffler Plate, Pro-Flo V™	1	04-3185-01	04-3185-01	04-3185-01	04-3185-01
6	<b>Gasket, Muffler Plate, Pro-Flo V™</b>	1	04-3502-52	04-3502-52	04-3502-52	04-3502-52
7	<b>Gasket, Air Valve, Pro-Flo V™</b>	1	04-2620-52	04-2620-52	04-2620-52	04-2620-52
8	Center Block Assembly, Pro-Flo V™	1	08-3127-01	08-3127-01	08-3127-01	08-3127-01
9	<b>Pilot Sleeve Assembly</b>	1	08-3885-99	08-3885-99	08-3885-99	08-3885-99
10	Pilot Spool Retaining O-Ring	2	04-2650-49-700	04-2650-49-700	04-2650-49-700	04-2650-49-700
11	Shaft Seal	2	15-3210-55-225	15-3210-55-225	15-3210-55-225	15-3210-55-225
12	Gasket, Center Block Pro-Flo V™	2	08-3536-52	08-3536-52	08-3536-52	08-3536-52
13	Air Chamber	2	08-3665-01	08-3665-01	08-3665-01	08-3665-01
14	Screw, SFCHC (3/8"-16 x 1 1/4")	8	08-6225-08	08-6225-08	08-6225-08	08-6225-08
15	Plate, Center Block Adapter	2	08-3081-01	08-3081-01	08-3081-01	08-3081-01
16	O-Ring	2	08-3025-52	08-3025-52	08-3025-52	08-3025-52
17	Shaft	1	08-3807-03	08-3807-03	08-3807-03	08-3807-03
18	Bumper	2	08-6902-23	08-6902-23	08-6902-23	08-6902-23
19	Piston, Inner	2	08-3705-08	08-3705-08	08-3705-08	08-3705-08
20	<b>Diaphragm, Flap Valve</b>	2	*	*	*	*
21	Piston, Outer	2	08-4555-08	08-4555-08	08-4555-08	08-4555-08
22	Chamber, Liquid	2	08-4985-01	08-4985-02	08-4985-01	08-4985-02
23	<b>Gasket, Seat</b>	4	*	*	*	*
24	Seat, Flap Valve	4	08-1150-08	08-1150-08	08-1150-08	08-1150-08
25	Gasket, Manifold	4	*	*	*	*
26	<b>Valve, Flap</b>	4	*	*	*	*
27	<b>Pad, Flap Valve Hinge</b>	4	*	*	*	*
28	Retainer, Flap Valve	4	08-1196-08	08-1196-08	08-1196-08	08-1196-08
29	Elbow, Inlet	2	08-5215-01	08-5215-02	08-5215-01	08-5215-02
30	Ring, Manifold Sealing	4	*	*	*	*
31	T-Section	2	08-5175-01	08-5175-02	08-5175-01-14	08-5175-02-14
32	Elbow, Discharge	2	08-5255-01	08-5255-02	08-5255-01	08-5255-02
33	Left - Hand Foot	2	08-5546-08	08-5546-08	08-5546-08	08-5546-08
34	Right - Hand Foot	2	08-5545-08	08-5545-08	08-5545-08	08-5545-08
35	Plate, Base	1	08-5550-08	08-5550-08	08-5550-08	08-5550-08
36	Stud, 1/4-20 x 1.50 Threaded	8	08-6162-08	08-6162-08	08-6162-08	08-6162-08
37	Stud, 3/8-16 x 2.50 Threaded	16	08-6161-08	08-6161-08	08-6161-08	08-6161-08
38	Screw, 3/8-16 x 1.56 HHC	4	08-6362-08	08-6362-08	08-6362-08	08-6362-08
39	Screw, 3/8-16 x 2.18 HHC	8	08-6184-08	08-6184-08	08-6184-08	08-6184-08
40	Screw, 7/16-14 x 1.18 HHC	8	08-6195-08	08-6195-08	08-6195-08	08-6195-08
41	Screw, 7/16-14 x 1.75 HHC	16	08-6194-08	08-6194-08	08-6194-08	08-6194-08
42	Nut, 3/8-16 Hex	20	02-6430-08	02-6430-08	02-6430-08	02-6430-08
43	Nut, 7/16-14 Hex	8	08-6427-08	08-6427-08	08-6427-08	08-6427-08
44	Washer, 3/8" Plain	28	15-6740-08-50	15-6740-08-50	15-6740-08-50	15-6740-08-50
45	Washer, 7/16" Plain	32	08-6734-08	08-6734-08	08-6734-08	08-6734-08
46	Nut, 1/4-20 Lock Hex	8	08-6477-08	08-6477-08	08-6477-08	08-6477-08
47	Screw, 5/8-11 x 1.50 HSFCHC	2	08-6092-08	08-6092-08	08-6092-08	08-6092-08
48	Muffler (not shown)	1	15-3510-99	15-3510-99	15-3510-99	15-3510-99
49	Shaft Bushing	2	15-3306-13	15-3306-13	15-3306-13	15-3306-13

\*Refer to Elastomer Options in Section 9  
<sup>1</sup>Air Valve Assembly includes items 2 and 3.  
**All boldface items are primary wear parts.**

[ 0678 ] Specialty Code = Horizontal Center Ported, BSPT Threaded  
 [ 0677 ] Specialty Code = Horizontal Center Ported, NPT Threaded

## ELASTOMER OPTIONS & CONVERSION KIT

### PV810 ADVANCED™ METAL ELASTOMER OPTIONS

MATERIAL	DIAPHRAGM, FLAP VALVE	GASKET, SEAT	GASKET, MANIFOLD	VALVE, FLAP	PAD, FLAP VALVE HINGE	RING, MANIFOLD SEALING
Neoprene	08-1012-51	08-1395-51	08-1401-51	08-1185-51	08-1195-51	08-1305-51
Buna-N	08-1012-52	08-1395-52	08-1401-52	08-1185-52	08-1195-52	08-1305-52

### CONVERSION KIT

Description	Part No.
Kit, PV810 Brahma Conversion*	08-9671-01

\*All circled items are included in PV810 Conversion Kit P/N 08-9671-01

**WARRANTY**

Each and every product manufactured by Wilden Pump and Engineering, LLC is built to meet the highest standards of quality. Every pump is functionally tested to insure integrity of operation.

Wilden Pump and Engineering, LLC warrants that pumps, accessories and parts manufactured or supplied by it to be free from defects in material and workmanship for a period of five (5) years from date of installation or six (6) years from date of manufacture, whichever comes first. Failure due to normal wear, misapplication, or abuse is, of course, excluded from this warranty.

Since the use of Wilden pumps and parts is beyond our control, we cannot guarantee the suitability of any pump or part for a particular application and Wilden Pump and Engineering, LLC shall not be liable for any consequential damage or expense arising from the use or misuse of its products on any application. Responsibility is limited solely to replacement or repair of defective Wilden pumps and parts.

All decisions as to the cause of failure are the sole determination of Wilden Pump and Engineering, LLC.

Prior approval must be obtained from Wilden for return of any items for warranty consideration and must be accompanied by the appropriate MSDS for the product(s) involved. A Return Goods Tag, obtained from an authorized Wilden distributor, must be included with the items which must be shipped freight prepaid.

The foregoing warranty is exclusive and in lieu of all other warranties expressed or implied (whether written or oral) including all implied warranties of merchantability and fitness for any particular purpose. No distributor or other person is authorized to assume any liability or obligation for Wilden Pump and Engineering, LLC other than expressly provided herein.

**PLEASE PRINT OR TYPE AND FAX TO WILDEN****PUMP INFORMATION**

Item # \_\_\_\_\_

Serial # \_\_\_\_\_

Company Where Purchased \_\_\_\_\_

**YOUR INFORMATION**

Company Name \_\_\_\_\_

Industry \_\_\_\_\_

Name \_\_\_\_\_

Title \_\_\_\_\_

Street Address \_\_\_\_\_

City \_\_\_\_\_

State \_\_\_\_\_

Postal Code \_\_\_\_\_

Country \_\_\_\_\_

Telephone \_\_\_\_\_

Fax \_\_\_\_\_

E-mail \_\_\_\_\_

Web Address \_\_\_\_\_

Number of pumps in facility? \_\_\_\_\_ Number of Wilden pumps? \_\_\_\_\_

Types of pumps in facility (check all that apply):  Diaphragm  Centrifugal  Gear  Submersible  Lobe Other \_\_\_\_\_

Media being pumped? \_\_\_\_\_

How did you hear of Wilden Pump?  Trade Journal  Trade Show  Internet/E-mail  Distributor Other \_\_\_\_\_**ONCE COMPLETE, FAX TO (909) 783-3440**

NOTE: WARRANTY VOID IF PAGE IS NOT FAXED TO WILDEN

WILDEN PUMP &amp; ENGINEERING, LLC