

P200

Advanced™ Series **PLASTIC** Pumps

EOM

Engineering
Operation &
Maintenance

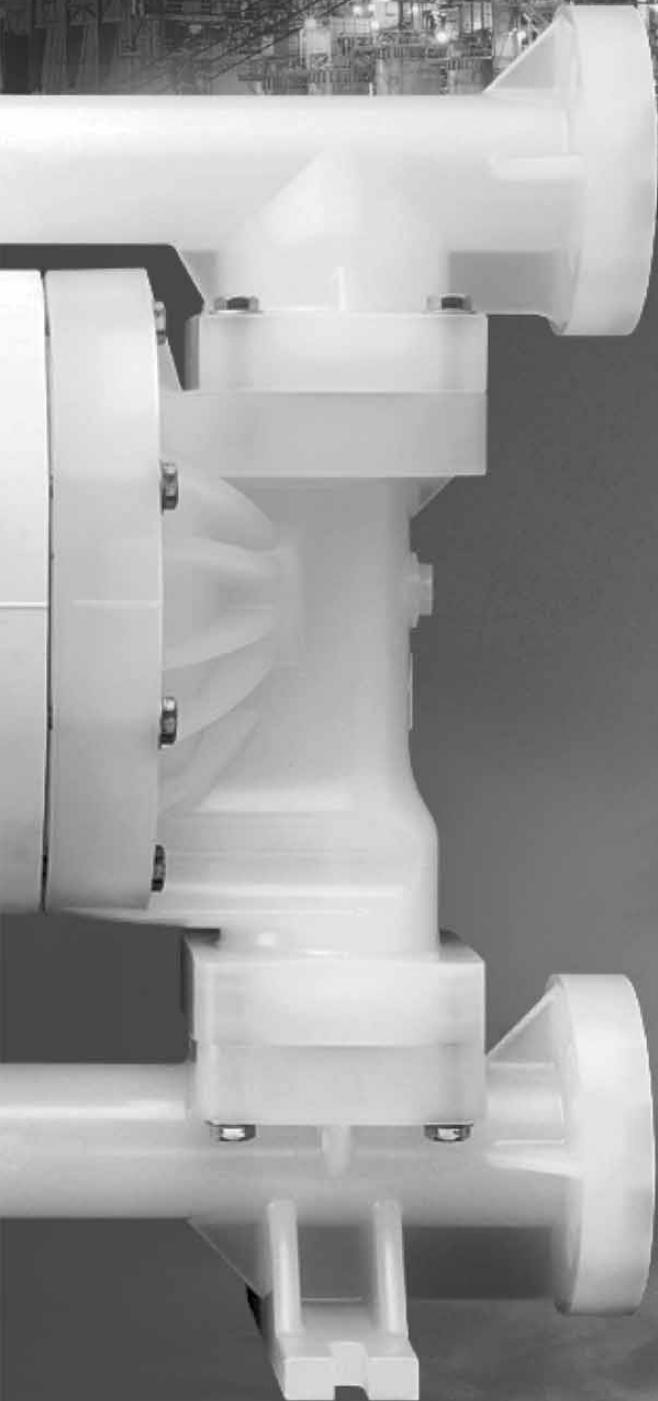

Advance your process

PRO-FLO[®]
PROGRESSIVE PUMP TECHNOLOGY

WILDEN[®]

A **DOVER** COMPANY

CE

WIL-11070-E-07
REPLACES WIL-11070-E-06

TABLE OF CONTENTS

	PAGE #
SECTION 1 – CAUTIONS	1
SECTION 2 – PUMP DESIGNATION SYSTEM	2
SECTION 3 – HOW IT WORKS (PUMP & AIR SYSTEMS)	3
SECTION 4 – DIMENSIONAL DRAWING	4
SECTION 5 – PERFORMANCE CURVES	
A. P200 ADVANCED™ PLASTIC Rubber-Fitted	5
B. P200 ADVANCED™ PLASTIC TPE-Fitted	5
C. P200 ADVANCED™ PLASTIC PTFE-Fitted	6
SECTION 6 – SUCTION LIFT CURVES & DATA	6
SECTION 7 – INSTALLATION AND OPERATION	
A. Installation.....	7
B. Operation & Maintenance	8
C. Troubleshooting.....	9
SECTION 8 – DIRECTIONS FOR DISASSEMBLY/REASSEMBLY	
A. P200 ADVANCED™ PLASTIC Wetted Path — Tools Required	10
B. Pro-Flo® Air Valve/Center Block — Disassembly, Cleaning, Inspection	13
C. Reassembly Hints & Tips, Torque Specs.	15
SECTION 9 – EXPLODED VIEW/PARTS LISTING	
A. P200 ADVANCED™ PLASTIC Rubber/TPE-Fitted	16
B. P200 ADVANCED™ PLASTIC PTFE-Fitted	18
SECTION 10 – ELASTOMER OPTIONS	20

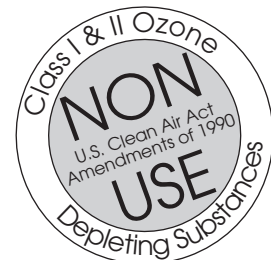

SECTION 1

CAUTIONS – READ FIRST!



TEMPERATURE LIMITS*

Wetted Path

Polypropylene (PP)	0°C to 79.4°C	32 °F to 175°F
Polyvinylidene fluoride (PVDF)	-12.2°C to 107.2°C	10 °F to 225°F
PFA	-28.9°C to 87.8°C	-20 °F to 190°F

Elastomers

Neoprene	-17.8°C to 93.3°C	0 °F to 200°F
Buna-N	-12.2°C to 82.2°C	10 °F to 180°F
EPDM	-51.1°C to 137.8°C	-60 °F to 280°F
Viton®	-40°C to 176.7°C	-40 °F to 350°F
Wil-Flex™	-40°C to 107.2°C	-40 °F to 225°F
Polyurethane	12.2°C to 65.6°C	10 °F to 150°F
Tetra-Flex™ PTFE w/Neoprene	4.4°C to 107.2°C	40 °F to 225°F
Tetra-Flex™ PTFE w/EPDM	-10°C to 137°C	14 °F to 280°F
Polytetrafluoroethylene (PTFE)	4.4°C to 104.4°C	40 °F to 220°F



*Elastomer choice may change temperature limits

CAUTION: When choosing pump materials, be sure to check the temperature limits for all wetted components. Example: Viton® has a maximum limit of 176.7°C (350°F) but polypropylene has a maximum limit of only 79.4°C (175°F).



CAUTION: Maximum temperature limits are based upon mechanical stress only. Certain chemicals will significantly reduce maximum safe operating temperatures. Consult engineering guide for chemical compatibility and temperature limits.



CAUTION: Always wear safety glasses when operating pump. If diaphragm rupture occurs, material being pumped may be forced out air exhaust.



WARNING: Prevention of static sparking — If static sparking occurs, fire or explosion could result. Proper grounding of pump, valves, and containers is critical when handling flammable fluids or whenever discharge of static electricity is a hazard.



NOTE: Do not exceed 5.2 bar (75 psig) air supply for PFA pumps.



CAUTION: Do not exceed 8.6 bar (125 psig) air supply on polypropylene and PVDF pumps.



CAUTION: Advanced™ series plastic pumps are made with plastic that is not UV stabilized. Direct sunlight for prolonged periods can cause deterioration of plastics.



CAUTION: Before any maintenance or repair is attempted, the compressed air line to the pump should be disconnected and all air pressure allowed to bleed from pump. Disconnect all intake, discharge and air lines. Drain the pump by turning it upside down and allowing any fluid to flow into a suitable container.



CAUTION: Blow out air line for 10 to 20 seconds before attaching to pump to make sure all pipe line debris is clear. Use an in-line air filter. A 5µ (micron) air filter is recommended.



NOTE: Tighten all bolts prior to installation. Fittings may loosen during transportation. See torque specifications on page 15.



NOTE: When installing polytetrafluoroethylene (PTFE) diaphragms, it is important to tighten outer pistons simultaneously (turning in opposite directions) to ensure tight fit.



CAUTION: Verify the chemical compatibility of the process and cleaning fluid to the pump's component materials in the Chemical Resistance Guide (see E4).



CAUTION: When removing the end cap using compressed air, the air valve end cap may come out with considerable force. Hand protection such as a padded glove or rag should be used to capture the end cap.



CAUTION: Do not over-tighten the air inlet reducer bushing. Additionally, too much torque on the muffler may damage the air valve muffler plate. Do not exceed 0.9 N-m (8 in-lbs).



NOTE: When reinstalling the outer pistons, apply two (2) drops of Loctite® 246 to the shaft internal threads before the diaphragm assembly.

SECTION 2

WILDEN PUMP DESIGNATION SYSTEM

P200 ADVANCED™ PLASTIC

25 mm (1") Pump
Maximum Flow Rate:
220 lpm (58 gpm)

**Maximum Operating
Pressure for PFA
is 5.2 bar (75 psig)**

LEGEND

P200 / XXXXX / XXX / XX / XXX / XXXX

MODEL

WETTED PARTS & OUTER PISTON

CENTER SECTION

AIR VALVE

DIAPHRAGMS

VALVE BALLS

O-RINGS

VALVE SEAT

SPECIALTY

CODE

(if applicable)

MATERIAL CODES

WETTED PARTS & OUTER PISTON

KK = PVDF / PVDF
PK = POLYPROPYLENE / PVDF
TT = PTFE / PTFE

CENTER SECTION

PP = POLYPROPYLENE

AIR VALVE

P = POLYPROPYLENE

DIAPHRAGMS

BNS = BUNA-N (Red Dot)
FSS = SANIFLEX™
[Hytrel® (Cream)]
EPS = EPDM (Blue Dot)
NES = NEOPRENE (Green Dot)
PUS = POLYURETHANE (Clear)
TEU = PTFE W/EPDM
BACK-UP (White)
TNU = PTFE W/NEOPRENE
BACK-UP (White)
TSU = PTFE W/SANIFLEX™
BACK-UP (White)
VTS = VITON® (White Dot)
WFS = WIL-FLEX™ [Santoprene®
(Orange Dot)]

VALVE BALL

BN = BUNA-N (Red Dot)
FS = SANIFLEX™
[Hytrel® (Cream)]
EP = EPDM (Blue Dot)
NE = NEOPRENE (Green Dot)
PU = POLYURETHANE (Brown)
TF = PTFE (White)
VT = VITON® (White Dot)
WF = WIL-FLEX™ [Santoprene®
(Orange Dot)]

VALVE SEAT

K = PVDF
P = POLYPROPYLENE
T = PTFE PFA

VALVE SEAT O-RING

BN = BUNA-N
PU = POLYURETHANE (Brown)
TV = PTFE ENCAP. VITON®
WF = WIL-FLEX™ (Santoprene®)

SPECIALTY CODES

0100 Wil-Gard II™ 110V
0102 Wil-Gard II™ sensor wires Only
0103 Wil-Gard II™ 220V
0206 PFA coated hardware,
Wil-Gard II™ sensor wires ONLY
0480 PCM I™ (Sensor & wires only)
0502 PFA coated hardware
0504 DIN flange
0506 DIN flange, PFA coated hardware
0603 PFA coated hardware, Wil-Gard II™ 110V
0604 DIN flange, Wil-Gard II™ 220V
0608 PFA coated hardware, Wil-Gard II™ 220V

Viton® is a registered trademark of DuPont Dow Elastomers.

SECTION 3

THE WILDEN PUMP — HOW IT WORKS

The Wilden diaphragm pump is an air-operated, positive displacement, self-priming pump. These drawings show the flow pattern through the pump upon its initial stroke. It is assumed the pump has no fluid in it prior to its initial stroke.

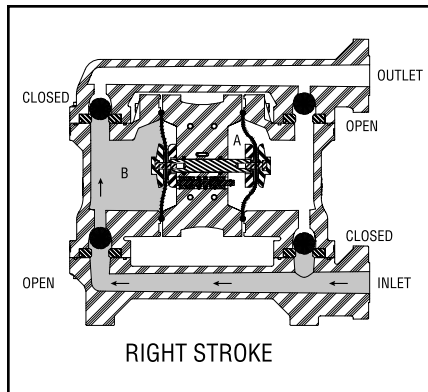

FIGURE 1 The air valve directs pressurized air to the back side of diaphragm A. The compressed air is applied directly to the liquid column separated by elastomeric diaphragms. The diaphragm acts as a separation membrane between the compressed air and liquid, balancing the load and removing mechanical stress from the diaphragm. The compressed air moves the diaphragm away from the center block of the pump. The opposite diaphragm is pulled in by the shaft connected to the pressurized diaphragm. Diaphragm B is on its suction stroke; air behind the diaphragm has been forced out to the atmosphere through the exhaust port of the pump. The movement of diaphragm B toward the center block of the pump creates a vacuum within chamber B. Atmospheric pressure forces fluid into the inlet manifold forcing the inlet valve ball off its seat. Liquid is free to move past the inlet valve ball and fill the liquid chamber (see shaded area).

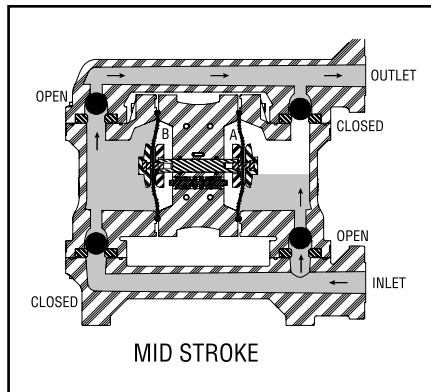

FIGURE 2 When the pressurized diaphragm, diaphragm A, reaches the limit of its discharge stroke, the air valve redirects pressurized air to the back side of diaphragm B. The pressurized air forces diaphragm B away from the center block while pulling diaphragm A to the center block. Diaphragm B is now on its discharge stroke. Diaphragm B forces the inlet valve ball onto its seat due to the hydraulic forces developed in the liquid chamber and manifold of the pump. These same hydraulic forces lift the discharge valve ball off its seat, while the opposite discharge valve ball is forced onto its seat, forcing fluid to flow through the pump discharge. The movement of diaphragm A toward the center block of the pump creates a vacuum within liquid chamber A. Atmospheric pressure forces fluid into the inlet manifold of the pump. The inlet valve ball is forced off its seat allowing the fluid being pumped to fill the liquid chamber.

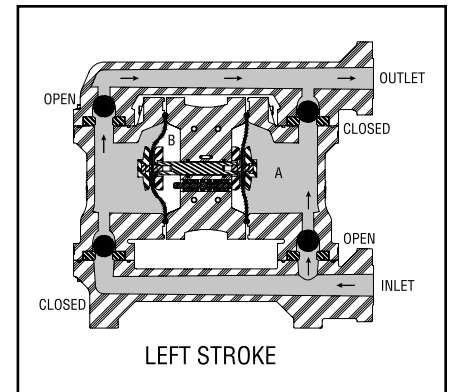

FIGURE 3 At completion of the stroke, the air valve again redirects air to the back side of diaphragm A, which starts diaphragm B on its exhaust stroke. As the pump reaches its original starting point, each diaphragm has gone through one exhaust and one discharge stroke. This constitutes one complete pumping cycle. The pump may take several cycles to completely prime depending on the conditions of the application.

PRO-FLO® AIR DISTRIBUTION SYSTEM OPERATION — HOW IT WORKS

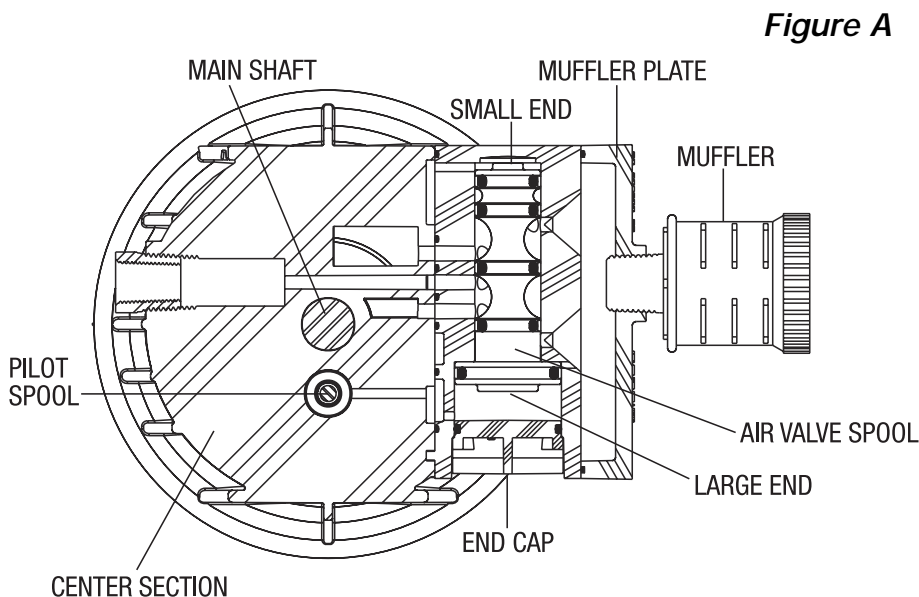
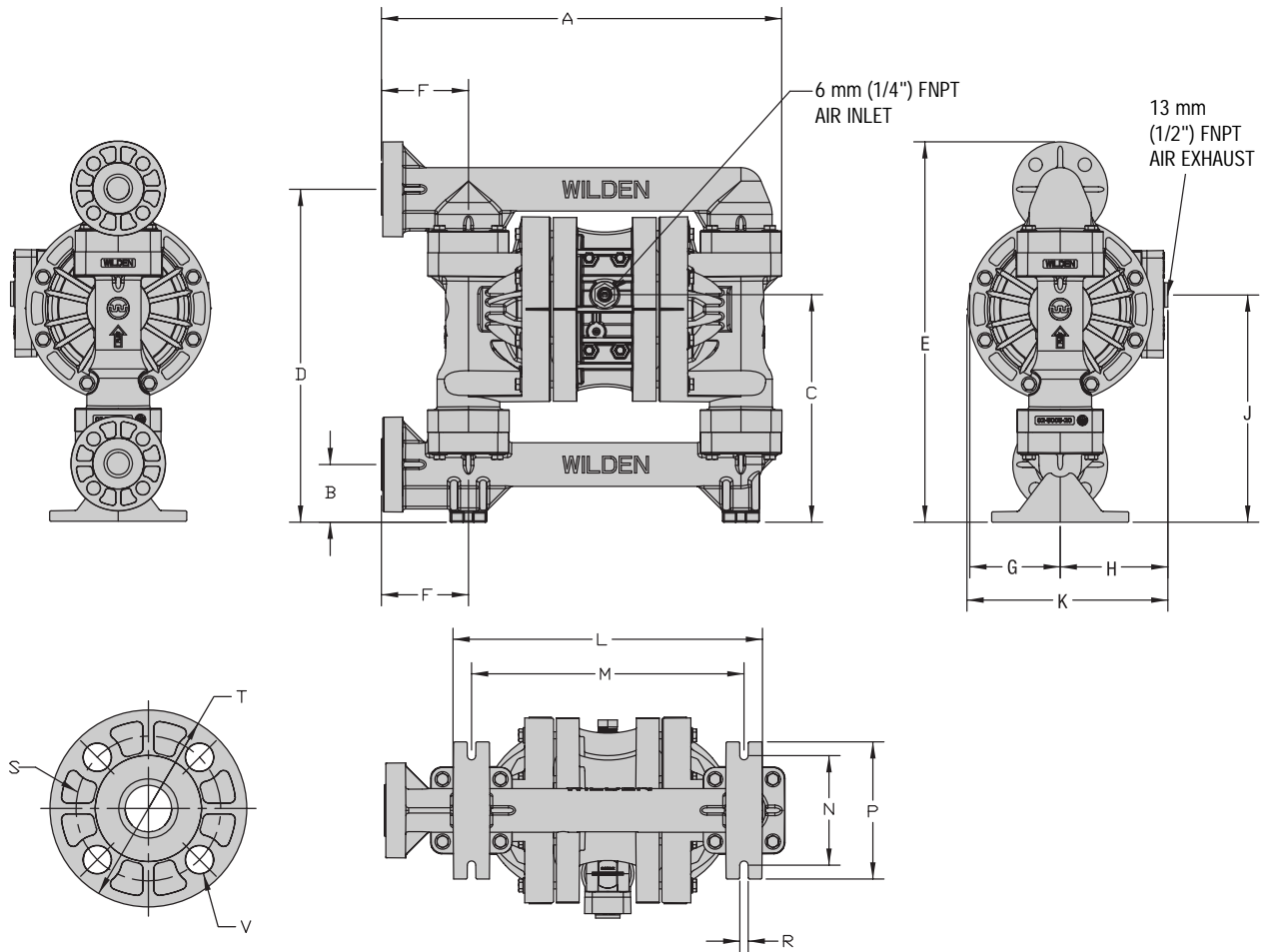

Figure A

The Pro-Flo® patented air distribution system incorporates three moving parts: the air valve spool, the pilot spool, and the main shaft/diaphragm assembly. The heart of the system is the air valve spool and air valve. As shown in Figure A, this valve design incorporates an unbalanced spool. The smaller end of the spool is pressurized continuously, while the large end is alternately pressurized then exhausted to move the spool. The spool directs pressurized air to one air chamber while exhausting the other. The air causes the main shaft/diaphragm assembly to shift to one side — discharging liquid on that side and pulling liquid in on the other side. When the shaft reaches the end of its stroke, the inner piston actuates the pilot spool, which pressurizes and exhausts the large end of the air valve spool. The repositioning of the air valve spool routes the air to the other air chamber.

SECTION 4

DIMENSIONAL DRAWING P200 ADVANCED™ PLASTIC



DIMENSIONS

ITEM	METRIC (mm)	STANDARD (inch)
A	457	18.0
B	66	2.6
C	259	10.2
D	381	15.0
E	434	17.1
F	99	3.9
G	104	4.1
H	122	4.8
J	259	10.2
K	231	9.1
L	353	13.9
M	310	12.2
N	124	4.9
P	157	6.2
R	10	0.4
DIN FLANGE		
S	85 DIA.	3.3 DIA.
T	115 DIA.	4.5 DIA.
U	14 DIA.	0.6 DIA.
ANSI FLANGE		
S	79 DIA.	3.1 DIA.
T	108 DIA.	4.3 DIA.
U	16 DIA.	0.6 DIA.

SECTION 7A

INSTALLATION

The Pro-Flo® model **P200 Advanced™** plastic has a 25 mm (1") inlet and 25 mm (1") outlet and is designed for flows to 220 lpm (58 gpm). The **P200 Advanced™** plastic pump is manufactured with wetted parts of pure, unpigmented Polypropylene or PVDF. The **P200 Advanced™** plastic pump is constructed with a glass fiber filled PP center section. A variety of diaphragms and o-rings are available to satisfy temperature, chemical compatibility, abrasion, and flex concerns.

The suction pipe size should be at least 25 mm (1") diameter or larger if highly viscous material is being pumped. The suction hose must be non-collapsible, reinforced type as the **P200 Advanced™** plastic pump is capable of pulling a high vacuum. Discharge piping should be at least 25 mm (1"); larger diameter can be used to reduce friction losses. It is critical that all fittings and connections are airtight or a reduction or loss of pump suction capability will result.

INSTALLATION: Months of careful planning, study, and selection efforts can result in unsatisfactory pump performance if installation details are left to chance.

Premature failure and long term dissatisfaction can be avoided if reasonable care is exercised throughout the installation process.

LOCATION: Noise, safety, and other logistical factors usually dictate where equipment should be situated on the production floor. Multiple installations with conflicting requirements can result in congestion of utility areas, leaving few choices for additional pumps.

Within the framework of these and other existing conditions, every pump should be located in such a way that five key factors are balanced against each other to maximum advantage.

ACCESS: First, the location should be accessible. If it is easy to reach the pump, maintenance personnel will have an easier time carrying out routine inspections and adjustments. Should major repairs become necessary, ease of access can play a key role in speeding the repair process and reducing total downtime.

AIR SUPPLY: Every pump location should have an air line large enough to supply the volume of air necessary to achieve the desired pumping rate (see Section 5). Do not exceed 5.2 bar (75 psig) air supply for PFA pumps. Use air pressure up to a maximum of 8.6 bar (125 psig) for polypropylene and PVDF pumps depending on pumping requirements.

For best results, the pumps should use a 5 μ (micron) air filter, needle valve and regulator. The use of an air filter before the pump will insure that the majority of any pipeline contaminants will be eliminated.

SOLENOID OPERATION: When operation is controlled by a solenoid valve in the air line, three-way valves should be used, thus allowing trapped air to bleed off and improving pump performance. Pumping volume can be set by counting the number of strokes per minute and multiplying by displacement per stroke.

SOUND: Sound levels are reduced using the standard Wilden muffler element. Other mufflers can be used, but usually reduce pump performance.

ELEVATION: Selecting a site that is well within the pump's dynamic lift capability will assure that loss-of-prime troubles will be eliminated. In addition, pump efficiency can be adversely affected if proper attention is not given to site location.

PIPING: Final determination of the pump site should not be made until the piping problems of each possible location have been evaluated. The impact of current and future installations should be considered ahead of time to make sure that inadvertent restrictions are not created for any remaining sites.

The best choice possible will be a site involving the shortest and straightest hook-up of suction and discharge piping. Unnecessary elbows, bends, and fittings should be avoided. Pipe sizes should be selected to keep friction losses within practical limits. All piping should be supported independently of the pump. In addition, the piping should be aligned to avoid placing stresses on the pump fittings.

Flexible hose can be installed to aid in absorbing the forces created by the natural reciprocating action of the pump. If the pump is to be bolted down to a solid location, a mounting pad placed between the pump and the foundation will assist in minimizing pump vibration. Flexible connections between the pump and rigid piping will also assist in minimizing pump vibration. If quick-closing valves are installed at any point in the discharge system, or if pulsation within a system becomes a problem, a surge suppressor should be installed to protect the pump, piping and gauges from surges and water hammer.

The P200 Advanced™ plastic Pro-Flo® equipped pump can be installed in submersible applications only when both the wetted and non-wetted portions are compatible with the material being pumped. If the pump is to be used in a submersible application, a hose should be attached to the air and pilot spool exhaust ports of the pump. These should then be piped above the liquid level. The exhaust area for the pilot spool is designed to be tapped for a 1/8" NPT fitting.

When pumps are installed in applications involving flooded suction or suction head pressures, a gate valve should be installed in the suction line to permit closing of the line for pump service.

If the pump is to be used in a self-priming application, be sure that all connections are airtight and that the suction-lift is within the ability of the model. Note: Materials of construction and elastomer material have an effect on suction lift parameters. Please consult Wilden distributors for specifics.

Pumps in service with a positive suction head are most efficient when inlet pressure is limited to 0.5–0.7 bar (7–10 psig). Premature diaphragm failure may occur if positive suction is 0.7 bar (10 psig) and higher.

THE MODEL P200 ADVANCED™ PLASTIC WILL PASS 4.76 mm (3/16") SOLIDS. WHENEVER THE POSSIBILITY EXISTS THAT LARGER SOLID OBJECTS MAY BE SUCKED INTO THE PUMP, A STRAINER SHOULD BE USED ON THE SUCTION LINE.

CAUTION: DO NOT EXCEED 5.2 BAR (75 PSIG) AIR SUPPLY FOR PFA PUMPS. DO NOT EXCEED 8.6 BAR (125 PSIG) AIR SUPPLY PRESSURE FOR POLYPROPYLENE AND PVDF PUMPS.

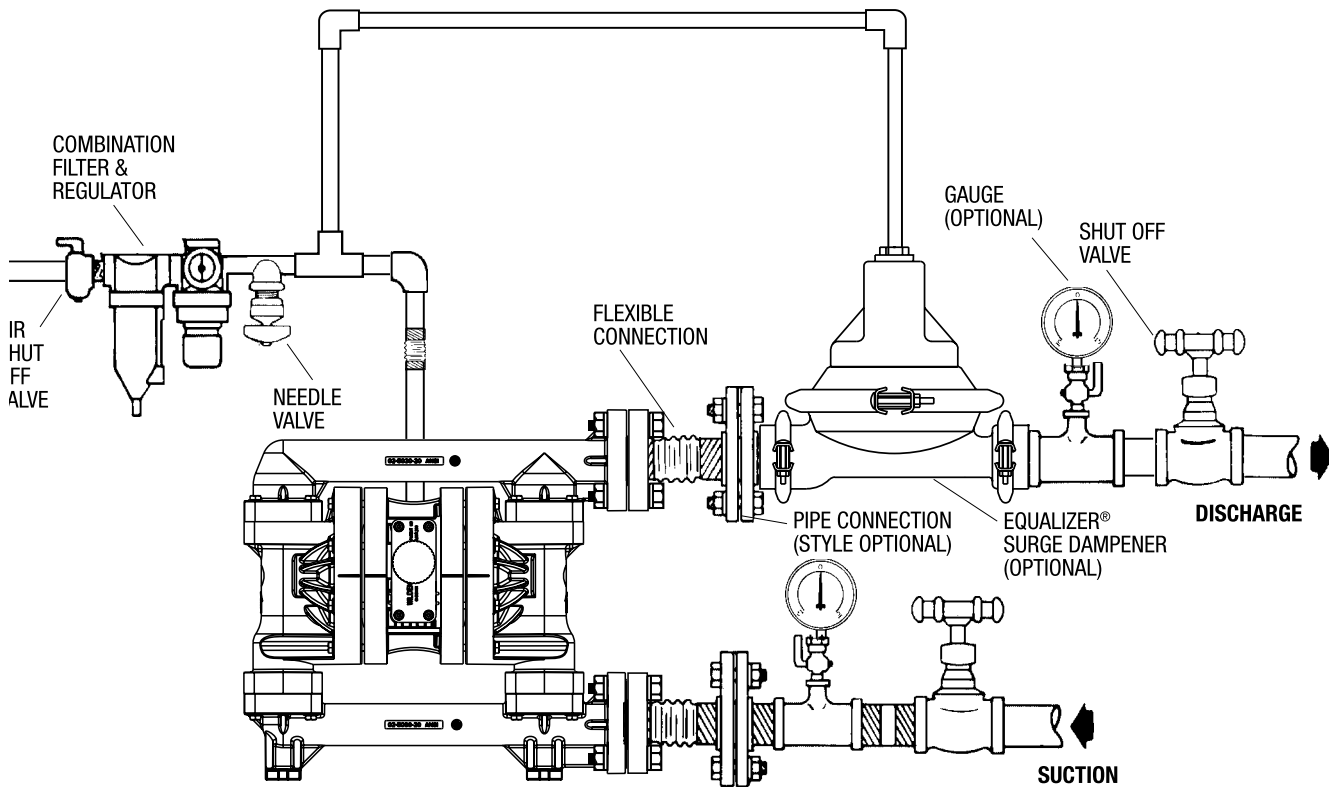

AIR-OPERATED PUMPS: To stop the pump from operating in an emergency situation, simply close the "shut-off" valve (user supplied) installed in the air supply line. A properly functioning valve will stop the air supply to the pump, therefore stopping output. This shut-off valve should be located far enough away from the pumping equipment such that it can be reached safely in an emergency situation.

NOTE: In the event of a power failure, the shutoff valve should be closed, if the restarting of the pump is not desirable once power is regained.

SECTION 7B

SUGGESTED OPERATION AND MAINTENANCE INSTRUCTIONS

OPERATION: Pump discharge rate can be controlled by limiting the volume and/or pressure of the air supply to the pump (preferred method). An air regulator is used to regulate air pressure. A needle valve is used to regulate volume. Pump discharge rate can also be controlled by throttling the pump discharge by partially closing a valve in the discharge line of the pump. This action increases friction loss, which reduces flow rate. This is useful when the need exists to control the pump from a remote location. When the pump discharge pressure equals or exceeds the air supply pressure, the pump will stop; no bypass or pressure relief valve is needed, and pump damage will not occur. The pump has been "deadheaded." It can be restarted by reducing the fluid discharge pressure, or increasing the air inlet pressure. The Wilden P200 Advanced™ plastic pump runs solely on compressed air and does not generate heat, therefore your process fluid temperature will not be affected.

RECORDS: When service is required, a record should be made of all necessary repairs and replacements. Over a period of time, such records can become a valuable tool for predicting and preventing future maintenance problems and unscheduled downtime. In addition, accurate records make it possible to identify pumps that are poorly suited to their applications.

MAINTENANCE AND INSPECTIONS: Since each application is unique, maintenance schedules may be different for every pump. Frequency of use, line pressure, viscosity and abrasiveness of process fluid all affect the parts life of a Wilden pump. Periodic inspections have been found to offer the best means for preventing unscheduled pump downtime. Personnel familiar with the pump's construction and service should be informed of any abnormalities that are detected during operation.

SECTION 7C

TROUBLESHOOTING

Pump will not run or runs slowly.

1. Ensure that the air inlet pressure is at least 0.35 bar (5 psig) above startup pressure and that the differential pressure (the difference between air inlet and liquid discharge pressures) is not less than 0.7 bar (10 psig).
2. Check air inlet filter for debris (see recommended installation).
3. Check for extreme air leakage (blow by) which would indicate worn seals/bores in the air valve, pilot spool, main shaft.
4. Disassemble pump and check for obstructions in the air passageways or objects which would obstruct the movement of internal parts.
5. Check for sticking ball check valves. If material being pumped is not compatible with pump elastomers, swelling may occur. Replace ball check valves and seals with proper elastomers. In addition, valve balls become smaller as the wear. This may cause them to become stuck in the seats. In this case, replace balls and seats.
6. Check for broken inner piston, which will prevent the air valve spool from shifting.
7. Remove plug from pilot spool exhaust, check pilot spool exhaust for blockage.

Pump runs but little or no product flows.

1. Check for pump cavitation; slow pump speed down to allow thick material to flow into liquid chambers.
2. Verify that vacuum required to lift liquid is not greater than the vapor pressure of the material being pumped (cavitation).

3. Check for sticking ball check valves. If material being pumped is not compatible with pump elastomers, swelling may occur. Replace ball check valves and seals with proper elastomers. In addition, valve balls become smaller as the wear. This may cause them to become stuck in the seats. In this case, replace balls and seats.

Pump air valve freezes.

1. Check for excessive moisture in compressed air. Install either a dryer, or hot air generator for compressed air. Alternatively, a coalescing filter may be used to remove the water from the compressed air in some applications.

Air bubbles in pump discharge.

1. Check for ruptured diaphragm.
2. Check tightness of outer pistons.
3. Check torque of bolts and integrity of o-rings and seals, especially at intake manifold.
4. Ensure pipe connections are airtight.

Product comes out air exhaust.

1. Check for diaphragm rupture.
2. Check tightness of outer pistons to shaft.

SECTION 8A

P200 ADVANCED™ PLASTIC DIRECTIONS FOR DISASSEMBLY/REASSEMBLY

CAUTION: Before any maintenance or repair is attempted, the compressed air line to the pump should be disconnected and all air pressure allowed to bleed from the pump. Disconnect all intake, discharge, and air lines. Drain the pump by turning it upside down and allowing any fluid to flow into a suitable container. Be aware of any hazardous effects of contact with your process fluid.

TOOLS REQUIRED:

13 mm (1/2") Box Wrench
2 - 25 mm (1") Sockets or Adjustable Wrench
Adjustable Wrench
Vise equipped with soft jaws (such as plywood, plastic or other suitable material)

NOTE: The model used for these instructions incorporates PTFE diaphragms and balls. Models with rubber diaphragms and balls are the same except where noted.

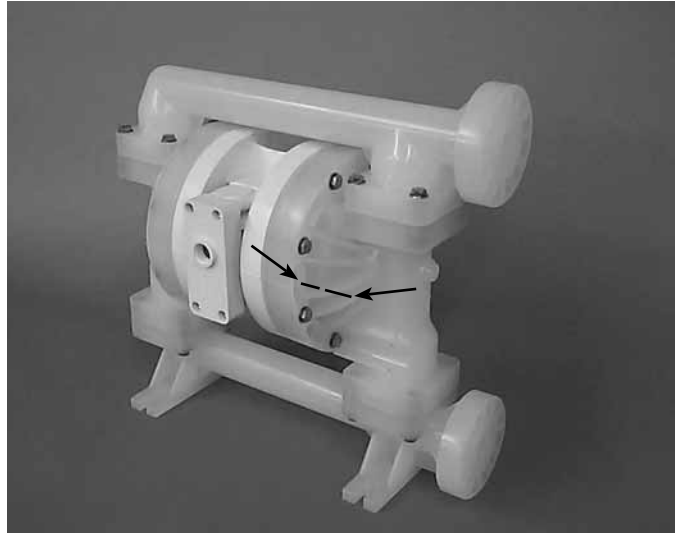

DISASSEMBLY:

Figure 1

Step 1.

Please see pre-molded alignment marks on the liquid chamber and center section.

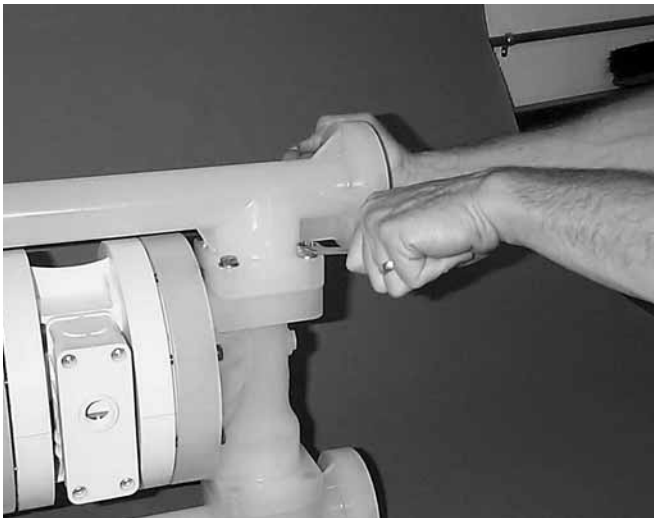

Step 2.

Figure 2

Using the 13 mm (1/2") box wrench, loosen the discharge manifold from the liquid chambers.

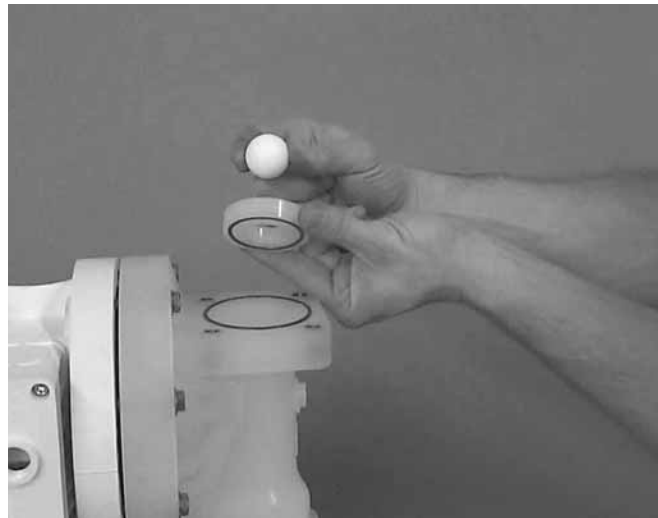

Step 3.

Figure 3

Remove the discharge manifold to expose the valve balls, valve seats and valve seat o-rings.

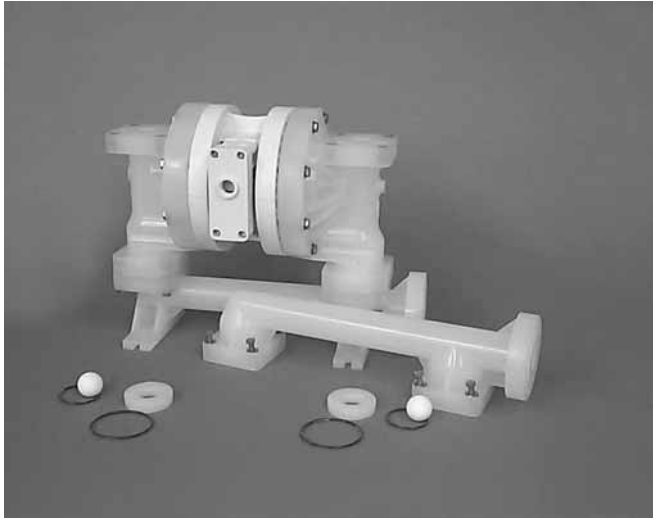

Step 4. *Figure 4*

Remove the discharge valve balls, seats and valve seat o-rings from the discharge manifold and liquid chamber, inspect for nicks, gouges, chemical attack or abrasive wear. Replace worn parts with genuine Wilden parts for reliable performance.

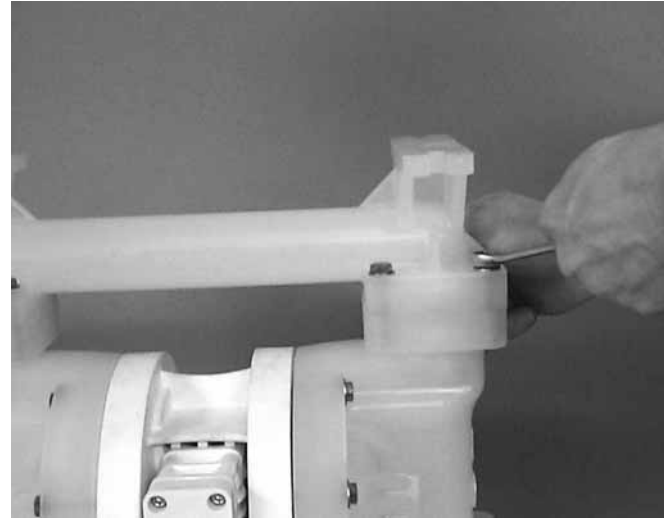

Step 5. *Figure 5*

Using a 13 mm (1/2") box wrench, remove the inlet manifold.

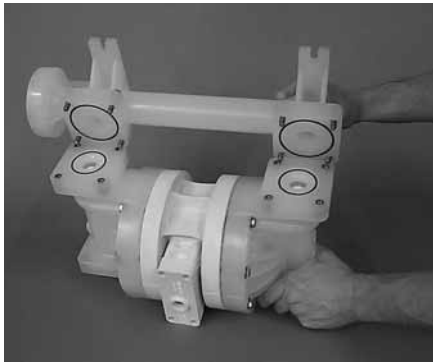

Step 6. *Figure 6*

Remove the inlet valve balls, seats and valve seat o-rings from the liquid chamber and discharge manifold, inspect for nicks, gouges, chemical attack or abrasive wear. Replace worn parts with genuine Wilden parts for reliable performance.



Step 7. *Figure 7*

With a 13 mm (1/2") box wrench, remove the liquid chambers from the center section.

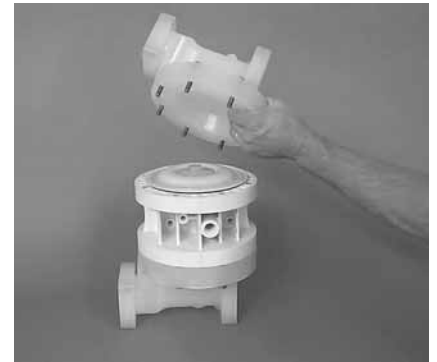

Step 8. *Figure 8*

The liquid chamber should be removed to expose the diaphragm and outer piston. Rotate center section and remove the opposite liquid chamber.

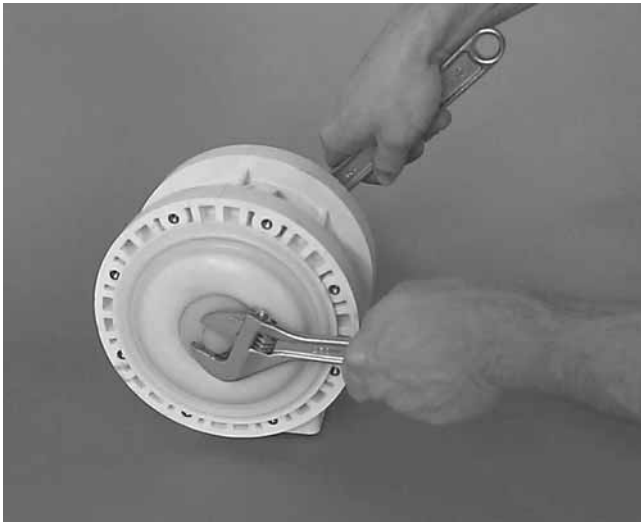

Step 9. *Figure 9*
Using two crescent wrenches or 25 mm (1") sockets, remove diaphragm assembly from center section assembly.



Step 10. *Figure 10*
After loosening and removing the outer piston the diaphragm assembly can be disassembled.



Step 11. *Figure 11*
To remove the remaining diaphragm assembly from the shaft, secure shaft with soft jaws (a vise fitted with plywood or other suitable material) to ensure shaft is not nicked, scratched, or gouged. Using an adjustable wrench, remove diaphragm assembly from shaft. Inspect all parts for wear and replace with genuine Wilden parts if necessary.



Step 12. *Figure 12*
Inspect diaphragms, outer and inner pistons for signs of wear. Replace with genuine Wilden parts if necessary.

SECTION 8B

PRO-FLO® AIR VALVE/CENTER SECTION DISASSEMBLY, CLEANING, INSPECTION

AIR VALVE DISASSEMBLY:

CAUTION: Before any maintenance or repair is attempted, the compressed air line to the pump should be disconnected and all air pressure allowed to bleed from the pump. Disconnect all intake, discharge, and air lines. Drain the pump by turning it upside down and allowing any fluid to flow into a suitable container. Be aware of hazardous effects of contact with your process fluid.

The Wilden P200 Advanced™ Plastic Pump utilizes a revolutionary Pro-Flo® air distribution system. A 6 mm (1/4") air inlet connects the air supply to the center section. Proprietary composite seals reduce the coefficient of friction and allow the P200 to run lube-free. Constructed of polypropylene, the Pro-Flo® air distribution system is designed to perform in on/off, non-freezing, non-stalling, tough duty applications.

TOOLS REQUIRED:

3/16" Allen Wrench
Snap Ring Pliers
O-Ring Pick

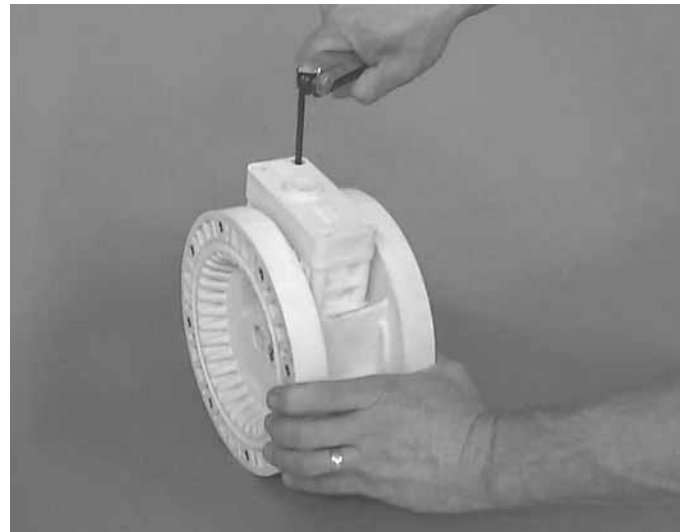

Step 1.

Figure 1

Loosen the air valve bolts utilizing a 3/16" Allen wrench.

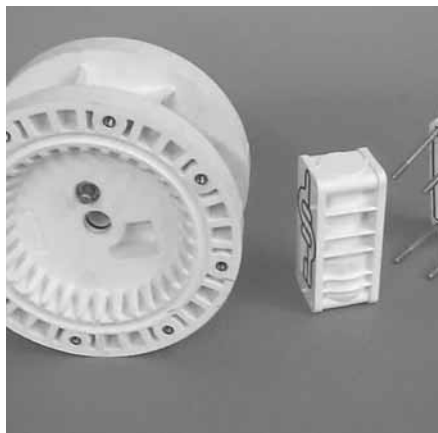

Step 2.

Figure 2

Remove muffer plate and air valve bolts from air valve assembly exposing muffer gasket for inspection. Replace if necessary.



Step 3.

Figure 3

Lift away air valve assembly and remove air valve gasket for inspection. Replace if necessary.



Step 4.

Figure 4

Remove air valve end cap to expose air valve spool by simply lifting up on end cap once air valve bolts are removed.



Step 5. *Figure 5*

Remove air valve spool from air valve body by threading one air valve bolt into the end of the spool and gently sliding the spool out of the air valve body. Inspect seals for signs of wear and replace entire assembly if necessary. Use caution when handling air valve spool to prevent damaging seals.

NOTE: Seals should not be removed from assembly. Seals are not sold separately.

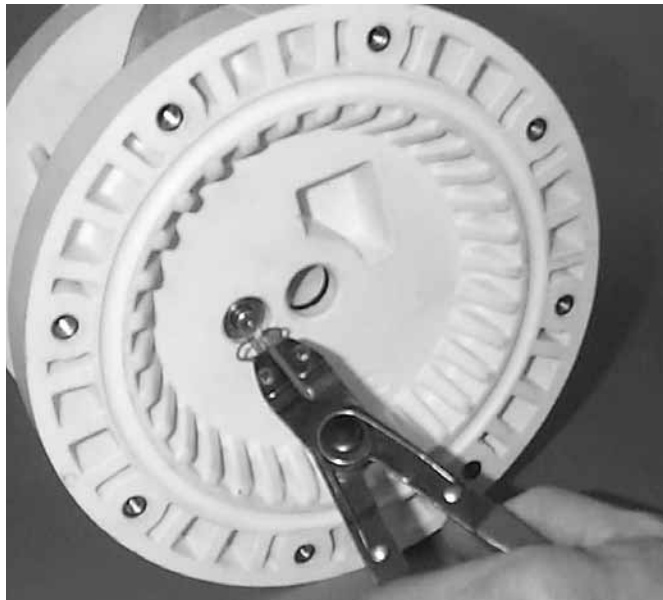

Step 6. *Figure 6*

Remove pilot spool sleeve retaining snap ring on both sides of center section with snap ring pliers.

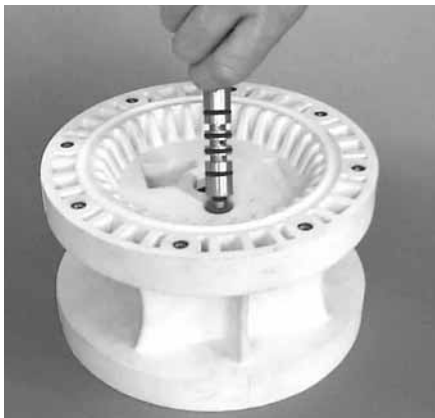

Step 7. *Figure 7*

Remove pilot spool sleeve from center section.



Step 8. *Figure 8*

With o-ring pick, gently remove the o-ring from the opposite side of the "center hole" cut on the spool. Gently remove the pilot spool from sleeve and inspect for nicks or gouges and other signs of wear. Replace pilot sleeve assembly or outer sleeve o-rings if necessary. During re-assembly never insert the pilot spool into the sleeve with the "center cut" side first, this end incorporates the urethane o-ring and will be damaged as it slides over the ports cut in the sleeve.

NOTE: Seals should not be removed from pilot spool. Seals are not sold separately.



Step 9. *Figure 9*

Check center section Glyd™ rings for signs of wear. If necessary, remove Glyd™ rings with o-ring pick and replace.

SECTION 8C

REASSEMBLY HINTS & TIPS

ASSEMBLY:

Upon performing applicable maintenance to the air distribution system, the pump can now be reassembled. Please refer to the disassembly instructions for photos and parts placement. To reassemble the pump, follow the disassembly instructions in reverse order. The air distribution system needs to be assembled first, then the diaphragms and finally the wetted path. Please find the applicable torque specifications on this page. The following tips will assist in the assembly process.

- Clean the inside of the center section shaft bore to ensure no damage is done to new seals.
- Stainless bolts should be lubed to reduce the possibility of seizing during tightening.
- Be sure to tighten outer pistons simultaneously on PTFE-fitted pumps to ensure proper torque values.
- Apply two (2) drops of Loctite® 246 to the shaft internal threads before the diaphragm assembly.
- Concave side of disc spring in diaphragm assembly faces **toward** inner piston.

MAXIMUM TORQUE SPECIFICATIONS

Part Description	Torque
Pro-Flo® Air Valve	3.1 N•m (27 in-lbs)
Air Inlet Reducer Bushing	0.9 N•m (8 in-lbs)
Outer Piston (rubber, TPE, & PTFE diaphragm fitted)	27.1 N•m (20 ft-lbs)
Top & Bottom Manifolds (Poly & PVDF)	5.6 N•m (50 in-lbs)
Liquid Chamber (Poly & PVDF)	8.5 N•m (75 in-lbs)
Top & Bottom Manifolds (PFA)	3.4 N•m (30 in-lbs)
Liquid Chamber (PFA)	5.6 N•m (50 in-lbs)

SECTION 9A

EXPLODED VIEW/PARTS LISTING

P200
ADVANCED™
PLASTIC
RUBBER-
FITTED

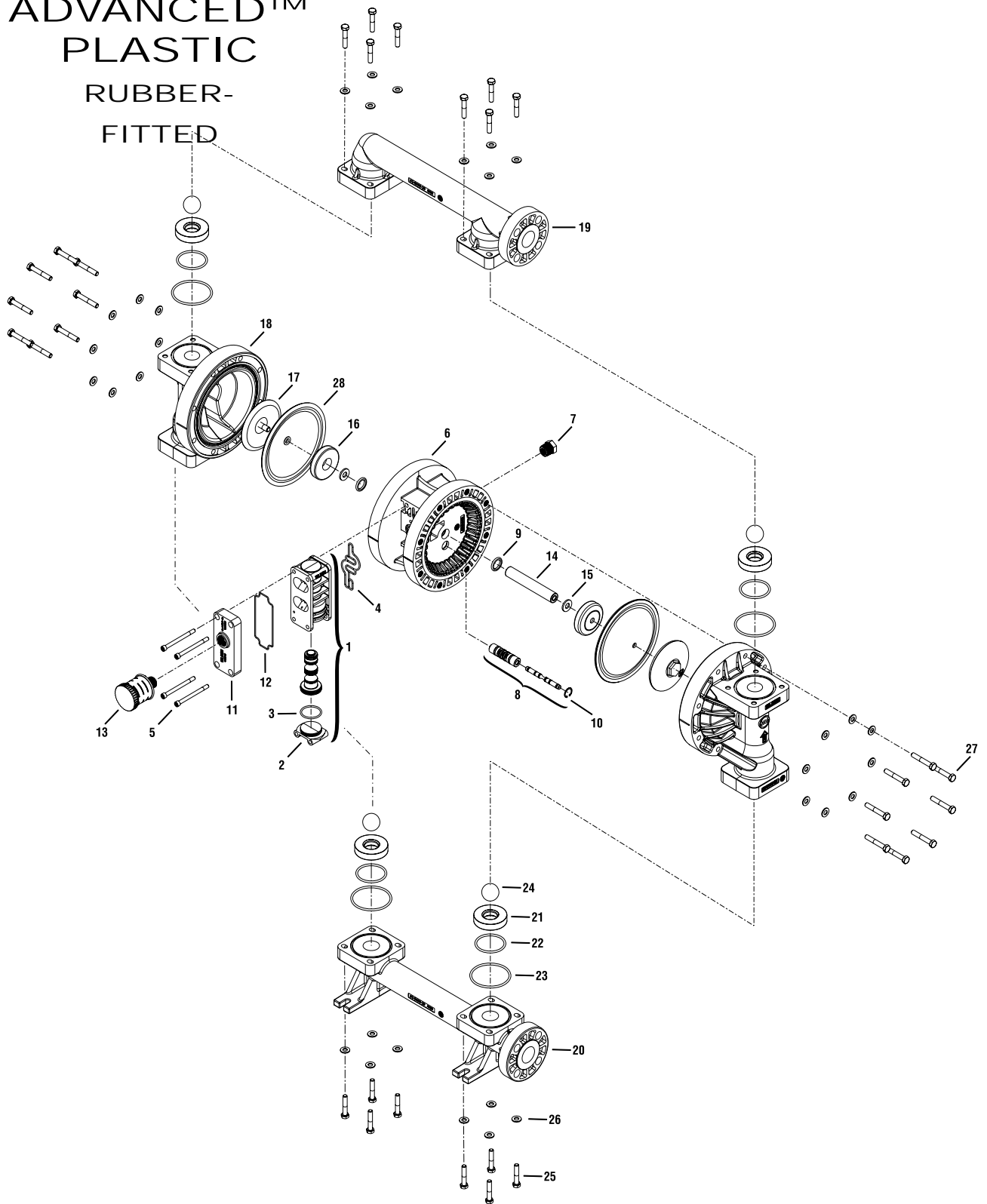

P200 ADVANCED™ PLASTIC BOLTED RUBBER-FITTED

Item	Part Description	Qty. Per Pump	P200/ PKPPP P/N	P200/ PKPPP/0502 P/N	P200/ KKPPP P/N	P200/ KKPPP/0502 P/N
1	Pro-Flo® Air Valve Assembly¹	1	01-2010-20	01-2010-20	01-2010-20	01-2010-20
2	End Cap	1	01-2332-20	01-2332-20	01-2332-20	01-2332-20
3	O-Ring, End Cap	1	01-2395-52	01-2395-52	01-2395-52	01-2395-52
4	Gasket, Air Valve	1	01-2615-52	01-2615-52	01-2615-52	01-2615-52
5	Screw, HSHC, Air Valve 1/4-20	4	01-6001-03	01-6001-05	01-6001-03	01-6001-05
6	Center Section	1	02-3142-20	02-3142-20	02-3142-20	02-3142-20
7	Bushing, Reducer	1	01-6950-20	01-6950-20	01-6950-20	01-6950-20
8	Removable Pilot Sleeve Assembly	1	02-3880-99	02-3880-99	02-3880-99	02-3880-99
9	Glyd™ Ring II	2	02-3210-55-225	02-3210-55-225	02-3210-55-225	02-3210-55-225
10	Retaining Ring	2	00-2650-03	00-2650-03	00-2650-03	00-2650-03
11	Muffler Plate	1	01-3181-20	01-3181-20	01-3181-20	01-3181-20
12	Gasket, Muffler Plate	1	01-3505-52	01-3505-52	01-3505-52	01-3505-52
13	Muffler	1	02-3510-99	02-3510-99	02-3510-99	02-3510-99
14	Shaft, Pro-Flo®	1	02-3810-03	02-3810-03	02-3810-03	02-3810-03
15	Disc Spring (Belleville Washer)	2	02-6802-08	02-6802-08	02-6802-08	02-6802-08
16	Inner Piston	2	02-3701-01	02-3701-01	02-3701-01	02-3701-01
17	Outer Piston	2	02-4550-21-500	02-4550-21-500	02-4550-21-500	02-4550-21-500
18	Liquid Chamber	2	02-5005-20	02-5005-20	02-5005-21	02-5005-21
19	Discharge Manifold	1	02-5030-20	02-5030-20	02-5030-21	02-5030-21
20	Inlet Manifold	1	02-5090-20	02-5090-20	02-5090-21	02-5090-21
21	Valve Seat	4	02-1125-20	02-1125-20	02-1125-21	02-1125-21
22	Valve Seat O-Ring	4	*	*	*	*
23	Flange O-Ring	4	*	*	*	*
24	Valve Ball	4	*	*	*	*
25	Flange Bolt	16	02-6181-03	02-6181-05	02-6181-03	02-6181-05
26	Washer	32	02-6731-03	02-6731-05	02-6731-03	02-6731-05
27	Chamber Bolt	16	02-6191-03	02-6191-05	02-6191-03	02-6191-05
28	Diaphragm	2	*	*	*	*

¹Air Valve Assembly includes items 2 and 3.

*Refer to corresponding elastomer chart in Section 10.

0502 Specialty Code = PFA Coated, ANSI Flange

All boldface items are primary wear parts.
Consult Factory for DIN Flange.

EXPLODED VIEW/PARTS LISTING

P200
ADVANCED™
PLASTIC
PTFE-
FITTED

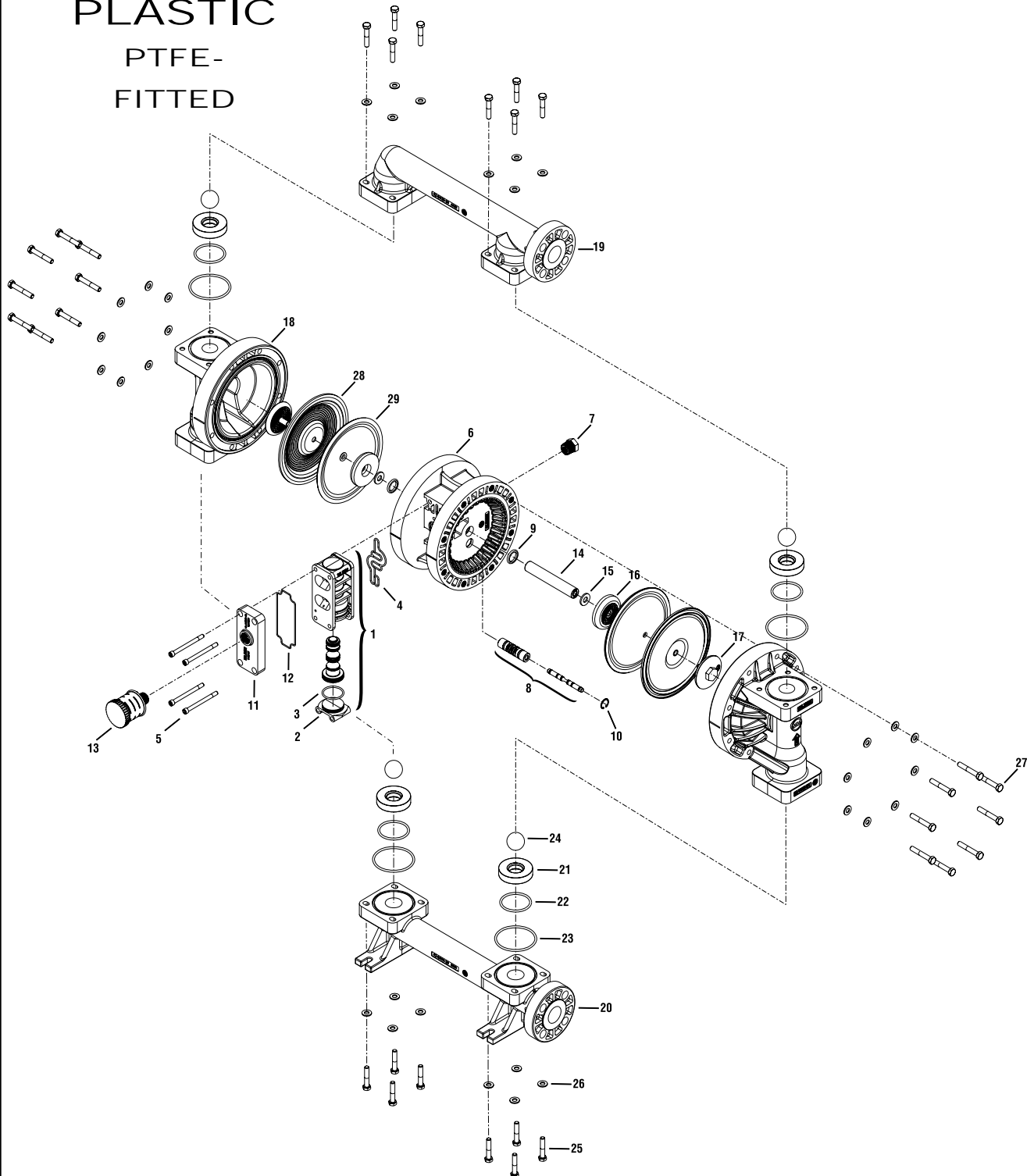

P200 ADVANCED™ PLASTIC BOLTED PTFE-FITTED

Item	Part Description	Qty. Per Pump	P200/ PKPPP P/N	P200/ PKPPP/0502 P/N	P200/ KKPPP P/N	P200/ KKPPP/0502 P/N	P200/ TTPPP P/N	P200/ TTPPP/0502 P/N
1	Pro-Flo® Air Valve Assembly¹	1	01-2010-20	01-2010-20	01-2010-20	01-2010-20	01-2010-20	01-2010-20
2	End Cap	1	01-2332-20	01-2332-20	01-2332-20	01-2332-20	01-2332-20	01-2332-20
3	O-Ring, End Cap	1	01-2395-52	01-2395-52	01-2395-52	01-2395-52	01-2395-52	01-2395-52
4	Gasket, Air Valve	1	01-2615-52	01-2615-52	01-2615-52	01-2615-52	01-2615-52	01-2615-52
5	Screw, HSHC, Air Valve 1/4-20	4	01-6001-03	01-6001-05	01-6001-03	01-6001-05	01-6001-03	01-6001-05
6	Center Section	1	02-3142-20	02-3142-20	02-3142-20	02-3142-20	02-3142-20	02-3142-20
7	Bushing, Reducer	1	01-6950-20	01-6950-20	01-6950-20	01-6950-20	01-6950-20	01-6950-20
8	Removable Pilot Sleeve Assembly	1	02-3880-99	02-3880-99	02-3880-99	02-3880-99	02-3880-99	02-3880-99
9	Glyd™ Ring II	2	02-3210-55-225	02-3210-55-225	02-3210-55-225	02-3210-55-225	02-3210-55-225	02-3210-55-225
10	Retaining Ring	2	00-2650-03	00-2650-03	00-2650-03	00-2650-03	00-2650-03	00-2650-03
11	Muffler Plate	1	01-3181-20	01-3181-20	01-3181-20	01-3181-20	01-3181-20	01-3181-20
12	Gasket, Muffler Plate	1	01-3505-52	01-3505-52	01-3505-52	01-3505-52	01-3505-52	01-3505-52
13	Muffler	1	02-3510-99	02-3510-99	02-3510-99	02-3510-99	02-3510-99	02-3510-99
14	Shaft, Pro-Flo®	1	02-3840-03	02-3840-03	02-3840-03	02-3840-03	02-3840-03	02-3840-03
15	Disc Spring (Belleville Washer)	2	02-6802-08	02-6802-08	02-6802-08	02-6802-08	02-6802-08	02-6802-08
16	Inner Piston	2	02-3751-01	02-3751-01	02-3751-01	02-3751-01	02-3751-01	02-3751-01
17	Outer Piston	2	02-4600-21-500	02-4600-21-500	02-4600-21-500	02-4600-21-500	02-4600-22	02-4600-22
18	Liquid Chamber	2	02-5005-20	02-5005-20	02-5005-21	02-5005-21	02-5005-22	02-5005-22
19	Discharge Manifold	1	02-5030-20	02-5030-20	02-5030-21	02-5030-21	02-5030-22	02-5030-22
20	Inlet Manifold	1	02-5090-20	02-5090-20	02-5090-21	02-5090-21	02-5090-22	02-5090-22
21	Valve Seat	4	02-1125-20	02-1125-20	02-1125-21	02-1125-21	02-1125-55	02-1125-55
22	Valve Seat O-Ring	4	02-1220-60	02-1220-60	02-1220-60	02-1220-60	02-1220-60	02-1220-60
23	Flange O-Ring	4	04-1300-60-500	04-1300-60-500	04-1300-60-500	04-1300-60-500	04-1300-60-500	04-1300-60-500
24	Valve Ball	4	02-1085-55	02-1085-55	02-1085-55	02-1085-55	02-1085-55	02-1085-55
25	Flange Bolt	16	02-6181-03	02-6181-05	02-6181-03	02-6181-05	02-6181-03	02-6181-05
26	Washer	32	02-6731-03	02-6731-05	02-6731-03	02-6731-05	02-6731-03	02-6731-05
27	Chamber Bolt	16	02-6191-03	02-6191-05	02-6191-03	02-6191-05	02-6191-03	02-6191-05
28	Diaphragm	2	02-1010-55	02-1010-55	02-1010-55	02-1010-55	02-1010-55	02-1010-55
29	Backup Diaphragm	2	02-1060-51	02-1060-51	02-1060-51	02-1060-51	02-1060-51	02-1060-51

¹Air Valve Assembly includes items 2 and 3.

*Refer to corresponding elastomer chart in Section 10.

0502 Specialty Code = PFA Coated, ANSI Flange

All boldface items are primary wear parts.
Consult Factory for DIN Flange.

SECTION 10

ELASTOMER OPTIONS

P200 ADVANCED™ PLASTIC

Material	Color Code	Diaphragm (2) P/N	Valve Ball (4) P/N	Valve Seat O-Ring (4) P/N	Flange O-Ring (4) P/N	Backup Diaphragm P/N
Polyurethane	Natural	02-1010-50	02-1085-50	02-1220-50	04-1300-50-500	N/A
Buna-N	Red	02-1010-52	02-1085-52	04-2390-52-700	04-1300-52-500	N/A
PTFE Encapsulated Viton®	None	N/A	N/A	02-1220-60	04-1300-60-500	N/A
Neoprene	Green	02-1010-51	02-1085-51	N/A	N/A	02-1060-56
Viton®	Silver	02-1010-53	02-1085-53	N/A	N/A	N/A
EPDM	Blue	02-1010-54	02-1085-54	N/A	N/A	02-1060-541
PTFE	White	02-1010-55	02-1085-55	N/A	N/A	N/A
Tetra-Flex™ PTFE w/Neoprene	White	02-1010-64	N/A	N/A	N/A	N/A
Tetra-Flex™ PTFE w/EPDM	White	02-1010-81	N/A	N/A	N/A	N/A
Saniflex™	Off-White	02-1010-56	02-1085-56	N/A	N/A	02-1060-561
Wil-Flex™	Orange	02-1010-58	02-1085-58	02-1220-58	02-1370-58	N/A

*Saniflex™ and EPDM back-up diaphragms are available upon request. Please consult your local distributor.

WARRANTY

Each and every product manufactured by Wilden Pump and Engineering, LLC is built to meet the highest standards of quality. Every pump is functionally tested to insure integrity of operation.

Wilden Pump and Engineering, LLC warrants that pumps, accessories and parts manufactured or supplied by it to be free from defects in material and workmanship for a period of five (5) years from date of installation or six (6) years from date of manufacture, whichever comes first. Failure due to normal wear, misapplication, or abuse is, of course, excluded from this warranty.

Since the use of Wilden pumps and parts is beyond our control, we cannot guarantee the suitability of any pump or part for a particular application and Wilden Pump and Engineering, LLC shall not be liable for any consequential damage or expense arising from the use or misuse of its products on any application. Responsibility is limited solely to replacement or repair of defective Wilden pumps and parts.

All decisions as to the cause of failure are the sole determination of Wilden Pump and Engineering, LLC.

Prior approval must be obtained from Wilden for return of any items for warranty consideration and must be accompanied by the appropriate MSDS for the product(s) involved. A Return Goods Tag, obtained from an authorized Wilden distributor, must be included with the items which must be shipped freight prepaid.

The foregoing warranty is exclusive and in lieu of all other warranties expressed or implied (whether written or oral) including all implied warranties of merchantability and fitness for any particular purpose. No distributor or other person is authorized to assume any liability or obligation for Wilden Pump and Engineering, LLC other than expressly provided herein.

PLEASE PRINT OR TYPE AND FAX TO WILDEN

PUMP INFORMATION			
Item # _____		Serial # _____	
Company Where Purchased _____			
YOUR INFORMATION			
Company Name _____			
Industry _____			
Name _____		Title _____	
Street Address _____			
City _____		State _____	Country _____
Telephone _____		Fax _____	Web Address _____
Number of pumps in facility? _____		Number of Wilden pumps? _____	
Types of pumps in facility (check all that apply): <input type="checkbox"/> Diaphragm <input type="checkbox"/> Centrifugal <input type="checkbox"/> Gear <input type="checkbox"/> Submersible <input type="checkbox"/> Lobe			
<input type="checkbox"/> Other _____			
Media being pumped? _____			
How did you hear of Wilden Pump? <input type="checkbox"/> Trade Journal <input type="checkbox"/> Trade Show <input type="checkbox"/> Internet/E-mail <input type="checkbox"/> Distributor			
<input type="checkbox"/> Other _____			

ONCE COMPLETE, FAX TO (909) 783-3440

NOTE: WARRANTY VOID IF PAGE IS NOT FAXED TO WILDEN

WILDEN PUMP & ENGINEERING, LLC