

Enhance your process

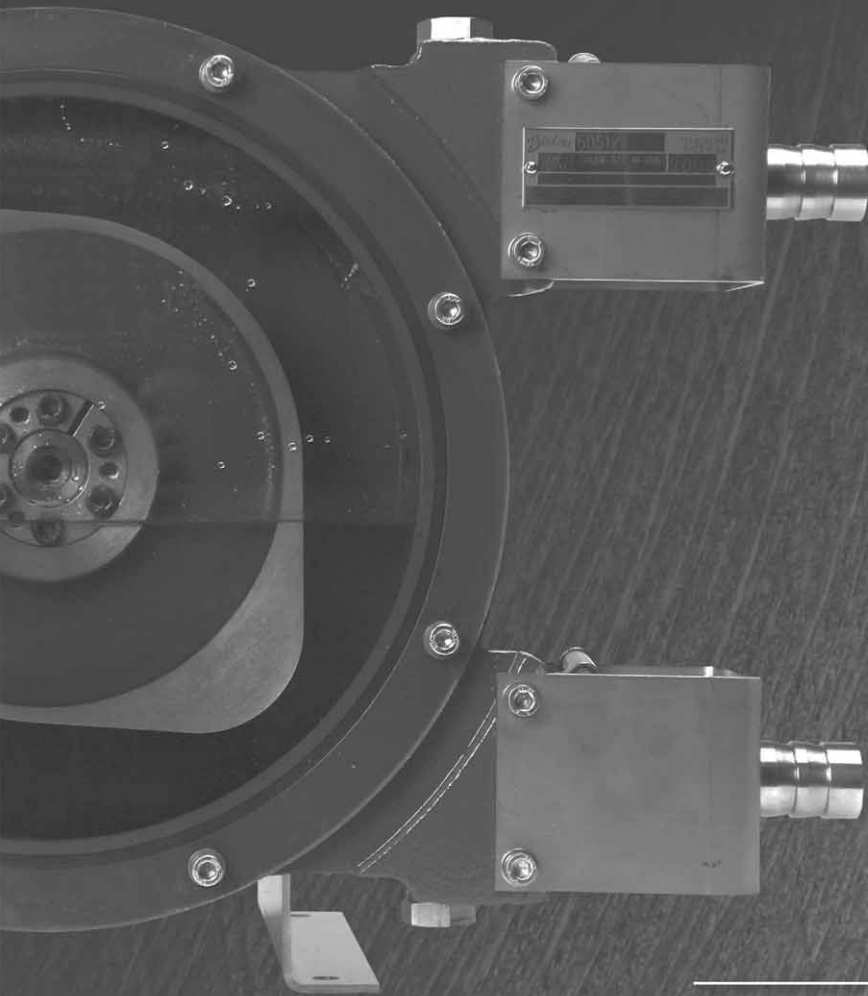

**KC 40**  
**KC X40**  
**KC 65**



**WILDEN®**

A DOVER COMPANY

WIL-30020-E-02  
TO REPLACE WIL-30020-E-01

**TABLE OF CONTENTS**

**SECTION 1 CAUTIONS—READ FIRST! .....1**

**SECTION 2 KING COBRA™ PUMP DESIGNATION SYSTEM .....2**

**SECTION 3 HOW IT WORKS—PERISTALTIC HOSE TECHNOLOGY .....3**

**SECTION 4 DIMENSIONAL DRAWINGS .....4**

**SECTION 5 PERFORMANCE**

    How to Read Performance Curves .....6

    KCS40 & KCG40 .....7

    KCSX40 & KCGX40 .....7

    KCS65 & KCG65 .....8

**SECTION 6 SUGGESTED INSTALLATION, OPERATION & TROUBLESHOOTING .....9**

**SECTION 7 PUMP DISASSEMBLY ..... 11**

    Shimming & Hose Compression .....13

    Setting Hose Compression .....13

    Hose Compression Tables .....14

    Installing the Wheel .....15







    Installing the Hose .....16

    Final Assembly .....17

**SECTION 8 REPLACEMENT PARTS .....20**

## CAUTIONS—READ FIRST!

- 
**CAUTION:** Only personnel who are familiar with the operation and repair of mechanical products should perform the necessary maintenance. You must familiarize yourself with the entire contents of this manual prior to operating and/or performing any maintenance.
  
- 
**MAXIMUM HOSE TEMPERATURE LIMITS:**

Natural Rubber (NR)	70°C (158°F)
Buna-N (NBR)	70°C (158°F)
EPDM	80°C (176°F)
  
- 
**CAUTION:** When pumping high temperature fluids, avoid contact with the pump. Serious injury could occur.
  
- 
**CAUTION:** Ensure that the pump has cooled to a safe temperature before any maintenance or repair is attempted.
  
- 
**CAUTION:** Before any repair or maintenance is attempted, ensure that the pump has been thoroughly flushed of any hazardous fluids. Review the material Safety Data Sheet (MSDS) application to the fluid for proper handling.
  
- 
**CAUTION:** Before any maintenance is attempted, disconnect the electricity supply or serious injury could occur.
  
- 
**CAUTION:** Before any maintenance is attempted, disconnect the drive.
  
- 
**CAUTION:** Before any maintenance or repair is attempted, bleed all pressure from the pump through the suction or discharge lines.
  
- 
**CAUTION:** When performing maintenance to the pump, be careful when handling pump components. Some of the pump components are heavy and can cause serious injury if not handled properly.
  
- 
**CAUTION:** When selecting a King Cobra™ peristaltic hose pump for an application, you must first ensure that the pump components are compatible with the process media.
  
- 
**CAUTION:** Do not operate this pump in excess of its rated capacity, pressure, speed and temperature.
  
- 
**CAUTION:** Never, under any circumstances attempt to install the hose or operate the pump without the pump casing cover and the casing cover window properly secured to the casing of the pump.
  
- 
**CAUTION:** Prevention of static sparking – If static sparking occurs, fire or explosion could result. Pump, valves, and containers must be grounded to a proper grounding point when handling flammable fluids and whenever discharge of static electricity is a hazard.
  
- 
**CAUTION:** All inlet and discharge plumbing should be clean and free from foreign material prior to start-up of pump.
  
- 
**CAUTION:** When connecting to an electric motor, follow all safety recommendation provided by the motor manufacturer.
  
- 
**CAUTION:** Never remove safety guards from shafts, couplings, V-belts, or pulleys during operation. Doing so could result in injury.
  
- 
**CAUTION:** Do not wear loose or dangling clothing or jewelry near the equipment. These items could become caught in the equipment.
  
- 
**CAUTION:** A King Cobra™ peristaltic hose pump is a heavy piece of industrial equipment. Use suitable lifting devices that are capable of lifting the weight of the pump.
  
- 
**CAUTION:** Do not handle pump without the pump casing cover in place. Doing so could result in serious injury.
  
- 
**CAUTION:** Be careful when removing pump lubricant from pump casing. Lubricant is very slippery and can cause serious injury if spillage occurs.



**WILDEN DESIGNATION SYSTEM**

**PERISTALTIC HOSE PUMPS**

**LEGEND**

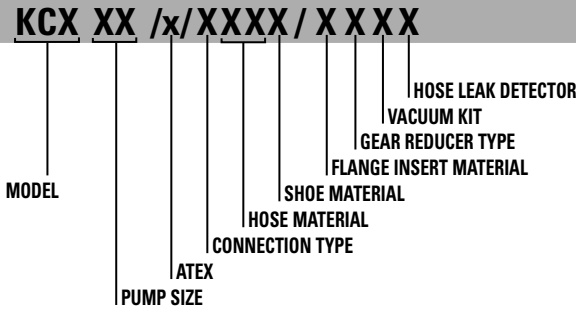

**MATERIAL CODES**

**MODEL**

- KCS = Flat Pack (pump only)
- KCG = Pump and Gear Reducer

*Note: The Flat Pack version is pump only and doesn't include the gear reducer.*

**PUMP SIZE**

- 10 = 10mm (3/8") Barbed Inlet/Discharge
- 20 = 19mm (3/4") Barbed Inlet/Discharge
- 25 = 25mm (1") Flanged Inlet/Discharge
- 40 = 40mm (1-1/2") Flanged Inlet/Discharge
- X40 = 40mm (1-1/2") Flanged Inlet/Discharge
- 65 = 65mm (2-1/2") Flanged Inlet/Discharge

*Note: The difference between the KC40 and the KCX40 is that the KCX40 provides a greater flow rate than the KC40 model.*

**ATEX**

- X = ATEX
- Z = Non-ATEX

**CONNECTION TYPE**

- A = Barbed Hose
- B = ANSI Flange
- C = PN16 Flange

*Note: KC10 & KC20 pumps are available with barb type hose connections ONLY. KC25 through KC65 pumps are available with flange connections ONLY.*

**HOSE MATERIAL**

- NR = Natural Rubber
- BN = Buna-N
- EP = EPDM

**SHOE MATERIAL**

- A = Aluminum
- C = Cast Iron

*Note: The shoe and wheel fitted to the KC10 and KC20 are molded as one component and are only available in cast iron. The shoe and wheel fitted to the KC25 through KC65 are separate components and available in aluminum or cast iron.*

**FLANGE INSERT MATERIAL**

- P = Polypropylene
- K = PVDF
- S = Stainless Steel

**GEAR REDUCER TYPE**

- A = Designed to accept NEMA motors
- D = Designed to accept IEC motors
- Z = No Gear Reducer, (KCS Model)

**VACUUM KIT**

- A = Consult factory for models prepared to accept vacuum kit (only available on 25mm (1") through 65mm (2-1/2"))
- Z = No Vacuum Kit

**HOSE LEAK DETECTOR**

- A = Includes Leak Detector
- Z = No Leak Detector

Note: The pump casing is available in cast iron only.



## HOW IT WORKS

The Wilden peristaltic hose pump is a rotating, positive displacement pump. The drawings below show the flow pattern through the pump upon its initial rotation. It is assumed that the pump has no fluid in it prior to its initial rotation.

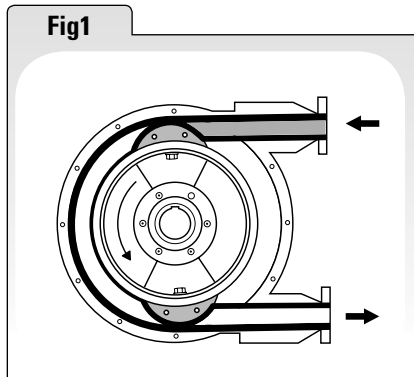

The peristaltic pumping action is achieved by compression of an elastomeric hose against a pump casing by two rotating shoes. (Fig. 1).

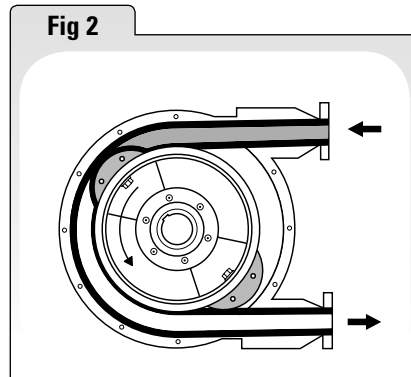

As the shoes rotate around the hose, the reinforced hose immediately returns to its original shape creating a vacuum at the inlet of the pump. Atmospheric pressure forces fluid into the inlet of the pump and into the hose. (Fig. 2)

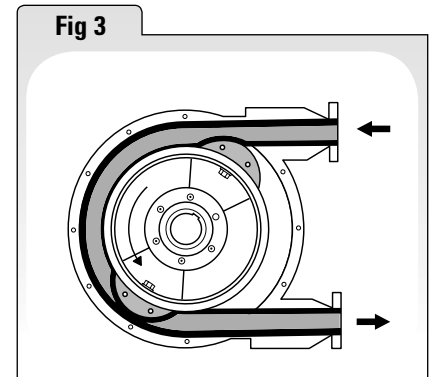

When each shoe rotates 360° and reaches the end of the hose the liquid within the hose is forced out of the discharge of the pump. The pump may take several rotations depending on the conditions of the application. (Fig. 3)

**Note:** The user can also reverse the motor for a variety of process application needs. The pump casing is partially filled with lubricant to reduce friction of the shoes on the hose. The inside of the hose and hose inserts are the only wetted components in contact with process fluids, allowing aggressive and/or contaminated fluids to be pumped safely, reliably, and effectively.



**DIMENSIONAL DRAWINGS**

**KCS (Flat Pack - Pump Only)**

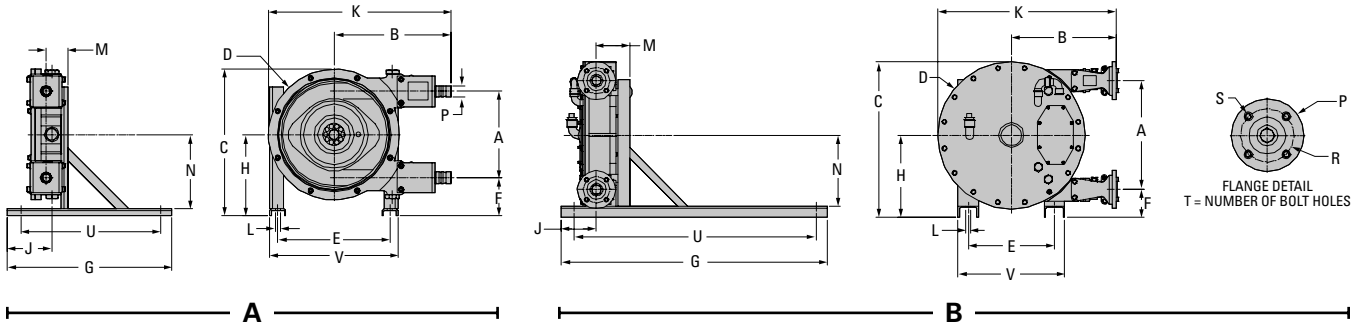

**DIMENSIONS (inches)**

	PUMP	A	B	C	D	E	F	G	H	J	K	L	M	N	P	R	S	T	U	V
T A	KCS10 BARBED	4.5	8.2	8.5	Ø7.5	6.2	2.5	14.4	4.7	3.7	12.2	Ø.35	1.6	4.1	Ø.50	N/A	N/A	N/A	12.2	8.0
	KCS20 BARBED	7.6	10.2	12.8	Ø11.4	9.8	3.3	14.4	7.1	3.4	15.9	Ø.35	1.9	6.5	Ø.98	N/A	N/A	N/A	12.2	11.2
B	KCS25 PN16 (DIN)	10.3	12.2	16.3	Ø15.0	9.1	3.7	24.4	8.9	4.8	20.1	Ø.59	3.3	7.7	Ø4.53	Ø3.35	Ø.55	4.0	22.4	11.4
	KCS25 ANSI 150	10.3	12.2	16.3	Ø15.0	9.1	3.7	24.4	8.9	4.8	20.1	Ø.59	3.3	7.7	Ø4.33	Ø3.13	Ø.63	4.0	22.4	11.4
	KCS40 PN16 (DIN)	13.0	15.1	20.6	Ø18.7	12.4	4.8	29.9	11.3	7.1	24.7	Ø.59	2.9	10.1	Ø5.91	Ø4.33	Ø.71	4.0	26.0	14.8
	KCS40 ANSI 150	13.0	15.1	20.6	Ø18.7	12.4	4.8	29.9	11.3	7.1	24.7	Ø.59	2.9	10.1	Ø5.12	Ø3.88	Ø.63	4.0	26.0	14.8
	KCSX40 PN16 (DIN)	16.9	16.4	24.3	Ø22.9	13.4	4.3	41.3	12.8	5.5	28.1	Ø.59	2.6	11.0	Ø5.91	Ø4.33	Ø.71	4.0	37.4	16.5
	KCSX40 ANSI 150	16.9	16.4	24.3	Ø22.9	13.4	4.3	41.3	12.8	5.5	28.1	Ø.59	2.6	11.0	Ø5.12	Ø3.88	Ø.63	4.0	37.4	16.5
	KCS65 PN16 (DIN)	21.8	17.9	31.6	Ø28.4	20.0	6.5	41.3	17.4	8.1	32.2	Ø.75	3.7	15.6	Ø7.28	Ø5.71	Ø.71	8.0	37.4	23.2
	KCS65 ANSI 150	21.8	18.1	31.6	Ø28.4	20.0	6.5	41.3	17.4	8.1	32.4	Ø.75	3.7	15.6	Ø7.09	Ø5.49	Ø.71	4.0	37.4	23.2

**DIMENSIONS (millimeters)**

	PUMP	A	B	C	D	E	F	G	H	J	K	L	M	N	P	R	S	T	U	V
T A	KCG10 BARBED	115	209	215	Ø190	168	63	365	120	94	310	Ø9	42	105	Ø13	N/A	N/A	N/A	310	203
	KCG20 BARBED	192	259	325	Ø290	249	84	365	180	87	404	Ø9	49	165	Ø25	N/A	N/A	N/A	310	284
B	KCS25 PN16 (DIN)	262	311	415	Ø380	230	94	620	225	121	501	Ø15	83	195	Ø115	Ø85	Ø14	4	570	290
	KCS25 ANSI 150	262	311	415	Ø380	230	94	620	225	121	501	Ø15	83	195	Ø110	Ø80	Ø16	4	570	290
	KCS40 PN16 (DIN)	330	383	524	Ø476	315	121	760	286	179	621	Ø15	74	256	Ø150	Ø110	Ø18	4	660	375
	KCS40 ANSI 150	330	384	524	Ø476	315	121	760	286	179	621	Ø15	74	256	Ø130	Ø99	Ø16	4	660	375
	KCSX40 PN16 (DIN)	430	416	616	Ø582	340	110	1050	325	140	707	Ø15	66	280	Ø150	Ø110	Ø18	4	950	420
	KCSX40 ANSI 150	430	417	616	Ø582	340	110	1050	325	140	708	Ø15	66	280	Ø130	Ø99	Ø16	4	950	420
	KCS65 PN16 (DIN)	554	455	802	Ø720	509	165	1050	442	205	815	Ø19	95	397	Ø185	Ø145	Ø18	8	950	589
	KCS65 ANSI 150	554	460	802	Ø720	509	165	1050	442	205	820	Ø19	95	397	Ø180	Ø140	Ø18	4	950	589

## KCG (Pump & Reducer)

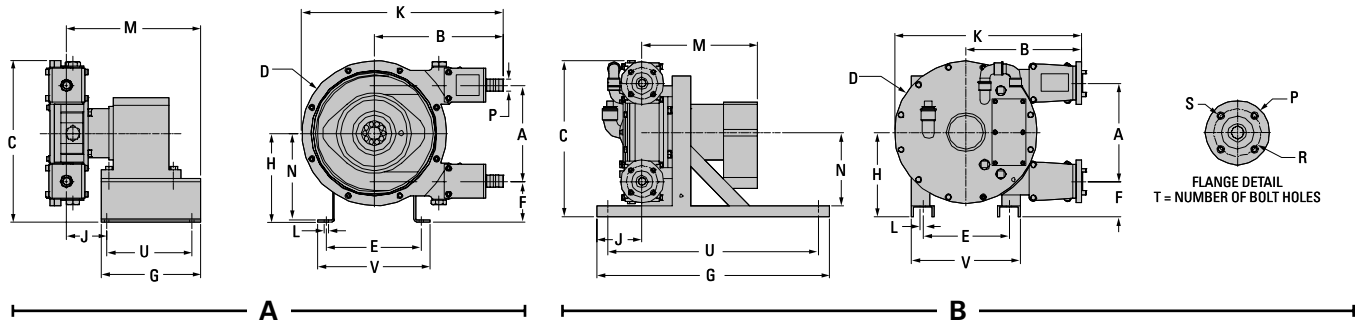

### DIMENSIONS (inches)

	PUMP	A	B	C	D	E	F	G	H	J	K	L	M	N	P	R	S	T	U	V
T A	KCG10 BARBED	4.5	8.2	15.2	7.5	7.5	2.2	7.8	*	**	11.9	Ø.35	7.89	***	Ø.63	N/A	N/A	N/A	6.69	8.86
	KCG20 BARBED	7.6	10.2	12.6	11.4	7.5	3.2	7.9	▲	▲▲	15.9	Ø.35	8.01	▲▲▲	Ø.98	N/A	N/A	N/A	6.69	8.86
B	KCG25 PN16 (DIN)	10.3	12.2	16.3	15.0	9.1	3.7	24.4	8.9	4.8	19.7	Ø.59	12.11	7.68	Ø4.53	Ø3.35	Ø.55	4.00	22.44	11.42
	KCG25 ANSI 150	10.3	12.2	16.3	15.0	9.1	3.7	24.4	8.9	4.8	19.7	Ø.59	12.11	7.68	Ø4.33	Ø3.13	Ø.63	4.00	22.44	11.42
	KCG40 PN16 (DIN)	13.0	15.1	20.6	18.7	12.4	4.8	29.9	11.3	5.1	24.4	Ø.59	12.01	10.08	Ø5.91	Ø4.33	Ø.71	4.00	25.98	14.76
	KCG40 ANSI 150	13.0	15.1	20.6	18.7	12.4	4.8	29.9	11.3	7.1	24.5	Ø.59	12.01	10.08	Ø5.12	Ø3.88	Ø.63	4.00	25.98	14.76
	KCGX40 PN16 (DIN)	16.9	16.4	24.3	22.9	13.4	4.3	41.3	12.8	5.5	27.8	Ø.59	12.40	11.02	Ø5.91	Ø4.33	Ø.71	4.00	37.40	16.54
	KCGX40 ANSI 150	16.9	16.4	24.3	22.9	13.4	4.3	41.3	12.8	5.5	27.9	Ø.59	12.40	11.02	Ø5.12	Ø3.88	Ø.63	4.00	37.40	16.54
	KCG65 PN16 (DIN)	21.8	17.9	32.8	28.3	20.0	6.5	41.3	17.4	8.1	32.1	Ø.75	15.08	15.63	Ø7.28	Ø5.71	Ø.71	8.00	37.40	23.19
	KCG65 ANSI 150	21.8	18.1	32.8	28.3	20.0	6.5	41.3	17.4	8.1	32.3	Ø.79	15.08	15.63	Ø7.09	Ø5.49	Ø.71	4.00	37.40	23.19

\* 10 RPM = 6.4 ; 25,40, 60 RPM = 7.0      \*\*\* 10 RPM = 6.3 ; 25,40,60 RPM = 6.9      ▲▲ 10 RPM = 1.8 ; 25, 40, 60 RPM = 2.7  
 \*\* 10 RPM = 1.4 ; 25,40,60 RPM = 2.6      ▲ 10 RPM = 6.6 ; 25, 40, 60 RPM = 7.0      ▲▲▲ 10 RPM = 6.5 ; 25, 40, 60 RPM = 6.9

### DIMENSIONS (millimeters)

	PUMP	A	B	C	D	E	F	G	H	J	K	L	M	N	P	R	S	T	U	V
T A	KCG10 BARBED	115	209	384	Ø190	190	44	199	*	**	304	Ø9	201	***	Ø16	N/A	N/A	N/A	170	225
	KCG20 BARBED	192	259	320	Ø290	190	81	199	▲	▲▲	404	Ø9	204	▲▲▲	Ø25	N/A	N/A	N/A	170	225
B	KCG25 PN16 (DIN)	262	311	415	Ø380	230	94	620	225	121	501	Ø15	308	195	Ø115	Ø85	Ø14	4	570	290
	KCG25 ANSI 150	262	311	415	Ø380	230	94	620	225	121	502	Ø15	308	195	Ø110	Ø80	Ø16	4	570	290
	KCG40 PN16 (DIN)	330	383	524	Ø476	315	121	760	286	129	621	Ø15	305	256	Ø150	Ø110	Ø18	4	660	375
	KCG40 ANSI 150	330	384	524	Ø476	315	121	760	286	179	622	Ø15	305	256	Ø130	Ø99	Ø16	4	660	375
	KCGX40 PN16 (DIN)	430	416	616	Ø582	340	110	1050	325	140	707	Ø15	315	280	Ø150	Ø110	Ø18	4	950	420
	KCGX40 ANSI 150	430	417	616	Ø582	340	110	1050	325	140	708	Ø15	315	280	Ø130	Ø99	Ø16	4	950	420
	KCG65 PN16 (DIN)	554	455	832	Ø720	509	165	1050	442	205	815	Ø19	383	397	Ø185	Ø145	Ø18	8	950	589
	KCG65 ANSI 150	554	460	832	Ø720	509	165	1050	442	205	820	Ø19	383	397	Ø180	Ø140	Ø18	4	950	589

\* 10 RPM = 162.6 ; 25, 40, 60 RPM = 177.8      \*\*\* 10 RPM = 160.0 ; 25, 40, 60 RPM = 175.3      ▲▲ 10 RPM = 45.7 ; 25, 40, 60 RPM = 68.6  
 \*\* 10 RPM = 35.6 ; 25, 40, 60 RPM      ▲ 10 RPM = 167.6 ; 25, 40 60 RPM = 177.8      ▲▲▲ 10 RPM = 165.1 ; 25, 40, 60 RPM = 175.3



**PERFORMANCE**

**HOW TO READ PERFORMANCE CURVES**

To determine the flow rate of your King Cobra™ pump 5 key factors need to be taken into consideration; pump speed, motor power, viscosity, fluid temperature and continuous or intermittent service. Prior to reading the performance curves take a few minutes and read through the simple-to-understand tutorial on the following pages.

Ultimately, the final determination for flow rate depends on which of the 5 key factors are most critical to your application. Going through this process, combined with shimming the wheel of your pump (described in the assembly section) will assist you with customizing your King Cobra™ pump for your application needs.

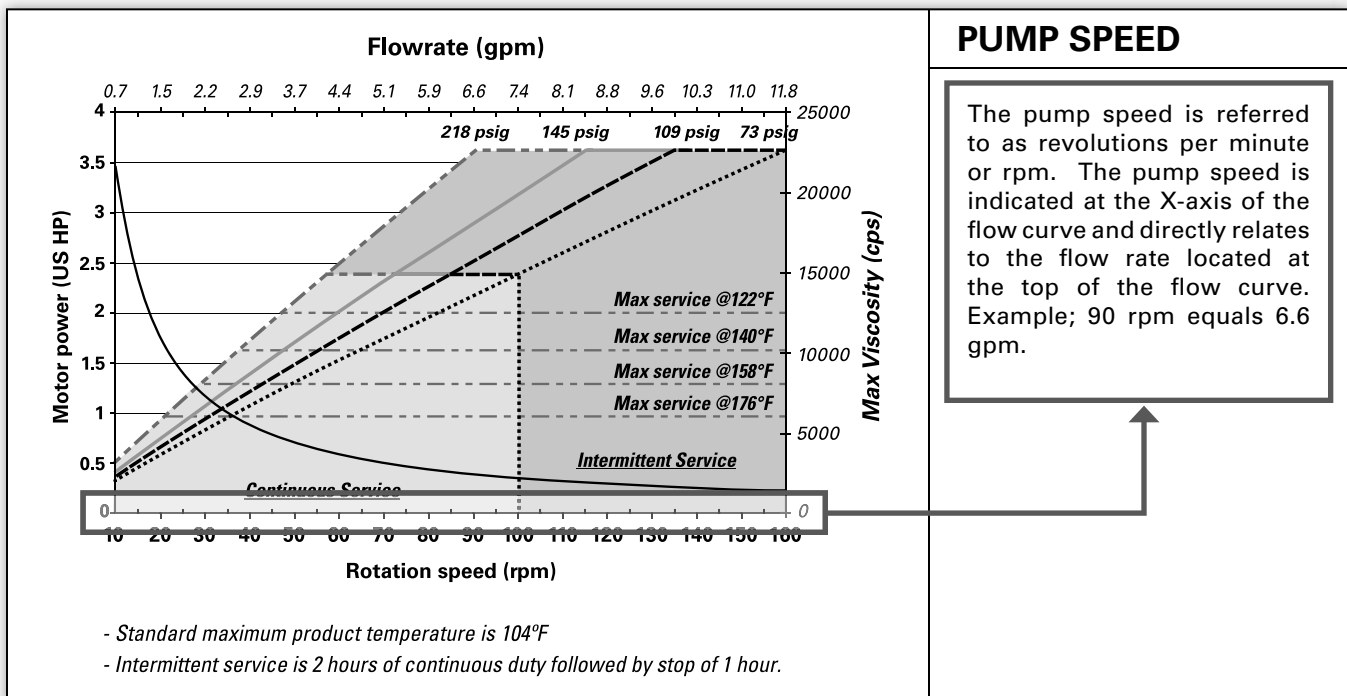
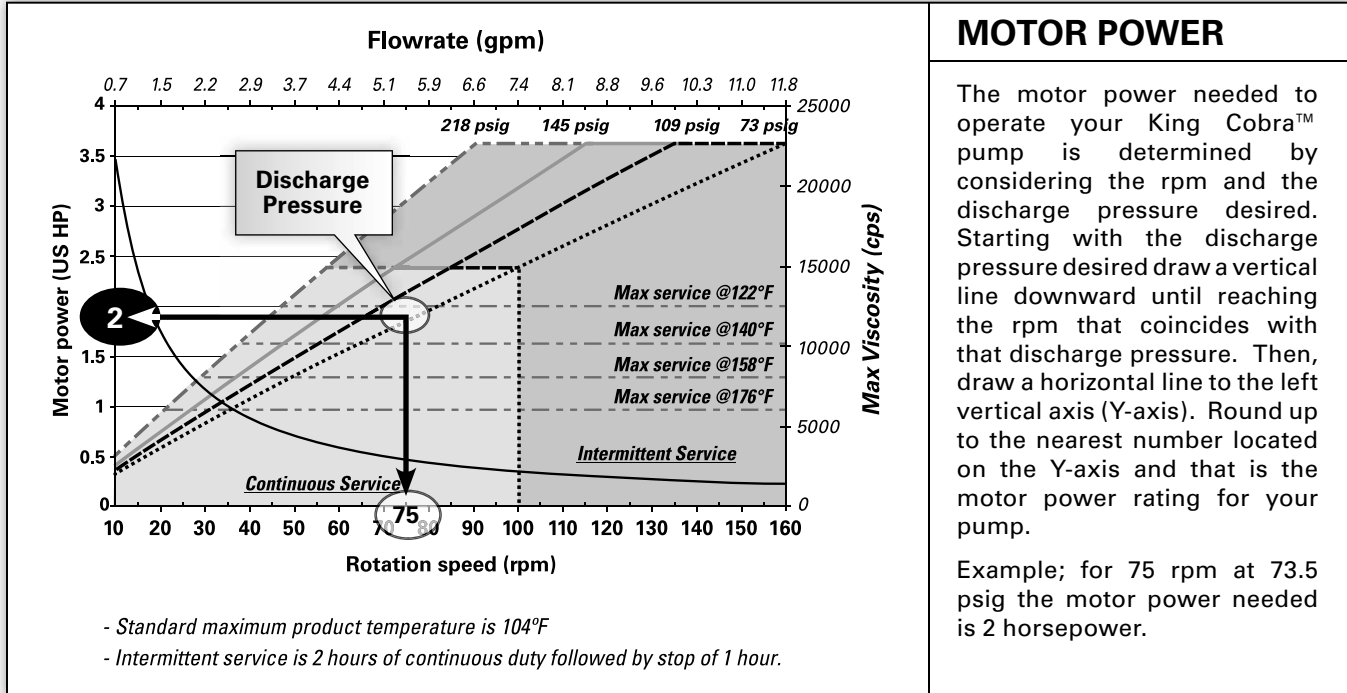

# HOW TO READ PERFORMANCE CURVES

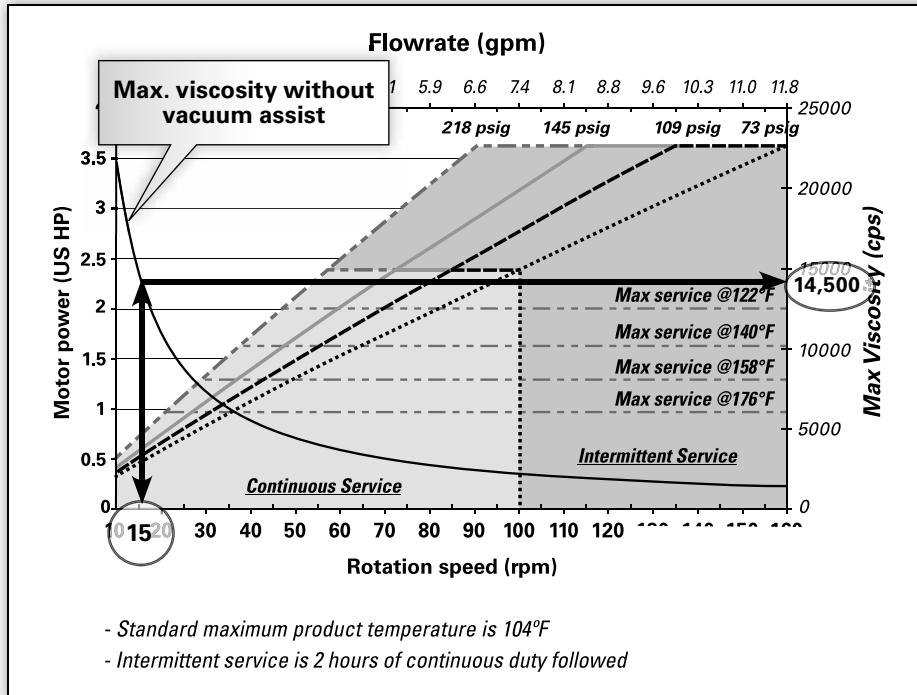

## VISCOSITY LIMITS

The viscosity is indicated at the right vertical axis (Y2-axis) of the flow curve. The maximum viscosity limit is determined by the rpm, max., the viscosity without vacuum assist line and the viscosity at the right of the curve. First, find the rpm at the X-axis of the curve. Then, draw a line upward until reaching the max. viscosity limit w/o vacuum line. From there, draw a horizontal line to the Y-axis. This is the viscosity limit for your pump.

Example; maximum viscosity limit without the vacuum assist option at 15 rpm is 14,500 cps.

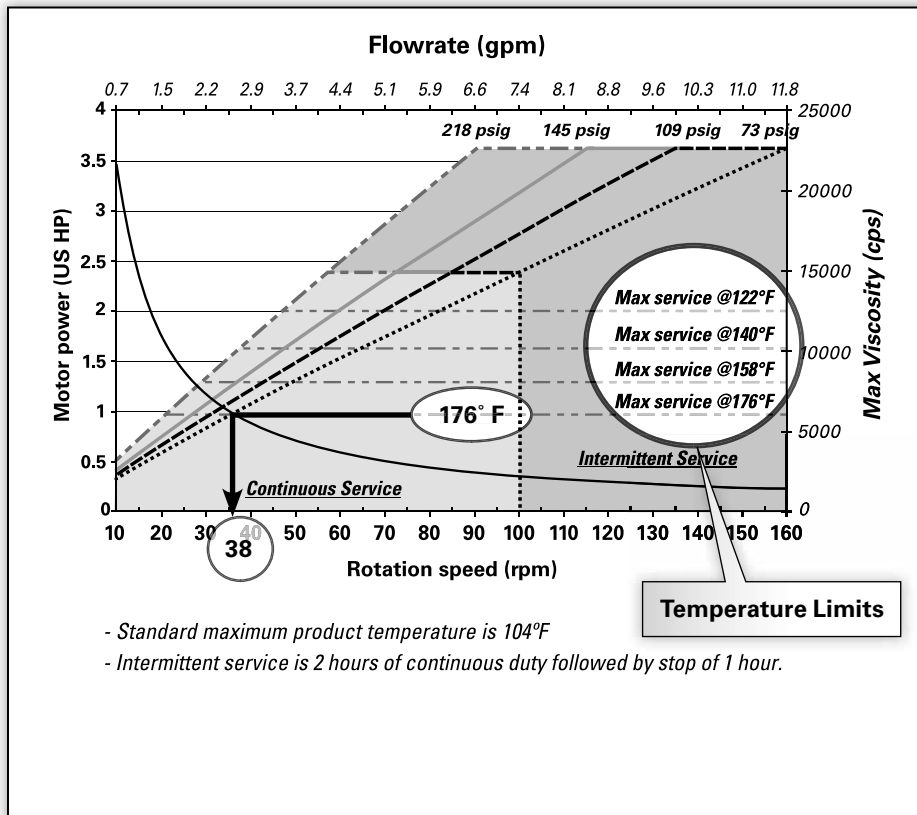

## TEMPERATURE LIMITS

Temperature is another key factor to include when determining your pumps flow rate. In the diagram to the left, the max. service temperature is located within the large circle. Discharge pressure and rpm are the other key factors when determining the maximum operating temperature of your King Cobra™ pump. CAUTION: Maximum temperature limits are based upon mechanical stress only. Certain chemicals will significantly reduce maximum safe operating temperatures.

Example; under 73 psig and intermittent service the pump is limited to 160 rpm below 122° F. At continuous service and 176° F. with discharge pressure at 73 psig. the rpm allowable changes to 38.

# HOW TO READ PERFORMANCE CURVES

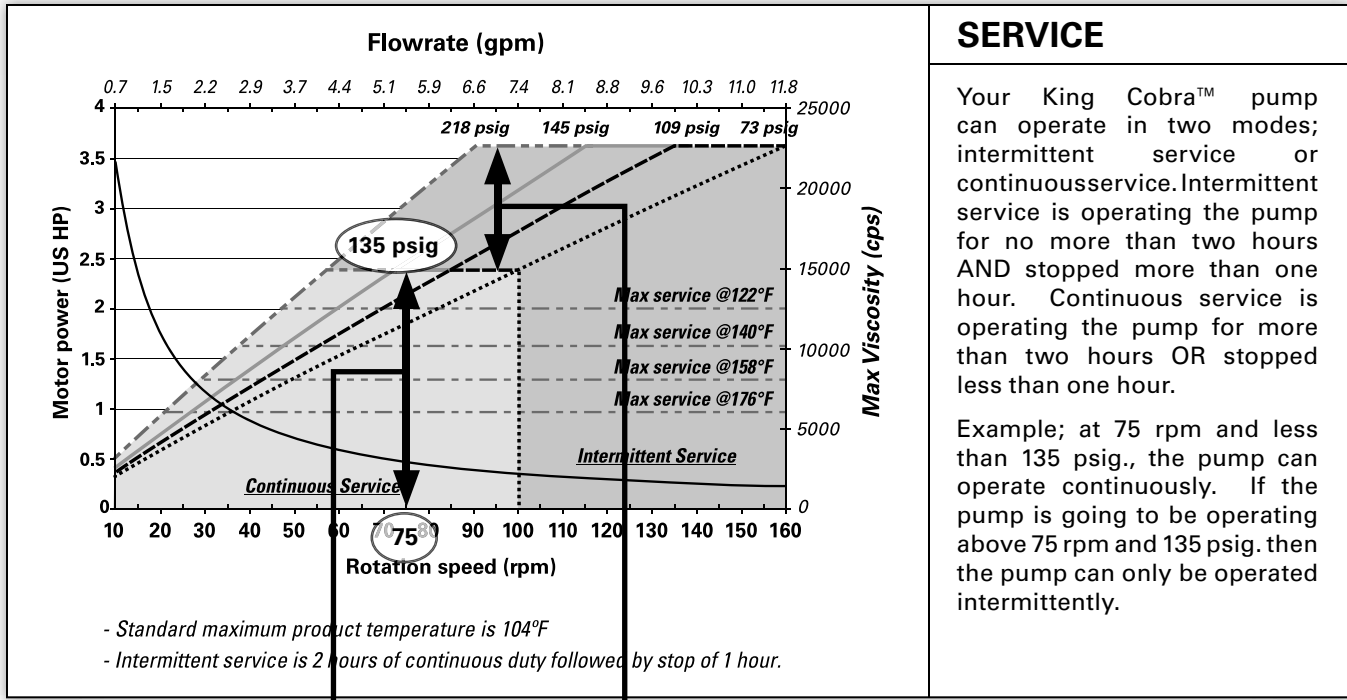

## SERVICE

Your King Cobra™ pump can operate in two modes; intermittent service or continuous service. Intermittent service is operating the pump for no more than two hours AND stopped more than one hour. Continuous service is operating the pump for more than two hours OR stopped less than one hour.

Example; at 75 rpm and less than 135 psig., the pump can operate continuously. If the pump is going to be operating above 75 rpm and 135 psig. then the pump can only be operated intermittently.

The light grey area indicated on the flow curve is the Continuous Service zone. The pump can operate continuously at the flow parameters within this area of the flow curve.

The dark grey area indicated on the flow curve is the Intermittent Service zone. The pump can operate intermittently at the flow parameters within this area of the flow curve.

## KCS40 & KSG40

Height ..... 524mm (20.6")  
 Width ..... 660mm (26.0")  
 Depth ..... 620mm (24.4")  
 Est. Ship Weight (pump only) kg (lbs)... 102kg (225lbs)  
 Connection Type..... Flanged  
 Inlet ..... 38mm (1-1/2")  
 Discharge..... 38mm (1-1/2")  
 Suction Lift - Dry: ..... 9m (25.9')  
 Max. Viscosity @ 10 rpm ..... 25,000 cps  
 Max. Flow Rate, Intermittent - m<sup>3</sup>/h (gpm)  
 ..... 7.23 (31.83)  
 Max. Flow Rate, Constant - m<sup>3</sup>/h (gpm)  
 ..... 4.65 (20.47)  
 Max. Discharge Pressure 15 bar (217.5 psig)  
 Cylinder Capacity..... 0.861 dm<sup>3</sup>

**Note: Maximum solids passage is no greater than 25% of the inside diameter of the hose.**

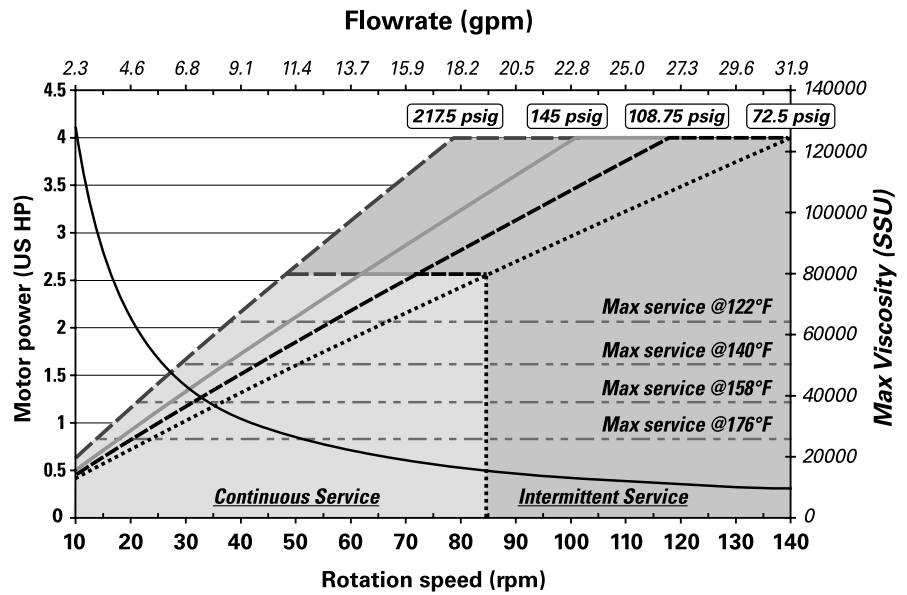

- Standard maximum product temperature is 104°F  
 - Intermittent service is 2 hours of continuous duty followed by stop of 1 hour.

## KCSX40 & KSGX40

Height ..... 616mm (24.3")  
 Width ..... 950mm (37.4")  
 Depth ..... 707mm (27.8")  
 Est. Ship Weight (pump only) kg (lbs)... 130kg (287lbs)  
 Connection Type..... Flanged  
 Inlet ..... 38mm (1-1/2")  
 Discharge..... 38mm (1-1/2")  
 Suction Lift - Dry: ..... 9m (25.9')  
 Max. Viscosity @ 10 rpm ..... 20,000 cps  
 Max. Flow Rate, Intermittent - m<sup>3</sup>/h (gpm)  
 ..... 9.60 (42.47)  
 Max. Flow Rate, Constant - m<sup>3</sup>/h (gpm)  
 ..... 6.40 (28.18)  
 Max. Discharge Pressure 15 bar (217.5 psig)  
 Cylinder Capacity..... 1.141 dm<sup>3</sup>

**Note: This configuration includes a longer hose and produces a greater flow rate. Only available on 40mm (1-1/2") model.**

**Note: Maximum solids passage is no greater than 25% of the inside diameter of the hose.**

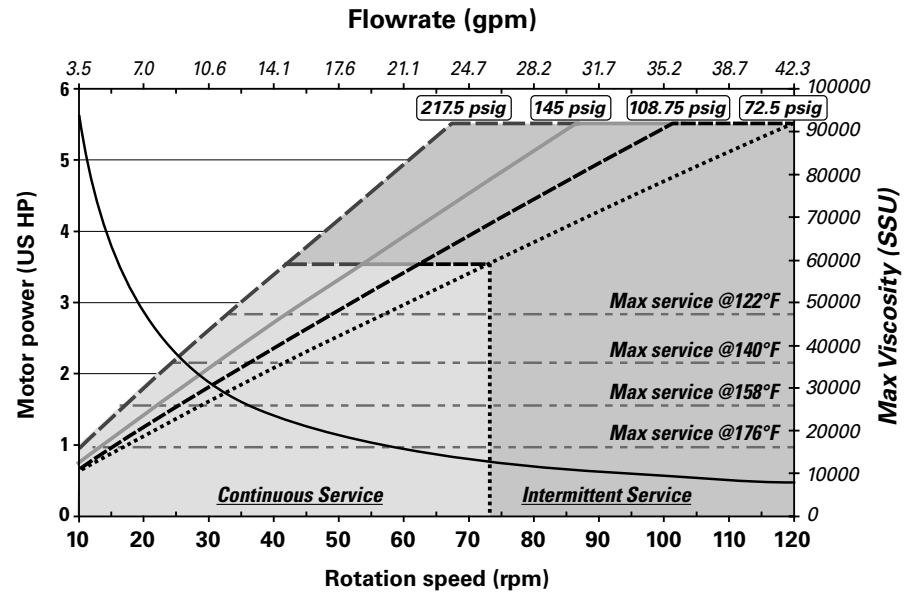

- Standard maximum product temperature is 104°F  
 - Intermittent service is 2 hours of continuous duty followed by stop of 1 hour.

## KCS65 & KSG65

Height ..... 802mm (31.6")  
 Width ..... 950mm (37.4")  
 Depth ..... 815mm (32.3")  
 Est. Ship Weight (pump only) kg (lbs)..... 244kg (538lbs)  
 Connection Type..... Flanged  
 Inlet ..... 64mm (2-1/2")  
 Discharge..... 64mm (2-1/2")  
 Suction Lift - Dry: ..... 9m (25.9')  
 Max. Viscosity @ 10 rpm ..... 40,000 cps  
 Max. Flow Rate, Intermittent - m<sup>3</sup>/h (gpm)  
 ..... 18.20 (80.13)  
 Max. Flow Rate, Constant - m<sup>3</sup>/h (gpm)  
 ..... 12.10 (53.27)  
 Max. Discharge Pressure 15 bar (217.5 psig)  
 Cylinder Capacity ..... 3.708 dm<sup>3</sup>

**Note:** Maximum solids passage is no greater than 25% of the inside diameter of the hose.

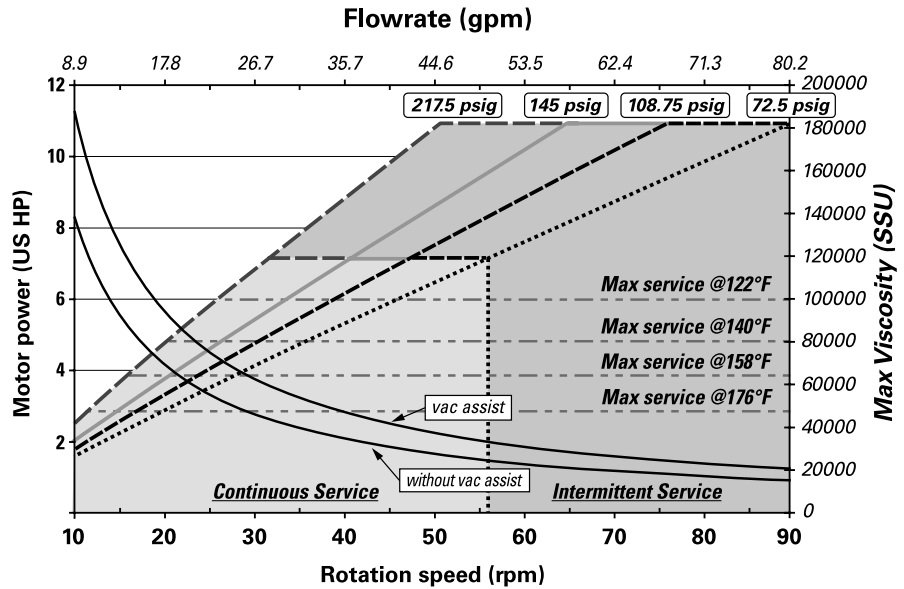

- Standard maximum product temperature is 104°F
- Intermittent service is 2 hours of continuous duty followed by stop of 1 hour.



## SUGGESTED INSTALLATION

Wilden's King Cobra™ peristaltic hose pumps are designed to meet the performance requirements of even the most demanding pumping applications. They have been designed and manufactured to the highest standards and are available in a number of different sizes to meet your pumping needs. Refer to the performance section of this manual for an in-depth analysis of the performance characteristics of your pump.

**INSTALLATION:** Months of careful planning, study, and selection efforts can result in unsatisfactory pump performance if installation details are left to chance. Premature failure and long term dissatisfaction can be avoided if reasonable care is exercised throughout the installation process.

**LOCATION:** Noise, safety, and other logistical factors usually dictate where equipment will be situated on the production floor. Multiple installations with conflicting requirements can result in congestion of utility areas, leaving few choices for additional pumps. Within the framework of these and other existing conditions, every pump should be located in such a way that the key factors are balanced against each other to maximum advantage.

**ACCESS:** First of all, the location should be accessible. If it's easy to reach the pump, maintenance personnel will have an easier time carrying out routine inspections and adjustments. Should major repairs become necessary, ease of access can play a key role in speeding the repair process and reducing total downtime.

**PIPING:** Final determination of the pump site should not be made until the piping challenges of each possible location have been evaluated. The impact of current and future installations should be considered ahead of time to make sure that inadvertent restrictions are not created for any remaining sites. The best choice possible will be a site involving the shortest and straightest hook-up of suction and discharge piping. Unnecessary elbows, bends, and fittings should be avoided. Pipe sizes should be selected to keep friction losses within practical limits. All piping should be supported independently of the pump. In addition, the piping should be aligned to avoid placing stress on the pump fittings. To eliminate possible closing of the line when performing pump maintenance, a gate valve should be installed at the suction line.

Wilden's King Cobra™ peristaltic hose pumps are positive displacement pumps; as such, care must be used in protecting piping and components used in your system. We highly suggest the use of a system relief valve.

When placing the pump, choose a location as close to the product source as possible. Care should be taken in your supply line to avoid issues due to viscosity and suction lift. **NOTE:** Some liquids may become thicker with temperature changes. Please refer to your supplier of product being pumped for information on viscosity changes due to temperature. Avoid air pockets on suction side of pump when designing piping layout. The weight of the piping should not be supported or absorbed by the pump. Suction and discharge piping should be supported by pipe hangers or another suitable means.

To mount the pump, we suggest the use of a solid, level steel base, grouted and secured to a concrete floor, sufficient enough to absorb any strain or hydraulic shock that may occur during operation. Assure pump, gear box, motor couplings and shafts are properly aligned. **NOTE:** Alignment may shift during product installation and/or product placement. Due to this, realignment could be required once the pump is mounted in the pre-selected location. We suggest a qualified technician address all alignment tasks to ensure proper installation.

**KING COBRA™ PERISTALTIC HOSE PUMPS ARE SUITED FOR PUMPING DIRTY, ABRASIVE LIQUIDS.** To ensure properly pump operation, a strainer should be used on the suction side of the pump. The strainer should consist of an adequate size mesh screen as to not cause excessive friction loss. It is suggested that a maintenance program is adhered to assure that the inlet strainer remain

### ***Pump will not start.***

1. Electric power supply:
  - a. Verify that the motor is a 3 phase type.
  - b. Ensure that the motor connections are suitable for the voltage (delta-start).
  - c. If possible, check the parameters for the different motor frequencies (starting torque, power input, etc.)

### ***Pump will start but wheel isn't turning or is struggling to turn.***

1. Pump has not been in use or hasn't been prepared for storage properly and the shoe(s) aren't appropriately lubricated which can cause resistance when the shoe(s) contacts the hose.
  - a. Operate pump intermittently to try to free the wheel. Note: Do not continue to operate the pump if wheel doesn't begin to move freely as this can damage the gear reducer.
  - b. Sediment or other substances might have collected and settled. Not allowing the shoe to compress the hose adequately.

### ***Pump runs but little product flows.***

1. The inlet or discharge valve is partially closed. Open the inlet or discharge valve.
2. Air is entering the inlet piping. Check the inlet line to ensure there is a complete seal and that air cannot be pulled into the inlet piping due to the suction generated by the pump.
3. The fluid being pumped is too viscous and creates a significant drop in pressure at the inlet of the pump. Increase the diameter of the piping to the pump.
4. The hose could be damaged. Replace the hose.

### ***Short hose life.***

1. Lubricant is not Wilden lubricant recommended for the King Cobra™ pump. Replace lubricant with genuine Wilden peristaltic hose pump lubricant.
2. Chemical incompatibility between the hose and the fluid being pumped. Replace with the hose with a hose made of a material that is suitable for the fluid being pumped.
3. Temperature of fluid being pumped is too great. Check the maximum temperature for the hose.
4. Discharge pressure too great. Check the maximum discharge pressure for the hose and decrease discharge pressure to or below the maximum recommended pressure.
5. Pump speed (rpm) is too great. Reduce pump speed.
6. Shimming of the shoe is not adequate for the application. See the section on shimming in this Engineering, Operation and Maintenance manual.

### ***Hose is pulled into the pump casing assembly at the inlet.***

1. There is an insufficient amount of lubricant. Check the amount of lubricant required. Add lubricant if needed.
2. The fluid being pumped contains solids or some type of sediment. Reverse the wheel direction and use the upper connection port as the inlet.
3. Check to ensure that the hose clamps that connect the flanges to the hose are tight. Retighten hose clamps if necessary.



**PUMP ASSEMBLY**

*KCS25 shown in photo below (Flat Pack version – no reducer and no motor)*

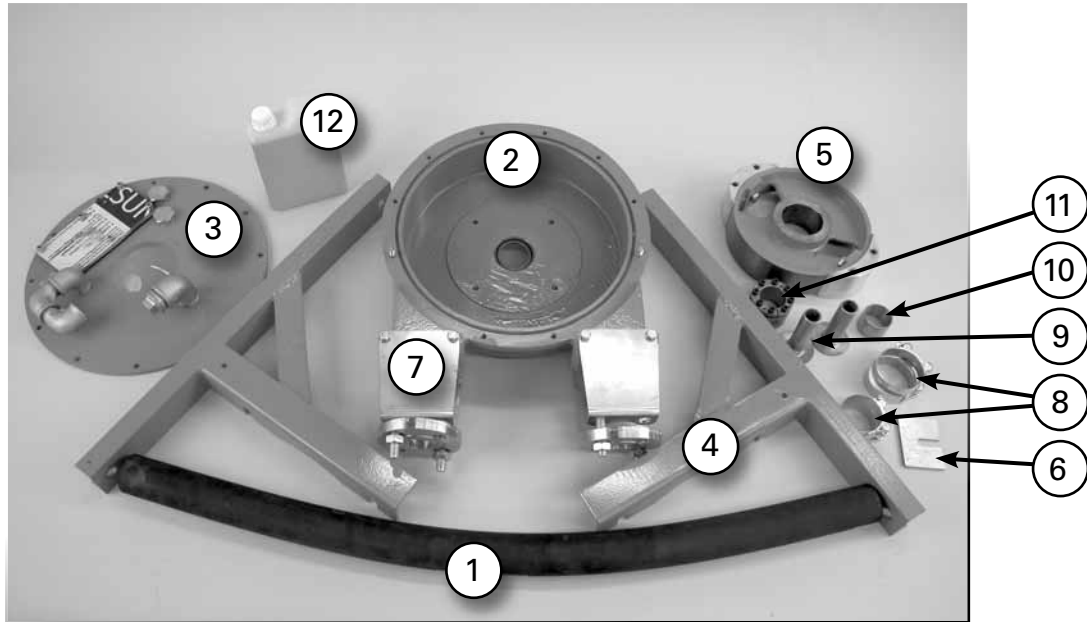

**START HERE...**

Before any repair or maintenance is attempted ensure that the pump’s electrical supply and drive has been disconnected, bleed all pressure from the pump through the suction or discharge lines and flush pump thoroughly of any hazardous fluids.

Prior to assembly, remove all parts from the shipping container the pump was provided in. Inspect parts and assemblies to ensure that all parts have been included in your shipment and that they are in acceptable condition.

*You should have received the following:*

- |                        |                                |
|------------------------|--------------------------------|
| 1. Hose                | 7. Connection Brackets & Boots |
| 2. Casing              | 8. Hose Clamps                 |
| 3. Casing Cover        | 9. Hose Insert or Barbs        |
| 4. Pump Stand Brackets | 10. Seal Ring                  |
| 5. Wheel & Shoes       | 11. Expandable Taper Lock      |
| 6. Shims               | 12. Glycerin                   |

**Note:** Pump stand brackets (base plate) are not included with the KCS10 and KCS20 pump models.

**Glycerin Capacity**

Pump	Qty.
KCS10 & KCG10	0.25 ltrs. (0.06 gal.)
KCS20 & KCG20	0.50 ltrs. (0.13 gal.)
KCS25 & KCG25	1.4 ltrs. (0.37 gal.)
KCS40 & KCG40	2.5 ltrs. (0.66 gal.)
KCSX40 & KCGX40	5.0 ltrs. (1.32 gal.)
KCS65 & KCG65	10.0 ltrs. (2.64 gal.)

## PUMP ASSEMBLY

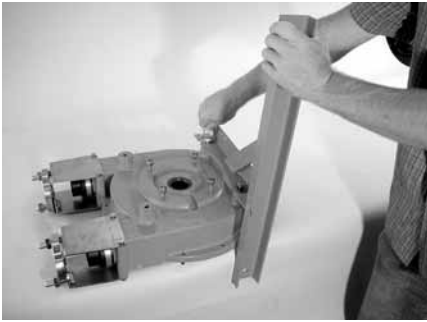

### Step 1

Using the fasteners provided, install the pump stand bracket. Please keep in mind; the 2 eye bolts provided are to be used (along with an adequate chain or equivalent) to assist in moving the pump from one location to another. CAUTION: Use a suitable lifting device capable of lifting the weight of the pump

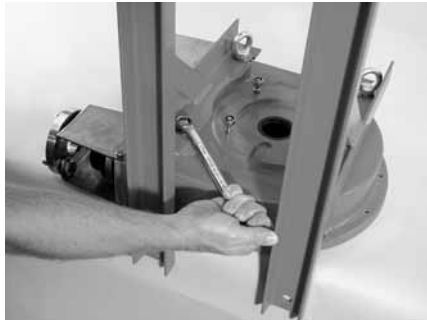

### Step 2

Again, using the fasteners provided, install the other pump stand brackets.

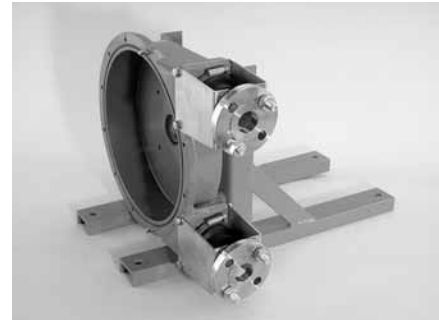

### Step 3

After installing the pump stand brackets, stand the pump in the upright position.



### Note:

Prior to connecting the gear reducer and motor to the pump head, the seal ring needs to be installed between the pump casing and the gear reducer. The seal ring needs to be installed at the area where of the casing shaft bore is located (A above).

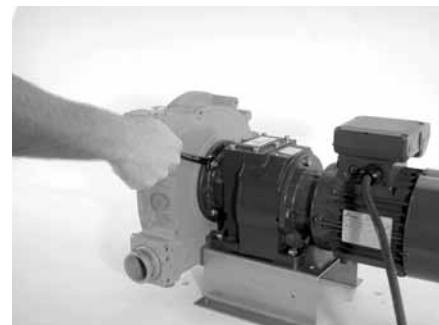
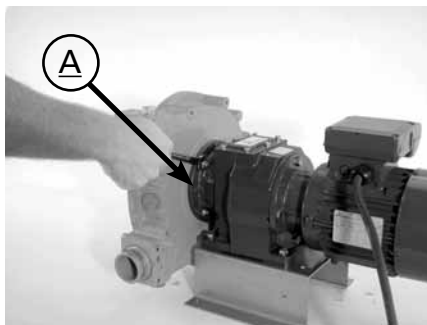

### Step 4

After installing the seal ring, tighten the fasteners connecting the pump head and gear reducer.

## SHIMMING & HOSE COMPRESSION - 25mm (1") through 65mm (2 1/2")

In regards to a peristaltic hose pump, the term "hose compression" commonly refers to a dimensional decrease at the I.D. (internal diameter) of the pump hose as the shoe rotates over the length of the hose, eventually displacing fluid through the discharge and downstream of the pump. The King Cobra™ hose

pump is set at the factory for a discharge pressure less than or equal to 5 bar (72.5 psig.) using fixed shims. To increase discharge pressure, removable non-fixed shims are positioned between the wheel and the shoe of the pump. Adding shims increases hose compression and removing shims reduces the hose compression.

### ADDING SHIMS



**Step 1**

Next, loosen the fastener that secures the shoe to the wheel. When loosening the fastener, create enough space between the shoe and the wheel so that the extra shim(s) can be installed.



**Step 2**

Now the shim(s) can be positioned between the shoe and the wheel. Tighten fastener so that wheel, shim and shoe are secure. Note: An equal amount of shims has to be installed on each shoe.

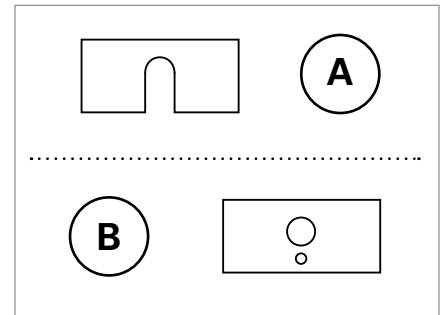

**NOTE:**

The removable shim is shim A and the fixed shim is shim B

## SETTING HOSE COMPRESSION

The King Cobra™ hose pump is set at the factory for a discharge pressure less than or equal to 5 bar (72.5 psig.) using fixed shims. Removable shims are used to increase pump discharge pressure from 5 bar (72.5 psig.) to a maximum of 15 bar (217.5 psig). Each shim that is added increases the discharge pressure. See shim table on next page for adding and removing shims.

The advantage of this type of configuration is that it enables users to easily adapt the compression of their pump hose according to the necessary differential pressure without losing the 5 bar (72.5 psig) pre-setting achieved with the use of the fixed shims. Note: The pre-setting can be used with a range of rotation speeds.

### HOSE LIFE CONSIDERATIONS:

**Too little hose compression** leads to internal leaks which lead to rapid deterioration of the hose. **Too much hose compression** puts significant internal strain on the pump as well as leading to abnormal overheating of the hose which greatly reduces operational life.

<sup>a</sup>Hose compression is measured between the top of the shoe and the internal diameter of the pump casing

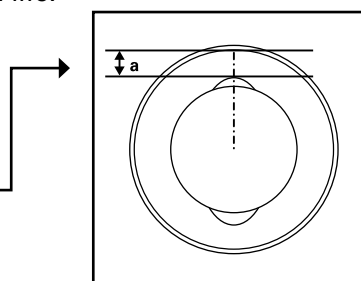

## HOSE COMPRESSION TABLES

The tables below should be used for setting the hose compression on your King Cobra™ pump for any given application. The critical factors for setting the hose compression on your King Cobra™ pump are included in these tables and are as follows: rotation speed, desired discharge pressure and how many removable shims are needed for a specific discharge pressure range.

### *How to use the hose compression tables – as simple as 1, 2, 3....*

1. Choose the desired discharge pressure range in the Discharge Pressure column.
2. Next, choose the revolutions per minute (RPM) range that achieves your desired flow rate. See performance section of this manual for RPM and flow rate information.
3. After completing steps 1 and 2, choose the total quantity of shims needed to coincide with the desired discharge pressure and RPM range.

### KCS25 & KCSG25

Discharge Pressure bar (psig)	RPM Range	Total Shims Needed (removable)
5 (73) to 7.5 (108.7)	5 to 40	1
	41 to 120	2
	121 to 135	3
7.5 (108.7) to 10 (145)	5 to 40	1
	40 to 115	2
10 (145) to 15 (217.5)	5 to 40	1
	40 to 90	2

### KCS40 & KCSG40

Discharge Pressure bar (psig)	RPM Range	Total Shims Needed (removable)
5 (73) to 7.5 (108.7)	5 to 45	1
	45 to 115	2
7.5 (108.7) to 10 (145)	5 to 45	1
	45 to 100	2
10 (145) to 15 (217.5)	5 to 45	1
	45 to 75	2

### KCSX40 & KCSGX40

Discharge Pressure bar (psig)	RPM Range	Total Shims Needed (removable)
5 (73) to 7.5 (108.7)	5 to 55	1
	55 to 100	2
7.5 (108.7) to 10 (145)	5 to 55	1
	55 to 85	2
10 (145) to 15 (217.5)	85 to 55	1
	55 to 65	2

### KCS65 & KCSG65

Discharge Pressure bar (psig)	RPM Range	Total Shims Needed (removable)
5 (73) to 7.5 (108.7)	5 to 30	1
	41 to 65	2
	30 to 75	3
7.5 (108.7) to 10 (145)	5 to 30	1
	30 to 65	2
10 (145) to 15 (217.5)	5 to 30	1
	30 to 50	2

## INSTALLING THE WHEEL



### Step 1

Prior to installing the expandable taper lock, ensure that the cut-away area is offset. This allows the expandable taper lock to distribute even force onto the shaft and casing bore at the same time.



### Step 2

Position the tape lock at the wheel shaft bore. Using a socket and rubber mallet, gently press the expandable taper lock into the center shaft bore on the wheel.



### Step 3

Next, install the wheel onto the reducer shaft.



### Step 4

With a hex head wrench lightly torque the fasteners located on the front of the expandable taper lock in a star pattern. This will distribute force to the gear reducer shaft and wheel bore. This secures the wheel to the pump.

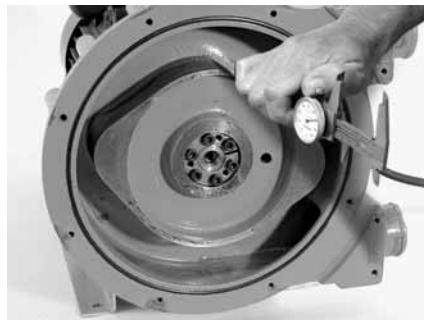

### Step 5

Using a pair of calipers or other equivalent measuring device, measure the distance from the outer edge of the wheel to the back of the casing. This will ensure that the wheel doesn't come into contact with the casing as it is rotating during pump operation.

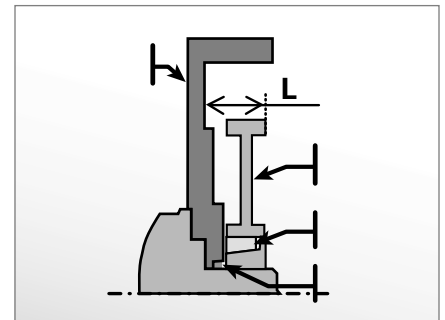

### Note:

After aligning the wheel gradually torque the expandable taper lock until tight. Use caution to not interfere with the alignment of the wheel. See diagram above for example.



### Step 6

Now the pump casing cover can be installed. Note: Use caution when tightening the casing cover fasteners. Over tightening the fasteners could cause damage to the casing cover

## INSTALLING THE HOSE

The hose is the heart of the peristaltic hose pump. The hose is resistant to high pressures, cyclic compressions, highly abrasive and aggressive fluids. The durable hose design consists of multiple layers of rubber material and weaves of synthetic fiber. The pump hose is available in three materials to satisfy your application needs; natural rubber (NR), Buna-N (BN) and EPDM (EP).

### **Cleaning the hose:**

Some pumped fluids require the hose to be cleaned after each operation to prevent solidification of the fluid inside the hose. The hose can be easily washed with a cleaning agent that is compatible with the hose material and the pumped fluid.

### **Replacing the hose:**

The hose of the pump is a wear item and should be replaced after 2,000 hours of operation. When replacing the hose, it is suggested that the Wilden glycerin should be replaced as well. Wilden suggests the use of a maintenance schedule so that unwanted hose failure are reduced.

### **Lubricant:**

The hose lubricant is recommended to lengthen the service life of the hose. The minimum working or storage temperature for the pump lubricant is -20°C (-4°F). If the temperature is lower than -20°C (-4°F), 5% ethylene glycol may be added to the Wilden lubricant.



**Step 1**

Using the Wilden glycerin provided and a clean brush (not provided), apply glycerin to entire length of the pump hose

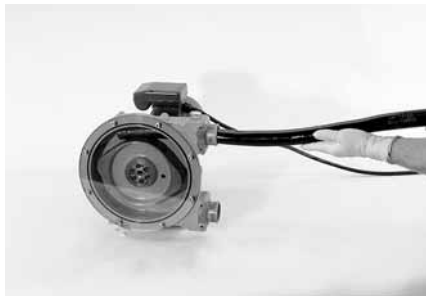

**Step 2**

After coating the hose with glycerin, insert either end of the hose into the inlet of the pump. To draw the hose into the pump, turn power to on pump on. The rotation of the wheel will gently pull the hose into the casing.



**Step 3**

Use caution when installing the hose. When pump is running keep hands and clothing away from moving parts.



**Step 4**

When the hose installation process is complete, both ends of the hose should protrude from the inlet and discharge ports of the pump.



**Step 5**

Next, add Wilden glycerin into pump casing.

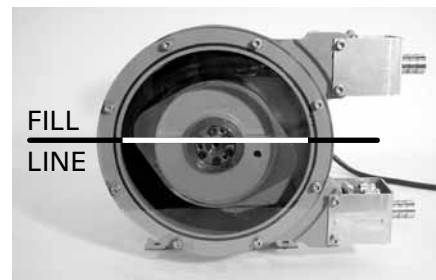

**Step 6**

Fill pump with glycerin until the glycerin level is just above the shaft and expandable tape lock.

**FINAL ASSEMBLY**



**Step 1**

First, insert the hose barb or hose insert into each end of the protruding hose.



**Step 2**

Next, install the boot onto both ends of the protruding hose.

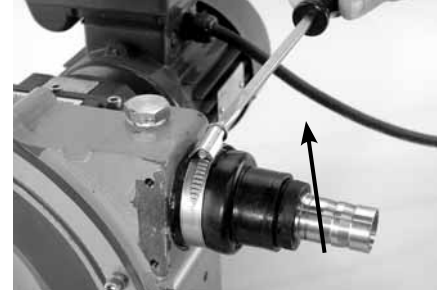

**Step 3**

Install the larger of the two sizes of hose clamps onto each boot.

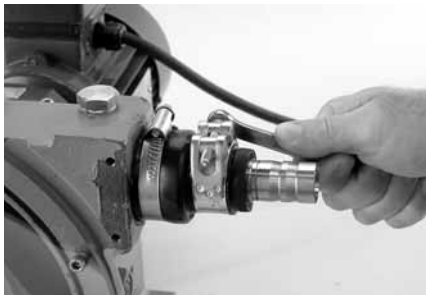

**Step 4**

Now the smaller of the two sizes of hose clamps can be installed at each end of the protruding hose.

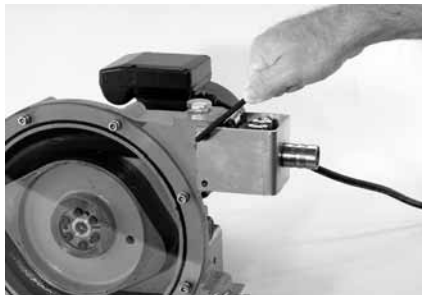

**Step 5**

Next, install a bracket at each end of the hose.

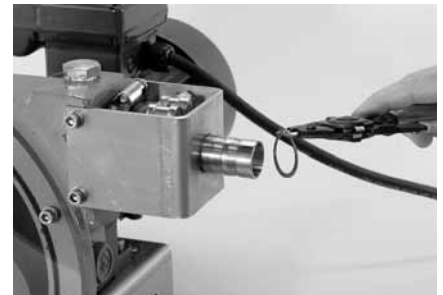

**Note:**

Install the snap ring that secures the hose barb to the bracket. This is for 10mm (3/8") and 19mm (3/4") only. The King Cobra™ pumps that have flanged inlet and discharge connections are slightly different by design and do not require a snap ring.



## REPLACEMENT PARTS

## KCS40 &amp; KCG40

PART DESCRIPTION	ITEM NO.
HOSE, KC40, NR	218727
HOSE, KC40, NBR	218728
HOSE, KC40, EPDM	218729
INSERTS, KC40, STAINLESS STEEL	217310
INSERTS, KC40, PPH	217311
INSERTS, KC40, PVDF	217312
BOOT/CLAMP, KC40	312780.00
COVER SEAL, VT, KC40	220201
LUBRICANT, GLYCERIN, KC40 / KCX40	314222.00
WINDOW, POLYCARBONATE, KC40	220209
SHOE SHIMS, 6 PCS, KC40	312358.00
SHAFT SEAL/BUSHING, Ø 40, KC40	313030.00
SHAFT SEAL/BUSHING, Ø 50, KC40 / KCX40	313033.00

## KCSX40 &amp; KCGX40

PART DESCRIPTION	ITEM NO.
HOSE, KCX40, NR	218730
HOSE, KCX40, NBR	218731
HOSE, KCX40, EPDM	218732
INSERTS, KCX40, STAINLESS STEEL	217313
INSERTS, KCX40, PPH	217314
INSERTS, KCX40, PVDF	217315
BOOT/CLAMP, KCX40	312745.00
COVER SEAL, VT, KCX40	220144
LUBRICANT, GLYCERIN, KC40 / KCX40	314222.00
WINDOW, POLYCARBONATE, KCX40	220143
WINDOW, SEAL, EPDM, KCX40	217396
SHOE SHIMS, 6 PCS, KCX40	312359.00
SHAFT SEAL/BUSHING, Ø 48, KCX40	313032.00
SHAFT SEAL/BUSHING, Ø 50, KC40 / KCX40	313033.00

## KCS65 &amp; KCG65

PART DESCRIPTION	ITEM NO.
HOSE, KC65, NR	218736
HOSE, KC65, NBR	218737
HOSE, KC65, EPDM	218738
INSERTS, KC65, STAINLESS STEEL	217319
INSERTS, KC65, PPH	217320
INSERTS, KC65, PVDF	217321
BOOT/CLAMP, KC65	312735.00
COVER SEAL, VT, KC65	220117
LUBRICANT, GLYCERIN, KC65	314223.00
WINDOW, POLYCARBONATE, KC65	220119
WINDOW, SEAL, EPDM, KC65	217397
SHOE SHIMS, 6 PCS, KC65	312360.00
SHAFT SEAL/BUSHING, Ø 55, KC65	313041.00
SHAFT SEAL/BUSHING, Ø 60, KC65	313042.00

# WARRANTY

Each and every product manufactured by Wilden Pump and Engineering, LLC is built to meet the highest standards of quality. Every pump is functionally tested to insure integrity of operation.

Wilden Pump and Engineering, LLC warrants that pumps, accessories and parts manufactured or supplied by it to be free from defects in material and workmanship for a period of two (2) years from date of installation or three (3) years from date of manufacture, whichever comes first. Failure due to normal wear, misapplication, or abuse is, of course, excluded from this warranty.

Since the use of Wilden pumps and parts is beyond our control, we cannot guarantee the suitability of any pump or part for a particular application and Wilden Pump and Engineering, LLC shall not be liable for any consequential damage or expense arising from the use or misuse of its products on any application. Responsibility is limited solely to replacement or repair of defective Wilden pumps and parts.

All decisions as to the cause of failure are the sole determination of Wilden Pump and Engineering, LLC.

Prior approval must be obtained from Wilden for return of any items for warranty consideration and must be accompanied by the appropriate MSDS for the product(s) involved. A Return Goods Tag, obtained from an authorized Wilden distributor, must be included with the items which must be shipped freight prepaid.

The foregoing warranty is exclusive and in lieu of all other warranties expressed or implied (whether written or oral) including all implied warranties of merchantability and fitness for any particular purpose. No distributor or other person is authorized to assume any liability or obligation for Wilden Pump and Engineering, LLC other than expressly provided herein.

**PLEASE PRINT OR TYPE AND FAX TO WILDEN**

PUMP INFORMATION			
Item # _____		Serial # _____	
Company Where Purchased _____			
YOUR INFORMATION			
Company Name _____			
Industry _____			
Name _____		Title _____	
Street Address _____			
City _____	State _____	Postal Code _____	Country _____
Telephone _____	Fax _____	E-mail _____	Web Address _____
Number of pumps in facility? _____		Number of Wilden pumps? _____	
Types of pumps in facility (check all that apply): <input type="checkbox"/> Diaphragm <input type="checkbox"/> Centrifugal <input type="checkbox"/> Gear <input type="checkbox"/> Submersible <input type="checkbox"/> Lobe			
<input type="checkbox"/> Other _____			
Media being pumped? _____			
How did you hear of Wilden Pump? <input type="checkbox"/> Trade Journal <input type="checkbox"/> Trade Show <input type="checkbox"/> Internet/E-mail <input type="checkbox"/> Distributor			
<input type="checkbox"/> Other _____			

**ONCE COMPLETE, FAX TO (909) 783-3440**

NOTE: WARRANTY VOID IF PAGE IS NOT FAXED TO WILDEN

WILDEN PUMP & ENGINEERING, LLC

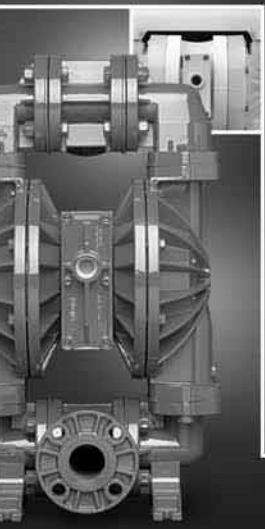

## **ADVANCED** S E R I E S

### **Advance Your Process**

- Advanced wetted path designs
- Lower the cost of operation
- Maximize product containment
- Longer MTBF (Mean Time Between Failures)
- Enhanced internal clearance
- The result of advanced thought

## **UNITEC** B E R I E S

### **Enrich Your Process**

- Simplicity of design
- Unique Technology
- Reliable, leak-free & quiet
- Validated & certified
- Intrinsically safe
- The result of unique thought

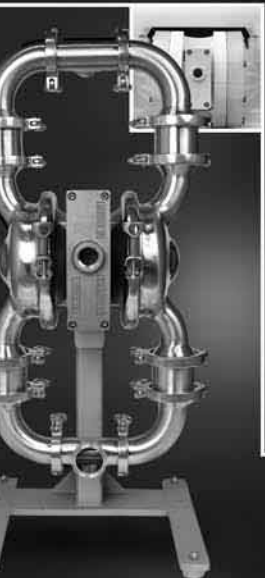
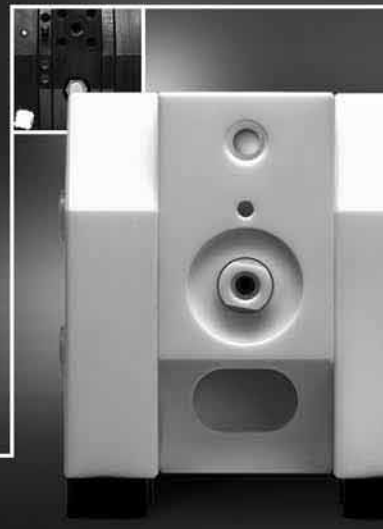

## **SANIFLO** S A N I T A R Y P U M P T E C H N O L O G Y

### **Refine Your Process**

- Designed for sanitary applications
- Minimize product degradation
- Improved production yields
- Easy to inspect, clean & assemble
- Minimized water requirements
- The result of progressive thought

## **ACCESSORIES**

### **Maximize Your Process**

- Electronic control & monitoring
- Level control & containment
- Pulsation dampening
- Drum unloading systems
- Complete system solutions
- The result of innovative thought

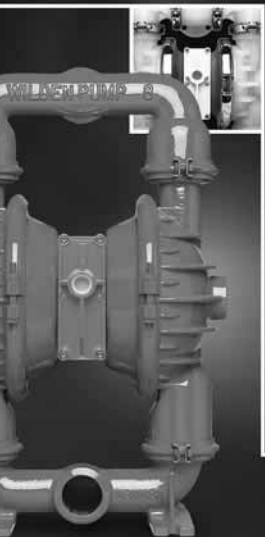

## **ORIGINAL** S E R I E S

### **Simplify Your Process**

- Long standing design simplicity
- Portable & submersible
- Variable connection options
- Fewest parts in industry
- Solutions since 1955
- The result of original thought



# **WILDEN**<sup>®</sup>

A **DOVER** COMPANY

22069 VAN BUREN STREET • GRAND TERRACE, CA 92313-5607  
(909) 422-1730 • FAX (909) 783-3440  
www.wildenpump.com

Your Local Authorized Distributor: