

H200

Advanced™ Series **METAL** Pumps

EOM

Engineering
Operation &
Maintenance



Advance your process

4800
HIGH PRESSURE PUMP



WILDEN®

A **DOVER** COMPANY

WIL-11190-E-02
REPLACES WIL-11190-E-01

TABLE OF CONTENTS

SECTION 1 CAUTIONS—READ FIRST!1

SECTION 2 WILDEN PUMP DESIGNATION SYSTEM2

SECTION 3 HOW IT WORKS—PUMP & AIR DISTRIBUTION SYSTEM3

SECTION 4 DIMENSIONAL DRAWINGS4

SECTION 5 PERFORMANCE5

SECTION 6 SUGGESTED INSTALLATION, OPERATION & TROUBLESHOOTING6

SECTION 7 ASSEMBLY / DISASSEMBLY9

SECTION 8 EXPLODED VIEW & PARTS LISTING

 Wetted Path18

 Center Section20

CAUTIONS—READ FIRST!



TEMPERATURE LIMITS:

Neoprene	-17.7°C to 93.3°C	0°F to 200°F
Buna-N	-12.2°C to 82.2°C	10°F to 180°F
Nordel®	-51.1°C to 137.8°C	-60°F to 280°F
Viton®	-40°C to 176.7°C	-40°F to 350°F
Saniflex™	-28.9°C to 104.4°C	-20°F to 220°F
Wil-Flex™	-40°C to 107.2°C	-40°F to 225°F
Polytetrafluoroethylene (PTFE)	4.4°C to 104.4°C	40°F to 220°F
Polyurethane	-12.2°C to 65.6°C	10°F to 150°F

NOTE: Not all materials are available for all models. Refer to Section 2 for material options for your pump.



CAUTION: When choosing pump materials, be sure to check the temperature limits for all wetted components. Example: Viton® has a maximum limit of 176.7°C (350°F) but polypropylene has a maximum limit of only 79°C (175°F).



CAUTION: Maximum temperature limits are based upon mechanical stress only. Certain chemicals will significantly reduce maximum safe operating temperatures. Consult Chemical Resistance Guide (E4) for chemical compatibility and temperature limits.



WARNING: Prevention of static sparking — If static sparking occurs, fire or explosion could result. Pump, valves, and containers must be grounded to a proper grounding point when handling flammable fluids and whenever discharge of static electricity is a hazard.



CAUTION: Do not exceed 5.9 bar (100 psi) air supply pressure.



CAUTION: All piping, valves, gauges and other components installed on the liquid discharge must have a minimum pressure rating of 20.7 bar (300 psig).



CAUTION: The discharge pressure generated by this pump is 3X the inlet pressure supplied.



CAUTION: The process fluid and cleaning fluids must be chemically compatible with all wetted pump components. Consult Chemical Resistance Guide (E4).



CAUTION: Pumps should be thoroughly flushed before installing into process lines. FDA and USDA approved pumps should be cleaned and/or sanitized before being used.



CAUTION: Always wear safety glasses when operating pump. If diaphragm rupture occurs, material being pumped may be forced out air exhaust.



CAUTION: Before any maintenance or repair is attempted, the compressed air line to the pump should be disconnected and all air pressure allowed to bleed from pump. Disconnect all intake, discharge and air lines. Drain the pump by turning it upside down and allowing any fluid to flow into a suitable container.



CAUTION: Blow out air line for 10 to 20 seconds before attaching to pump to make sure all pipeline debris is clear. Use an in-line air filter. A 5µ (micron) air filter is recommended.



NOTE: Before starting disassembly, mark a line from each liquid chamber to its corresponding air chamber. This line will assist in proper alignment during reassembly.



CAUTION: Wilden H200 High Pressure pumps cannot be used in submersible applications.



CAUTION: Re-torque all hardware prior to installation.



WILDEN PUMP DESIGNATION SYSTEM

H200 METAL

25 mm (1") Pump
Maximum Flow Rate:
94 lpm (25 gpm)

LEGEND

H200 / XXXXX / XXX / XX / XXX / XXXX

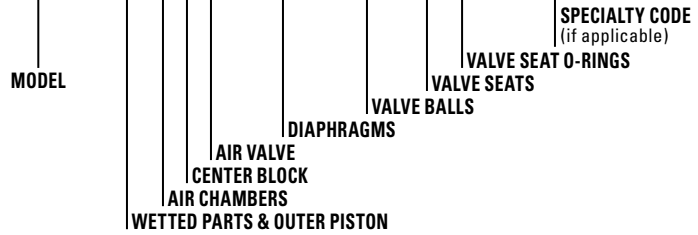

MATERIAL CODES

MODEL

H200 = 25 mm (1") HIGH PRESSURE (NPT no specialty code)

WETTED PARTS & OUTER PISTON

WW = DUCTILE IRON/ DUCTILE IRON

AIR CHAMBERS

W = DUCTILE IRON

CENTER BLOCK

A = ALUMINUM

AIR VALVE

A = ALUMINUM

DIAPHRAGMS

FWS = WIL-FLEX™ Food-Grade [Santoprene® (Two Orange Dots)]

VALVE BALL

WF = WIL-FLEX™ [Santoprene® (Orange Dot)]

VALVE SEAT

M = MILD STEEL

VALVE SEAT O-RING

WF = WIL-FLEX™ [Santoprene® (Orange Dot)]

SPECIALTY CODES

None NPT Connection
0014 BSPT Connection

NOTE: MOST ELASTOMERIC MATERIALS USE COLORED DOTS FOR IDENTIFICATION.

NOTE: Not all models are available with all material options.

Teflon® is a registered trademark of DuPont.

The Wilden diaphragm pump is an air-operated, positive displacement, self-priming pump. These drawings show flow pattern through the pump upon its initial stroke. It is assumed the pump has no fluid in it prior to its initial stroke.

Preface: The H200 uses an integral power amplifier piston together with two diaphragms to yield a pressure ratio of 3:1 (e.g. 100psig air inlet will develop liquid discharge pressures up to 300 psig). In the H200 air is simultaneously directed behind the amplifier piston a well as one of the diaphragms via specialized air manifold porting. The sum of the two surface areas is three times that of the diaphragm alone. Therefore, the discharge is amplified by a 3:1 pressure output ratio.

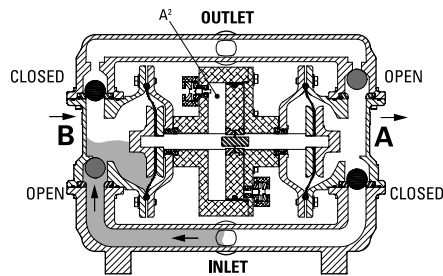

Figure 1 When air pressure is supplied to the pump, the air valve directs pressure to the back side of diaphragm (A). The compressed air moves the diaphragm away from the center section of the pump. Simultaneously, compressed air is also supplied to the back side of the power piston (A2); pressure on Area A2 exerts force on the shaft communicated to diaphragm A. This force, when added to the force of pressure A is connected to the process fluid, thus providing the increase of liquid output pressure.

During this operation the opposite diaphragm (diaphragm B) is pulled in by a shaft connected to the power piston (A2) and pressurized diaphragm (A). Diaphragm (B) is now on its suction stroke; air behind diaphragm (B) and piston (B2) is being forced out to atmosphere through the exhaust port. The movement of diaphragm (B) towards the center section of the pump creates a vacuum within chamber (B). Atmospheric pressure forces fluid into the inlet manifold forcing the inlet valve ball off its seat. Liquid is free to move past the inlet valve ball and fill the liquid chamber (see shaded area).

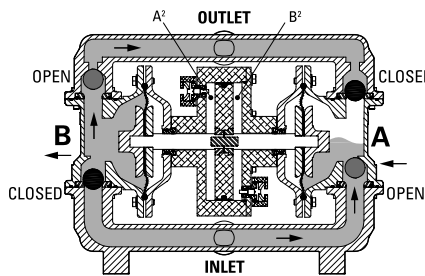

Figure 2 Once the power piston reaches the end of its stroke, the pressure relief valve opens. This causes the air valve to shift. This action redirects pressurized air to the back side (air side) of diaphragm (B) as well as the back side of the power piston (B2). This pressurized air forces diaphragm (B) away from the center section while also pulling diaphragm (A) towards the center section. Diaphragm (B) is now on its discharge stroke. Diaphragm (B) forces the inlet valve ball onto its seat due to the hydraulic forces developed in the liquid chamber and manifold. The same hydraulic force unseats the discharge valve ball of its seat and forces fluid to flow through the pump discharge.

The pressure on the diaphragm (B) creates a force that is combined with the force of pressure applied to the power piston (B2). This total load is transferred to the liquid creating a liquid pressure that is 3 times the supplied air pressure.

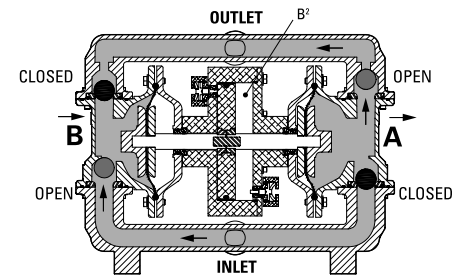
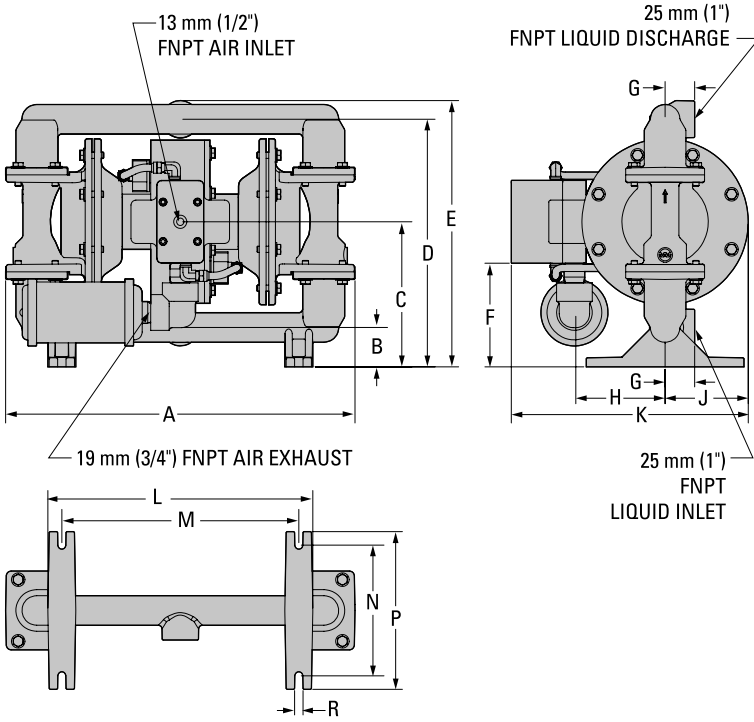

Figure 3 At the completion of the stroke, once again the pressure relief valve opens and shifts the air valve. The air valve redirects air to the back side of diaphragm (A) and the power piston (A2), the air behind diaphragm (B) and the power piston (B2) is now exhausted. As the pump reaches its original starting position, each diaphragm has gone through one suction and one discharge stroke of the wetted path and one pressure and exhaust stroke of the air distribution system. This completes one cycle of the high pressure H200. Note: The pump may take several cycles to completely prime depending on the condition of the application.

DIMENSIONAL DRAWINGS

H200 Metal



DIMENSIONS

ITEM	METRIC (mm)	STANDARD (inch)
A	450	17.7
B	51	2.0
C	188	7.4
D	320	12.6
E	343	13.5
F	135	5.3
G	38	1.5
H	114	4.5
J	107	4.2
K	305	12.0
L	340	13.4
M	295	11.6
N	168	6.6
P	203	8.0
R	10	0.4

SUGGESTED INSTALLATION

Wilden pumps are designed to meet the performance requirements of even the most demanding pumping applications. They have been designed and manufactured to the highest standards and are available in a variety of liquid path materials to meet your chemical resistance needs. Refer to the performance section of this manual for an in-depth analysis of the performance characteristics of your pump. Wilden offers the widest variety of elastomer options in the industry to satisfy temperature, chemical compatibility, abrasion resistance and flex concerns.

The suction pipe size should be at least the equivalent or larger than the diameter size of the suction inlet on your Wilden pump. The suction hose must be non-collapsible, reinforced type as these pumps are capable of pulling a high vacuum. Discharge piping should also be the equivalent or larger than the diameter of the pump discharge which will help reduce friction losses. It is critical that all fittings and connections are airtight or a reduction or loss of pump suction capability will result.

INSTALLATION: Months of careful planning, study, and selection efforts can result in unsatisfactory pump performance if installation details are left to chance.

Premature failure and long term dissatisfaction can be avoided if reasonable care is exercised throughout the installation process.

LOCATION: Noise, safety, and other logistical factors usually dictate where equipment will be situated on the production floor. Multiple installations with conflicting requirements can result in congestion of utility areas, leaving few choices for additional pumps.

Within the framework of these and other existing conditions, every pump should be located in such a way that six key factors are balanced against each other to maximum advantage.

ACCESS: First of all, the location should be accessible. If it's easy to reach the pump, maintenance personnel will have an easier time carrying out routine inspections and adjustments. Should major repairs become necessary, ease of access can play a key role in speeding the repair process and reducing total downtime.

AIR SUPPLY: Every pump location should have an air line large enough to supply the volume of air necessary to achieve the desired pumping rate. Use air pressure up to a maximum of 6.9 bar (100 psig) depending on pumping requirements.

For best results, the pumps should use a 5 μ (micron) air filter, needle valve and regulator. The use of an air filter before the pump will ensure that the majority of any pipeline contaminants will be eliminated.

SOLENOID OPERATION: When operation is controlled by a solenoid valve in the air line, three-way valves should be used. This valve allows trapped air between the valve and the pump to bleed off which improves pump performance. Pumping volume can be estimated by counting the number of strokes per minute and then multiplying the figure by the displacement per stroke.

MUFFLER: Sound levels are reduced below OSHA specifications using the standard Wilden muffler. Other mufflers can be used to further reduce sound levels, but they usually reduce pump performance.

ELEVATION: Selecting a site that is well within the pump's dynamic lift capability will assure that loss-of-prime issues will be eliminated. In addition, pump efficiency can be adversely affected if proper attention is not given to site location.

PIPING: Final determination of the pump site should not be made until the piping challenges of each possible location have been evaluated. The impact of current and future installations should be considered ahead of time to make sure that inadvertent restrictions are not created for any remaining sites.

The best choice possible will be a site involving the shortest and straightest hook-up of suction and discharge piping. Unnecessary elbows, bends, and fittings should be avoided. Pipe sizes should be selected to keep friction losses within practical limits. All piping should be supported independently of the pump. In addition, the piping should be aligned to avoid placing stress on the pump fittings.

Flexible hose can be installed to aid in absorbing the forces created by the natural reciprocating action of the pump. If the pump is to be bolted down to a solid location, a mounting pad placed between the pump and the foundation will assist in minimizing pump vibration. Flexible connections between the pump and rigid piping will also assist in minimizing pump vibration. If quick-closing valves are installed at any point in the discharge system, or if pulsation within a system becomes a problem, a surge suppressor (SD Equalizer[®]) should be installed to protect the pump, piping and gauges from surges and water hammer.

If the pump is to be used in a self-priming application, make sure that all connections are airtight and that the suction lift is within the model's ability. Note: Materials of construction and elastomer material have an effect on suction lift parameters. Please refer to the performance section for specifics.

When pumps are installed in applications involving flooded suction or suction head pressures, a gate valve should be installed in the suction line to permit closing of the line for pump service.

Pumps in service with a positive suction head are most efficient when inlet pressure is limited to 0.5–0.7 bar (7–10 psig). Premature diaphragm failure may occur if positive suction is 0.7 bar (10 psig) and higher.

ALL WILDEN PUMPS ARE CAPABLE OF PASSING SOLIDS. A STRAINER SHOULD BE USED ON THE PUMP INTAKE TO ENSURE THAT THE PUMP'S RATED SOLIDS CAPACITY IS NOT EXCEEDED.

CAUTION: DO NOT EXCEED 6.9 BAR (100 PSIG) AIR SUPPLY PRESSURE.

SUGGESTED INSTALLATION

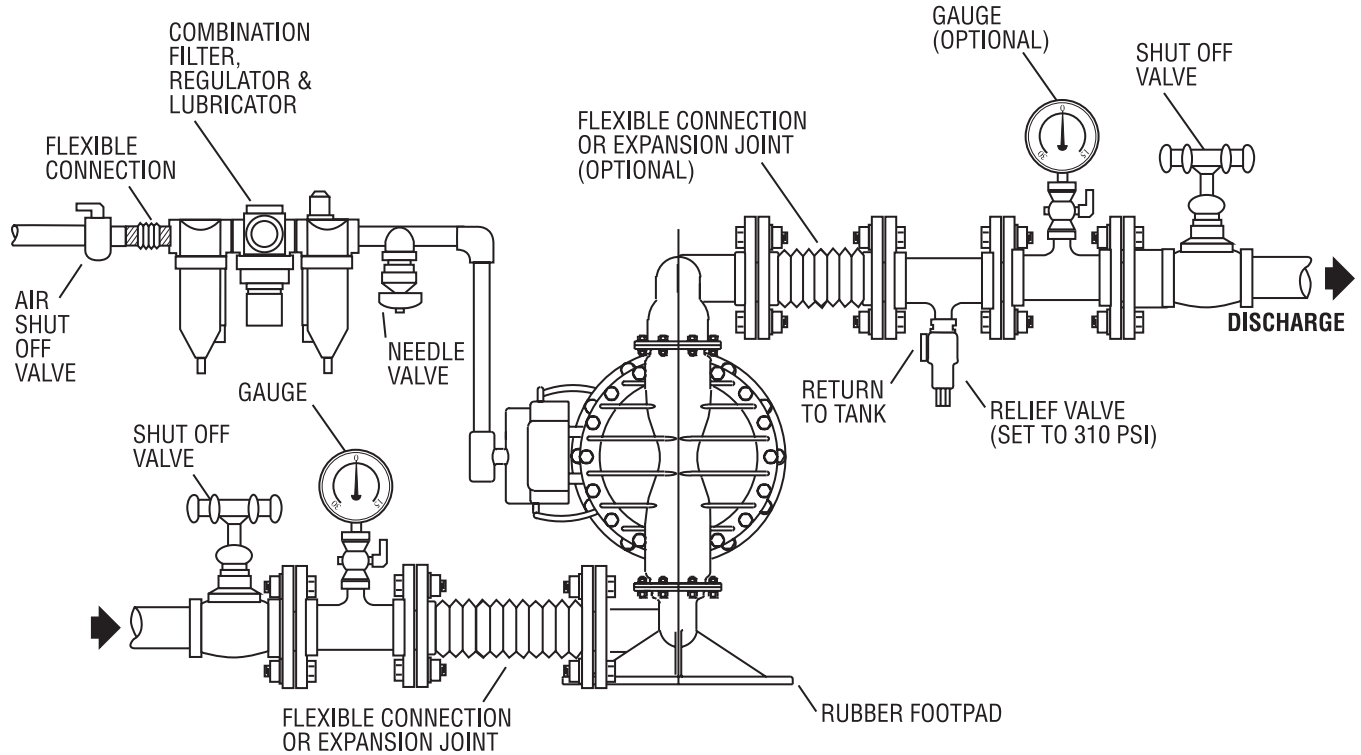

NOTE: In the event of a power failure, the shut off valve should be closed, if the restarting of the pump is not desirable once power is regained.

AIR OPERATED PUMPS: To stop the pump from operating in an emergency situation, simply close the

shut off valve (user supplied) installed in the air supply line. A properly functioning valve will stop the air supply to the pump, therefore stopping output. This shut off valve should be located far enough away from the pumping equipment such that it can be reached safely in an emergency situation.

SUGGESTED OPERATION & MAINTENANCE

OPERATION: Pump discharge rate can be controlled by limiting the volume and/or pressure of the air supply to the pump. An air regulator is used to regulate air pressure. A needle valve is used to regulate volume. Pump discharge rate can also be controlled by throttling the pump discharge by partially closing a valve in the discharge line of the pump. This action increases friction loss which reduces flow rate. (See Section 5.) This is useful when the need exists to control the pump from a remote location. When the pump discharge pressure equals or exceeds the air supply pressure, the pump will stop; no bypass or pressure relief valve is needed, and pump damage will not occur. The pump has reached a "deadhead" situation and can be restarted by reducing the fluid discharge pressure or increasing the air inlet pressure. The Wilden H200 pump runs solely on compressed air and does not generate heat, therefore your process fluid temperature will not be affected.

MAINTENANCE AND INSPECTIONS: Since each application is unique, maintenance schedules may be different for every pump. Frequency of use, line pressure, viscosity and abrasiveness of process fluid all affect the parts life of a Wilden pump. Periodic inspections have been found to offer the best means for preventing unscheduled pump downtime. Personnel familiar with the pump's construction and service should be informed of any abnormalities that are detected during operation.

RECORDS: When service is required, a record should be made of all necessary repairs and replacements. Over a period of time, such records can become a valuable tool for predicting and preventing future maintenance problems and unscheduled downtime. In addition, accurate records make it possible to identify pumps that are poorly suited to their applications.

TROUBLESHOOTING

Pump will not run or runs slowly.

1. With the use of the flow curve located in the performance section of this EOM, verify air pressure and volume required for your application. If inlet air pressure is too low, the H200 pump will not operate.
2. Check air inlet filter for debris (see recommended installation).
3. Disassemble pump and check for obstructions in the air passageways or objects which would obstruct the movement of internal parts.
4. Check for sticking ball check valves. If material being pumped is not compatible with pump elastomers, swelling may occur. Replace ball check valves and seals with proper elastomers. Also, as the check valve balls wear out, they become smaller and can become stuck in the seats. In this case, replace balls and seats.
5. Inspect pressure relief valve for damage. Replace if necessary with genuine Wilden parts.
6. Inspect the center block seals for damage. Replace if necessary.

Pump runs but little or no product flows.

1. Check for pump cavitation; slow pump speed down to allow thick material to flow into liquid chambers.
2. Verify that vacuum required to lift liquid is not greater than the vapor pressure of the material being pumped (cavitation).

3. Check for sticking ball check valves. If material being pumped is not compatible with pump elastomers, swelling may occur. Replace ball check valves and seats with proper elastomers. Also, as the check valve balls wear out, they become smaller and can become stuck in the seats. In this case, replace balls and seats.
4. Check tightness of inlet and discharge connections.
5. Check tightness of all fasteners.

Pump air valve freezes.

1. Check for excessive moisture in compressed air. Either install a dryer or hot air generator for compressed air. Alternatively, a coalescing filter may be used to remove the water from the compressed air in some applications.

Air bubbles in pump discharge.

1. Check for ruptured diaphragm.
2. Check tightness of outer pistons (refer to Section 7).
3. Check tightness of fasteners and integrity of o-rings and seals, especially at intake manifold.
4. Ensure pipe connections are airtight.

Product comes out air exhaust.

1. Check for diaphragm rupture.
2. Check tightness of outer pistons to shaft.
3. Check tightness of fasteners that connect the inner piston to the outer piston.

PUMP DISASSEMBLY

Tools Required

- 1/2" Wrench
- 9/16" Wrench
- 3/4" Wrench
- 1" Wrench
- 15/16" Wrench
- 5/64" Hex Head Wrench
- 3/16" Hex Head Wrench
- O-ring Pick
- Adjustable Wrench
- Snap Ring Pliers
- 5/8"-18 Jam Nut
- 1/2" Socket
- 1" Socket
- Torque Wrench

CAUTION: Before any maintenance or repair is attempted, the compressed air line to the pump should be disconnected and all air pressure allowed to bleed from the pump. Disconnect all intake, discharge, and air lines. Drain the pump by turning it upside down and allowing any fluid to flow into a suitable container. Be aware of any hazardous effects of contact with your process fluid.

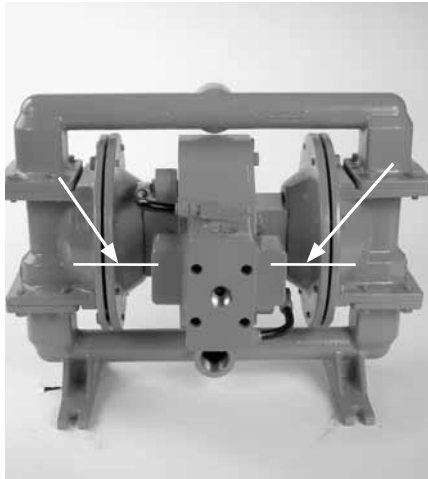

Step 1

Put alignment marks on liquid chambers and air chambers. Use these marks to properly align the liquid chambers (center section) to the air chambers during reassembly.

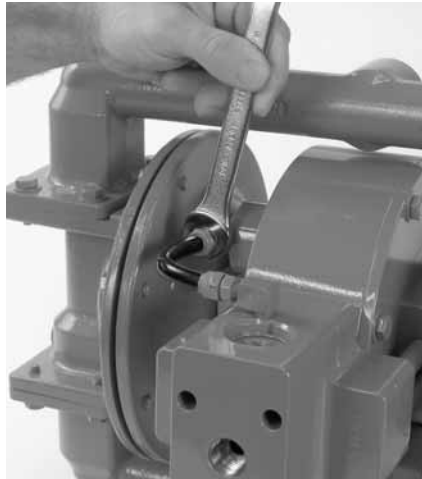

Step 2

Using a 9/16" wrench, loosen the tubing compression nuts located at each pressure relief valve.

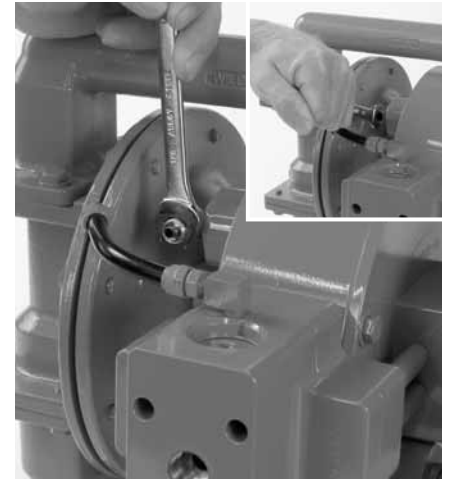

Step 3

Using a 1/2" wrench, loosen the pipe fitting and elbows to allow access to the pressure relief valve.

**Step 4**

Using an adjustable wrench, remove each pressure relief valve.

**Step 5**

Using a 5/64" hex head wrench, remove the four fasteners to disassemble the pressure relief valve.

**Step 6**

Inspect the pressure relief valve and components for nicks, gouges, chemical attack, or abrasive wear. Reassemble when complete. Replace if necessary with genuine Wilden parts. Note: Pressure relief valve is available as an assembly or a rebuild kit.

**Step 7**

Using a 3/16" hex head wrench, remove the four fasteners that connect the air valve and air valve gasket to the manifold and lift the air valve off the manifold.

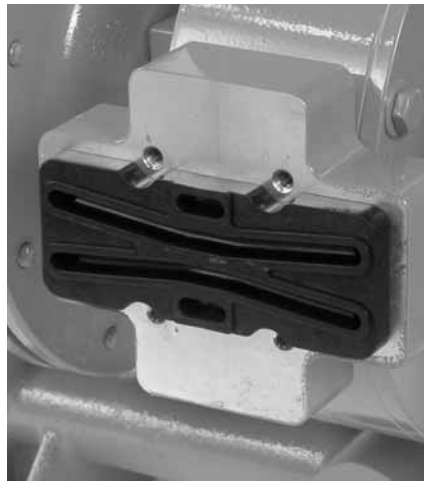
**Step 8**

Be sure to note the orientation of the air valve gasket. (The flat side mates against the manifold and the grooved side faces the air valve.)

**Step 9**

Using a pair of snap ring pliers, remove the snap ring from the bottom of the air valve body.

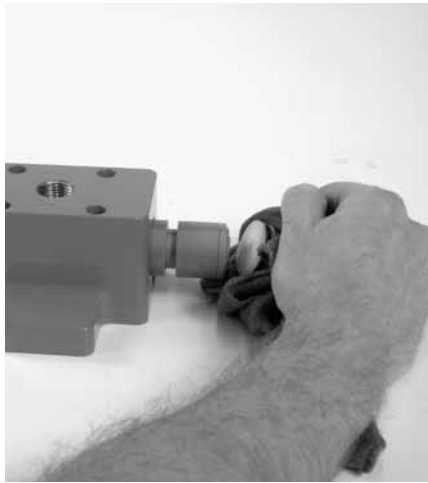

Step 10

Hints & Tips – Using an air nozzle, alternately pressurize the 1/8" NPT ports, fittings or Pressure Relief Valve tubing until the bottom end cap is forced from the air valve body, Caution: The end cap may come out with considerable force. Position a shop rag over the bottom end cap to ensure that the end cap doesn't harm the pump technician or anyone else in the immediate area.



Step 11

Inspect: air piston (including air valve rings), air valve body, and air valve end cap for nicks, gouges, chemical attack, or abrasive wear. Replace (if necessary) with genuine Wilden parts.

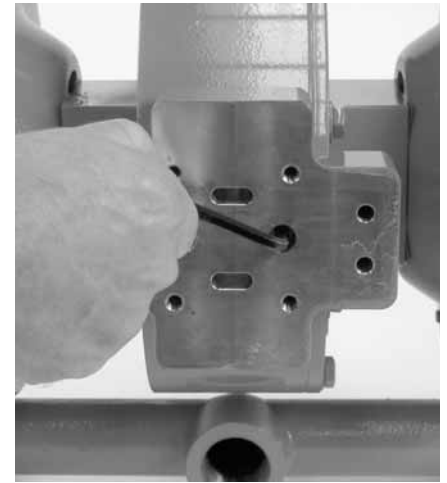

Step 12

Using a 3/16" hex wrench, remove the two air valve manifold fasteners and remove the air valve manifold.

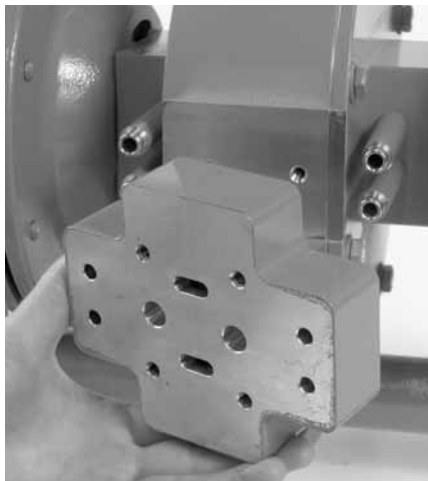

Step 13

Located behind the air valve manifold are four tubes. Remove all four tubes.



Step 14

Using a 1/2" wrench or socket, remove discharge manifold and fasteners.



Step 15

After removing discharge manifold, inspect for abrasion in the ball cage area.



Step 16

Remove valve ball, valve seat, valve seat o-ring and manifold o-ring and inspect.

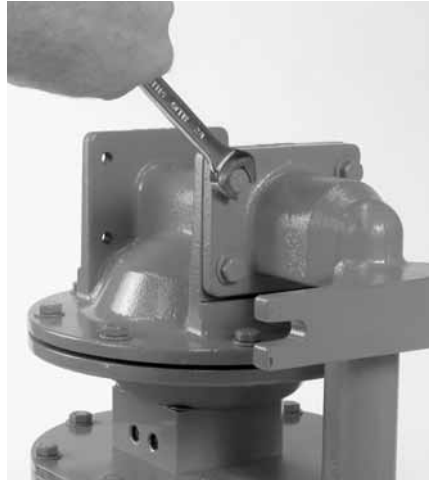

Step 17

Prior to disconnecting the inlet manifold from the liquid chambers, place the pump assembly on its side. Using a 1/2" wrench or socket, remove the inlet manifold fasteners. **Caution:** The center assembly is very heavy and could cause injury to the pump technician or anyone else in the immediate area.



Step 18

Hints & tips— Due to the liquid chamber design, the pump can be positioned on one liquid chamber as shown; you can use the liquid chamber to assist with removal of the manifolds or opposite liquid chamber.



Step 19

Remove the liquid chambers using a 1/2" wrench or socket.



Step 20

Remove one outer piston, diaphragm, and inner piston using two 1" wrenches.



Step 21

Hints & Tips – To remove the opposite diaphragm assembly, use the following steps: First, install a 5/8"-18 jam nut on the pump shaft. With a 15/16" wrench positioned on the jam nut, lock the outer piston against the jam nut using a 1" wrench on the outer piston. Holding the jam nut with the 15/16" wrench, you can now remove the opposite diaphragm assembly by turning in a counterclockwise direction.

Note: 5/8"-16 jam nut not included. Available thru McMaster-Carr# 91078A235



Step 22

Using a 1/2" socket, remove the air chamber fasteners.



Step 23

With the air chamber removed, note the orientation of the bushing and center section gasket.



Step 24

Using a 1/2" wrench, remove the fasteners that connect the power piston cylinder cover to the power cylinder body.

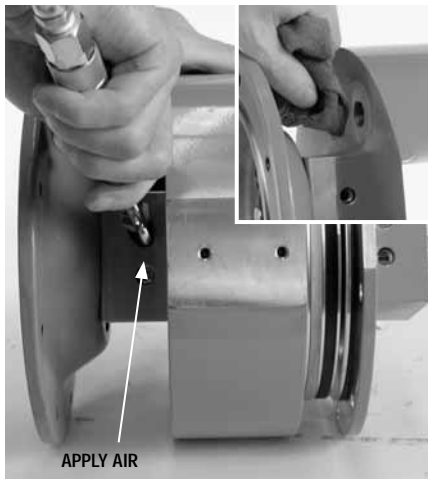

Step 25

By blocking the pressure relief port and using an air nozzle with a rubber tip, blow air through the port shown in the corresponding picture (upper left) to force the cylinder piston and center section cover from the center section. Continue to supply air to the port until the power cylinder piston is moved out of the power cylinder body. Caution: The center section cover may come out with considerable force. Position the pump in a manner to ensure that the center section cover and related parts do not harm the pump technician or anyone else in the immediate area.

WIL-11190-E-02



Step 26

Remove the center section cover and piston assembly by hand. Inspect shaft bushings, seals, and o-ring on power cylinder cover for damage.



Step 27

Using two 3/4" wrenches, break loose the two shafts from the power piston in a counter clockwise manner.

Note: Step 27 and 28 would only be required in the case of damage to the pump shaft(s)



Step 28

Inspect the shafts and cylinder piston bushings for wear and replace as necessary.

**Finding
A Spares
Nightmare?**

**PRODUCTS:
AODDP**
(Air Operated Double Diaphragm Pumps)

- Warren-Rupp®
- ARO®
- Other

PUMP PARTS
(Low Cost)

- Diaphragms
- Valve balls
- Valve seats

**KNOWLEDGE
& SERVICE**

- Competitive pricing
- Delivery
- Service
- Inventory

Sleep easier with

Spectrom is not your typical after market part supplier. We do not simply sell pump parts; we provide value added procurement solutions.

Our unique network enables us to purchase effectively, resulting in low cost solutions. We also know that low purchase price is not enough - quality, integrity and inventory are also important. Spectrom is structured to provide Pre and Post sales support, giving our customers value added application and pump knowledge.

Contact us to have a procurement solution developed for you. We don't just fit you into a generic system, we develop specific solutions that achieve results.

Spectrom will ship your order from our facility within 3 working days!

WARNING: These parts may exhibit better life than OEM parts.

1-909-512-1261 www.spectromparts.com

REASSEMBLY HINTS & TIPS

ASSEMBLY:

Upon performing applicable maintenance to the air distribution system, the pump can now be reassembled. Please refer to the disassembly instructions for photos and parts placement. To reassemble the pump, follow the disassembly instructions in reverse order. The air distribution system needs to be assembled first, then the diaphragms and finally the wetted path. Please find the applicable torque specifications on this page. The following tips will assist in the assembly process.

- Lubricate center section shaft with NLGI grade 2 white EP bearing grease or equivalent.
- Clean the inside of the center section shaft bore to ensure no damage is done to new seals.
- A small amount NLGI grade 2 white EP bearing grease can be applied to the muffler and air valve gaskets to locate gaskets during assembly.

MAXIMUM TORQUE SPECIFICATIONS - H200

Part Description	N•m	ft-lbs
Outer Piston	135.6 N•m	100 ft-lbs
Air Valve Bolts	6.8 N•m	60 in-lbs
Liquid Chamber to Air Chamber Bolts	13.6 N•m	120 in-lbs
Inlet and Discharge Manifolds to Liquid Chamber Bolts	13.6 N•m	120 in-lbs
Center Section Cover Bolts	13.6 N•m	120 in-lbs
Air Chamber to Center Section Bolts	13.6 N•m	120 in-lbs
Air Valve Manifold Bolts	6.8 N•m	60 in-lbs
*Shaft to Shaft	115.2 N•m	85 ft-lbs

*Note: Use of LocTite adhesive is recommended for this connection.

Torque all hardware in an opposing torque sequence. Liquid chamber bolts may require periodic re-tightening. If liquid chamber pre-load torque values fall below 100 in-lbs, retighten both liquid chambers to a maximum of 120 in-lbs. Liquid chamber torque loading must be even. If any of the liquid chamber bolts require retightening, it is suggested that all liquid chamber bolts be retightened to ensure even distribution.

Figure A

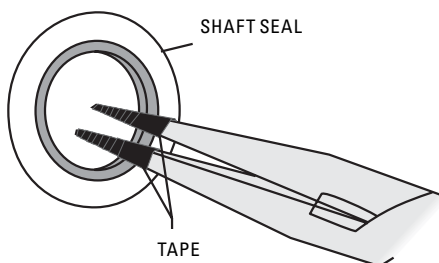

BUSHING SEAL INSTALLATION:

PRE-INSTALLATION

- Once all of the old seals have been removed, the inside of the bushing should be cleaned to ensure no debris is left that may cause premature damage to the new seals.

INSTALLATION

The following tools can be used to aid in the installation of the new seals:

- Needle Nose Pliers
- Phillips Screwdriver
- Electrical Tape

- Wrap electrical tape around each leg of the needle nose pliers (heat shrink tubing may also be used). This is done to prevent damaging the inside surface of the new seal.
- With a new seal in hand, place the two legs of the needle nose pliers inside the seal ring. (See Figure A.)
- Open the pliers as wide as the seal diameter will allow, then with two fingers pull down on the top portion of the seal to form kidney bean shape. (See Figure B.)
- Lightly clamp the pliers together to hold the seal into the kidney shape. Be sure to pull the seal into as tight of a kidney shape as possible, this will allow the seal to travel down the bushing bore easier.
- With the seal clamped in the pliers, insert the seal into the bushing bore and position the bottom of the seal into the bushing groove. Once the bottom of the seal is seated in the groove, release the clamp pressure on the pliers. This will allow the seal to partially snap back to its original shape.
- After the pliers are removed, you will notice a slight bump in the seal shape. Before the seal can be properly resized, the bump in the seal should be removed as much as possible. This can be done with either the Phillips screwdriver or your finger. With either the side of the screwdriver or your finger, apply light pressure to the peak of the bump. This pressure will cause the bump to be almost completely eliminated.
- Lubricate the edge of the shaft with NLGI grade 2 white EP bearing grease.
- Slowly insert the center shaft with a rotating motion. This will complete the resizing of the seal.
- Perform these steps for the remaining seal.

Figure B

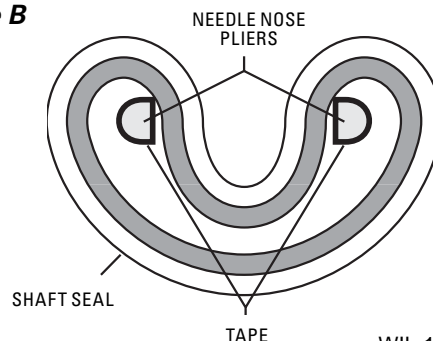

Your Solutions Wrapped Up



ELASTOMER KITS

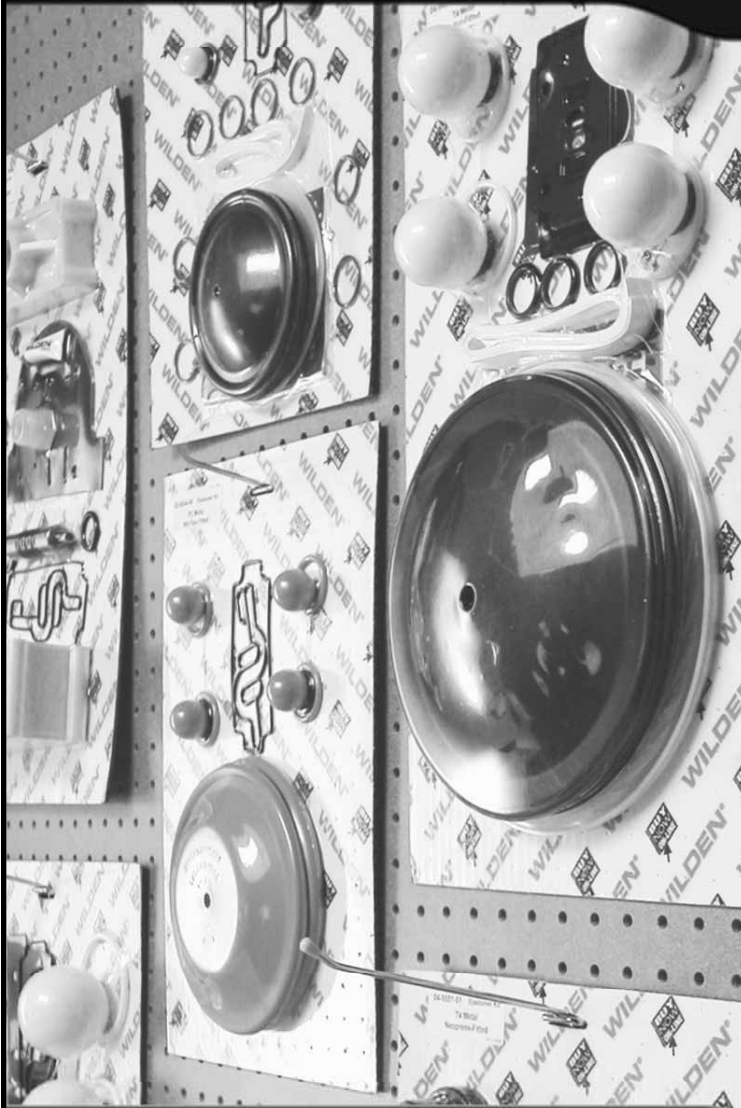

Program Details:

- Elastomer & ADS Repair Kits
- All Sizes Available
- PTFE, Rubber & TPE Elastomers
- One Part Number Simplifies Inventory
- Eliminates Order Errors
- Reduces Re-Build Time
- Rejuvenates Your Pump

NOTE: See Section 9.

WILDEN[®]
A DOVER COMPANY

22069 VAN BUREN STREET • GRAND TERRACE, CA 92313-5607
(909) 422-1730 • FAX (909) 783-3440
www.wildenpump.com

EXPLODED VIEW & PARTS LISTING

H200 METAL

Wetted Path

EXPLODED VIEW

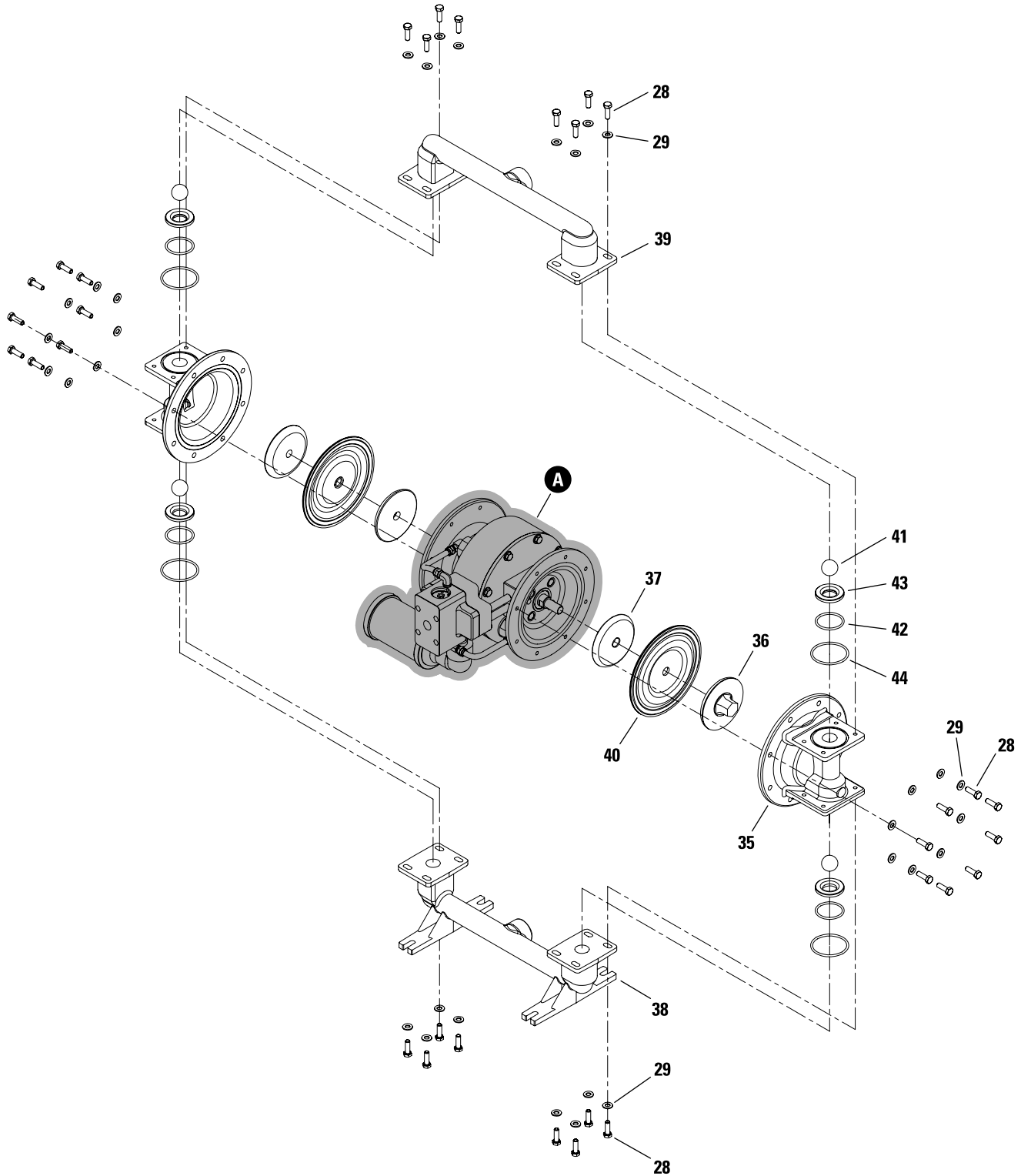

EXPLODED VIEW & PARTS LISTING

H200 METAL

Wetted Path

PARTS LISTING

Item	Part Description	Qty.	H200/ WWWAA/FWS/WF/MWF P/N	H200/ WWWAA/FWS/WF/MWF/0014 P/N
1	Air Valve Assembly¹	1	02-2003-01	02-2003-01
2	End Cap w/Guide	1	04-2300-23	04-2300-23
3	End Cap w/o Guide	1	04-2330-23	04-2330-23
4	O-Ring (.984 x .139)	2	04-2390-52	04-2390-52
5	Retaining Ring	2	04-2650-03	04-2650-03
6	Screw, SHC, Air Valve (1/14"-20 x 2")	4	04-6000-03	04-6000-03
7	Gasket, Air Valve	1	02-2603-52	02-2603-52
8	Screw, SHC, Manifold (1/4"-20 x 7/8")	2	70-6250-03	70-6250-03
9	Nipple, 3/4" NPT	1	02-7430-08	02-7430-08
10	Elbow, 90°, 3/4" NPT	1	02-3250-08	02-3250-08
11	Muffler	1	08-3510-99R	08-3510-99R
12	Bottom Air Valve Manifold	1	02-2700-01	02-2700-01
13	Relief Tube Assembly	2	02-9230-99	02-9230-99
14	Pressure Relief Valve Assembly	2	08-2740-99-60	08-2740-99-60
	Rebuild Pressure Relief Seal Kit	1	99-9346-99	99-9346-99
15	Pipe	4	02-7521-01	02-7521-01
16	O-Ring, Pipe (.364 x .070)	8	00-2286-52	00-2286-52
17	Power Piston Seal Kit²	1	02-9210-99	02-9210-99
18	O-Ring, Cover (6.487 x .103)	1	-	-
19	Guide Ring	2	-	-
20	Slipper Seal	1	-	-
21	O-Ring, Piston (5.975 x .210)	1	-	-
22	Cylinder Piston	1	02-3720-01	02-3720-01
23	Cylinder Piston Bushing	2	02-3730-03	02-3730-03
24	Shaft	2	02-3845-03	02-3845-03
25	Stud, Shaft	1	04-6150-08	04-6150-08
26	Cover, Center Section	1	02-3000-01	02-3000-01
27	Gasket, Center Section	2	02-3260-52	02-3260-52
28	Screw, HHC (5/16"-18 x 1")	48	08-6180-03-42	08-6180-03-42
29	Washer (5/16")	48	02-6731-03	02-6731-03
30	Bushing Assembly, Center Section³	2	02-3307-99	02-3307-99
31	Seal Ring	2	08-3210-55-225	08-3210-55-225
32	O-Ring, (1.109 x .139)	2	02-1200-52	02-1200-52
33	Air Chamber	2	02-3692-02	02-3692-02
34	Center Section	1	02-3154-01	02-3154-01
35	Liquid Chamber	2	02-5012-02	02-5012-02
36	Outer Piston	2	02-4565-02	02-4565-02
37	Inner Piston	2	02-3702-02	02-3702-02
38	Inlet Manifold	1	02-5092-02	02-5093-02
39	Discharge Manifold	1	02-5032-02	02-5033-02
40	Primary Diaphragm	2	02-1011-57	02-1011-57
41	Valve Ball	4	02-1085-58	02-1085-58
42	O-Ring, Seat (1.734 x .139)	4	02-1205-58	02-1205-58
43	Valve Seat	4	02-1129-08	02-1129-08
44	O-Ring, (2.539 x .139)	4	02-1372-58	02-1372-58

¹AIR VALVE ASSEMBLY INCLUDES ITEM NUMBERS 2, 3, 4, and 5.

²POWER PISTON SEAL KIT INCLUDES ITEM NUMBERS 18, 19, 20, and 21.

³CENTER SECTION BUSHING ASSEMBLY, INCLUDES QTY. 1 OF ITEM NUMBER 31 AND 32.

ALL BOLD FACE ITEMS ARE PRIMARY WEAR ITEMS.

0014 Specialty Code = BSPT

ELASTOMER KIT OPTIONS

Wil-Flex™
02-9574-57

EXPLODED VIEW & PARTS LISTING

H200 METAL

Center Section

EXPLODED VIEW

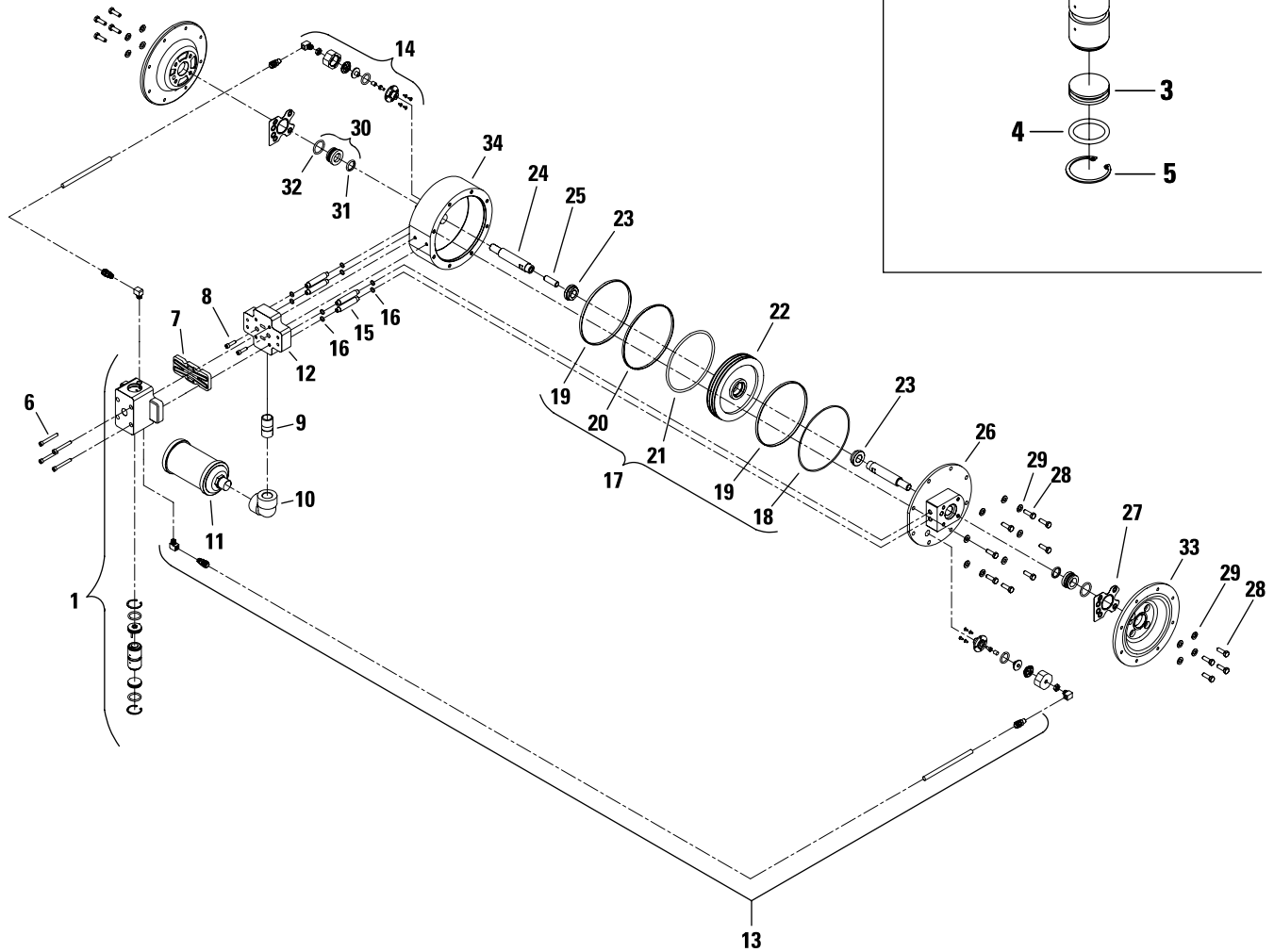

EXPLODED VIEW & PARTS LISTING

H200 METAL

Center Section

PARTS LISTING

Item	Part Description	Qty.	H200/ WWWAA/FWS/WF/MWF P/N	H200/ WWWAA/FWS/WF/MWF/0014 P/N
1	Air Valve Assembly¹	1	02-2003-01	02-2003-01
2	End Cap w/Guide	1	04-2300-23	04-2300-23
3	End Cap w/o Guide	1	04-2330-23	04-2330-23
4	O-Ring (.984 x .139)	2	04-2390-52	04-2390-52
5	Retaining Ring	2	04-2650-03	04-2650-03
6	Screw, SHC, Air Valve (1/14"-20 x 2")	4	04-6000-03	04-6000-03
7	Gasket, Air Valve	1	02-2603-52	02-2603-52
8	Screw, SHC, Manifold (1/4"-20 x 7/8")	2	70-6250-03	70-6250-03
9	Nipple, 3/4" NPT	1	02-7430-08	02-7430-08
10	Elbow, 90°, 3/4" NPT	1	02-3250-08	02-3250-08
11	Muffler	1	08-3510-99R	08-3510-99R
12	Bottom Air Valve Manifold	1	02-2700-01	02-2700-01
13	Relief Tube Assembly	2	02-9230-99	02-9230-99
14	Pressure Relief Valve Assembly	2	08-2740-99-60	08-2740-99-60
	Rebuild Pressure Relief Seal Kit	1	99-9346-99	99-9346-99
15	Pipe	4	02-7521-01	02-7521-01
16	O-Ring, Pipe (.364 x .070)	8	00-2286-52	00-2286-52
17	Power Piston Seal Kit²	1	02-9210-99	02-9210-99
18	O-Ring, Cover (6.487 x .103)	1	-	-
19	Guide Ring	2	-	-
20	Slipper Seal	1	-	-
21	O-Ring, Piston (5.975 x .210)	1	-	-
22	Cylinder Piston	1	02-3720-01	02-3720-01
23	Cylinder Piston Bushing	2	02-3730-03	02-3730-03
24	Shaft	2	02-3845-03	02-3845-03
25	Stud, Shaft	1	04-6150-08	04-6150-08
26	Cover, Center Section	1	02-3000-01	02-3000-01
27	Gasket, Center Section	2	02-3260-52	02-3260-52
28	Screw, HHC (5/16"-18 x 1")	48	08-6180-03-42	08-6180-03-42
29	Washer (5/16")	48	02-6731-03	02-6731-03
30	Bushing Assembly, Center Section³	2	02-3307-99	02-3307-99
31	Seal Ring	2	08-3210-55-225	08-3210-55-225
32	O-Ring, (1.109 x .139)	2	02-1200-52	02-1200-52
33	Air Chamber	2	02-3692-02	02-3692-02
34	Center Section	1	02-3154-01	02-3154-01
35	Liquid Chamber	2	02-5012-02	02-5012-02
36	Outer Piston	2	02-4565-02	02-4565-02
37	Inner Piston	2	02-3702-02	02-3702-02
38	Inlet Manifold	1	02-5092-02	02-5093-02
39	Discharge Manifold	1	02-5032-02	02-5033-02
40	Primary Diaphragm	2	02-1011-57	02-1011-57
41	Valve Ball	4	02-1085-58	02-1085-58
42	O-Ring, Seat (1.734 x .139)	4	02-1205-58	02-1205-58
43	Valve Seat	4	02-1129-08	02-1129-08
44	O-Ring, (2.539 x .139)	4	02-1372-58	02-1372-58

¹AIR VALVE ASSEMBLY INCLUDES ITEM NUMBERS 2, 3, 4, and 5.

²POWER PISTON SEAL KIT INCLUDES ITEM NUMBERS 18, 19, 20, and 21.

³CENTER SECTION BUSHING ASSEMBLY, INCLUDES QTY. 1 OF ITEM NUMBER 31 AND 32.

ALL BOLD FACE ITEMS ARE PRIMARY WEAR ITEMS.

0014 Specialty Code = BSPT

ELASTOMER KIT OPTIONS

Wil-Flex™
02-9574-57

Pump Solids

Maximize Your Yield

Is your process limping along with a pump that wasn't designed to transfer sanitary solids? Are your inspection, cleaning, and maintenance costs too high? Are you looking for a pump that is actually designed for your application?

Wilden has your answer. The Saniflo™ VC pump can transfer your product without damage from bruising or shearing. The pump is specifically designed to meet your performance needs while minimizing cleaning and inspection time. Contact us for a unique perspective and proven results. The Saniflo™ VC will handle any food product that you can dish out.

- **3 sizes available**
- **Solids passage to 152 mm (6")**
- **Stainless steel construction**
- **Only 2 moving parts**
- **Low liquid content requirement**
- **Complies with USDA requirements**
- **Variable flow**
- **CE marked**
- **Low voltage directive by TÜV**
- **PED & machinery directive**



WILDEN
A DOVER COMPANY

22069 VAN BUREN STREET • GRAND TERRACE, CA 92313-5607
(909) 422-1730 • FAX (909) 783-3440
www.wildenpump.com

SANIFLO™ VC PUMP

WARRANTY

Each and every product manufactured by Wilden Pump and Engineering, LLC is built to meet the highest standards of quality. Every pump is functionally tested to insure integrity of operation.

Wilden Pump and Engineering, LLC warrants that pumps, accessories and parts manufactured or supplied by it to be free from defects in material and workmanship for a period of five (5) years from date of installation or six (6) years from date of manufacture, whichever comes first. Failure due to normal wear, misapplication, or abuse is, of course, excluded from this warranty.

Since the use of Wilden pumps and parts is beyond our control, we cannot guarantee the suitability of any pump or part for a particular application and Wilden Pump and Engineering, LLC shall not be liable for any consequential damage or expense arising from the use or misuse of its products on any application. Responsibility is limited solely to replacement or repair of defective Wilden pumps and parts.

All decisions as to the cause of failure are the sole determination of Wilden Pump and Engineering, LLC.

Prior approval must be obtained from Wilden for return of any items for warranty consideration and must be accompanied by the appropriate MSDS for the product(s) involved. A Return Goods Tag, obtained from an authorized Wilden distributor, must be included with the items which must be shipped freight prepaid.

The foregoing warranty is exclusive and in lieu of all other warranties expressed or implied (whether written or oral) including all implied warranties of merchantability and fitness for any particular purpose. No distributor or other person is authorized to assume any liability or obligation for Wilden Pump and Engineering, LLC other than expressly provided herein.

PLEASE PRINT OR TYPE AND FAX TO WILDEN

PUMP INFORMATION			
Item # _____		Serial # _____	
Company Where Purchased _____			
YOUR INFORMATION			
Company Name _____			
Industry _____			
Name _____		Title _____	
Street Address _____			
City _____	State _____	Postal Code _____	Country _____
Telephone _____	Fax _____	E-mail _____	Web Address _____
Number of pumps in facility? _____		Number of Wilden pumps? _____	
Types of pumps in facility (check all that apply): <input type="checkbox"/> Diaphragm <input type="checkbox"/> Centrifugal <input type="checkbox"/> Gear <input type="checkbox"/> Submersible <input type="checkbox"/> Lobe			
<input type="checkbox"/> Other _____			
Media being pumped? _____			
How did you hear of Wilden Pump? <input type="checkbox"/> Trade Journal <input type="checkbox"/> Trade Show <input type="checkbox"/> Internet/E-mail <input type="checkbox"/> Distributor			
<input type="checkbox"/> Other _____			

ONCE COMPLETE, FAX TO (909) 783-3440

NOTE: WARRANTY VOID IF PAGE IS NOT FAXED TO WILDEN
WILDEN PUMP & ENGINEERING, LLC