

FCSII

Engineering Operation & Maintenance



WILDEN®

A **DOVER** COMPANY

FCSII

FLOW CONTROL SYSTEM

Pump Controller

PRINTED IN THE USA

TABLE OF CONTENTS

	PAGE #
CAUTIONS/WARNINGS	INSIDE FRONT COVER
FLOW CONTROL SYSTEM™ II (FCSII)	1A
WILDEN ACCU-FLO™ PUMP TECHNOLOGY	1A
OPTIMAL ACCURACY AND REPEATABILITY	2A
DIMENSIONAL DRAWING/SPECIFICATIONS	3A
KEYPAD FUNCTIONS	4A
• COUNTER/TOTALIZER	4A
FCSII TERMINAL DESCRIPTIONS	5A
INSTALLATION	6A
• GENERAL	6A
• AUTO-ON FEATURE	6A
• LEAK DETECT	6A
• CONFIGURATION SECURITY	6A
• AUTO-FILL	6A
SYSTEM CONFIGURATION/PROGRAMMING	8A
• BATCH MODE PROGRAMMING	8A
• CONSTANT RUN MODE PROGRAMMING	9A
• 4 - 20 mA MODE PROGRAMMING	9A
EXAMPLE	10A
TROUBLESHOOTING	11A
FCSII HOOKUP SCHEMATIC	12A
• STANDARD INSTALLATION	12A
• AUTO-FILL MODE INSTALLATION	12A
• EXTERNAL INPUT SIGNAL EXAMPLES	13A
• 4 - 20 mA EXTERNAL INPUT	13A

CAUTIONS/WARNINGS – READ FIRST!

The Flow Control System II is designed to be used with Wilden's Nema 4 or Nema 7 12V DC solenoid-operated pumps only. Do not power other coil options available from Wilden Pump & Engineering Company with the FCSII.

- Incorrect electrical connection may cause damage
- Unit is designed to power a 12V DC solenoid coil only.
- Vibration and shock to this equipment should be avoided.
- Disconnect all power sources prior to opening control module.
- Don't mount in splash area.
- The unit can have high voltages present inside the enclosure. **Never** power the FCSII with the cover off.
- The input to the unit requires a dry contact (SPST normally open). **Never** apply a voltage to the inputs.
- Use caution when programming FCSII to ensure that automatic, pre-programmed pump operation cannot cause injury

or damage.

- The unit's output is fused, but an external fuse should be used to safeguard the equipment.
- Totalizer will roll-over to zero at a count of 10,000,000 cycles.
- When operating auto-fill function, a redundant float switch above the top one (N.O.) may be connected to "Leak Det." terminals for added protection.

This equipment generates and uses radio frequency energy and may cause interference to radio and television reception. If this equipment does cause interference to radio or television reception, which can be determined by turning the equipment off and on, the user is encouraged to try to correct the interference by one or more of the following measures:

- Reorient the receiving antenna
- Relocate the computer with respect to the receiver
- Plug the computer into a different outlet so that the computer and receiver are on different branch circuits

If necessary, the user should consult the dealer or an experienced radio/television technician for additional suggestions. The user may find the following booklet prepared by the Federal Communications Commission helpful: "How to Identify and Resolve Radio-TV Interference Problems." This booklet is available from the U.S. Government Printing Office, Washington, DC 20402, Stock No. 004-000-00345-4.



WARNING: Unit may cause electric shock if used or installed improperly.

THE FLOW CONTROL SYSTEM™ II (FCSII)

The Flow Control System™ II, a state of the art microprocessor controlled batching computer, further broadens the scope of applications suitable for the Wilden pump to include batching and metering. The principles of operation are quite simple. A Wilden Accu-flo™ pump discharges a repeatable amount of process fluid on every stroke of the diaphragm. The FCSII counts the strokes and controls the pump so that specific, repeatable quantities can be batched.

The FCSII has a user-friendly interface. The operating software within the FCSII has been designed to be configured for use in a variety of applications. The system allows the user to customize data based on specific application calculations. Once the system is programmed, the data is held in memory even when the unit is off or disconnected. The back-lit LCD display is easy to read, even in poor lighting conditions. It displays text and numbers, which enables the user to interface with the FCSII in English, instead of referring to a thick technical manual.

The FCSII allows three separate batch quantities to be programmed. In addition, the FCSII can accept input from a host of external sensors or switches supplied by the user to customize the application. The FCSII also allows the user to program a batch to repeat itself at preset time intervals, for a specific number of cycles. In addition, an external 4–20 mA input signal can control the flow by regulating the pump speed.

This unit incorporates the latest advancements in computer technology to accomplish its task. It features *optically isolated, solid state solenoid control* for safe, consistent, trouble-free operation. The water resistant, heavy-duty enclosure and a polyester membrane switch keypad allows the unit to withstand most harsh environments.

WILDEN ACCU-FLO™ PUMP TECHNOLOGY

Wilden Accu-Flo™ pump technology uses compressed air as a driving force to displace process fluid while electric signals control pump speed. Inherent characteristics allow solenoid-operated pumps to excel in difficult pumping applications where other pump types fail.

The Wilden Accu-Flo™ solenoid valve uses electrical impulses to stroke the pump. This valve is a two-position, four-way solenoid valve that has a single operator and spring return. When electric

power is applied, the solenoid shifts to allow an air chamber to be pressurized with air. When the electric power is removed, the spring return mechanism shifts the solenoid valve to a position where the pressurized air chamber is exhausted while the opposite air chamber is pressurized. By alternately applying and removing electrical power, the pump reciprocates much like a standard Wilden pump. The faster the electrical impulses are provided to the pump, the faster the pump operates.

OPTIMAL ACCURACY AND REPEATABILITY

Wilden air-operated, double-diaphragm pumps discharge a repeatable volume of process fluid on each discharge stroke. For this reason, metering and batching are easily accomplished with the FCSII. The FCSII simply counts the strokes and controls the pump so that specific, repeatable quantities can be batched. The process can only be batched in multiples of the displacement figure. In addition, the unit always stops the solenoid pump on an even stroke count to insure that the pump is normally unpowered. The FCSII can generate batch quantities with up to 99% repeatability if the application is installed as noted below and programming is executed correctly.

Consistent displacement per stroke of process fluid is the key to insure that repeatable batch quantities are achieved. Displacement per stroke is dependent on many factors. If any of these factors change, then the displacement per stroke and batch quantity may be altered. This would lead to a decrease in accuracy.

THERE ARE A FEW MEASURES WHICH OPTIMIZE ACCURACY BY ENSURING DISPLACEMENT CONSISTENCY.

- Inlet and discharge lines to be primed at all times. This is accomplished by utilizing a foot valve on suction lift conditions and a check valve on the discharge line.
- Consistent pump fluid inlet and discharge pressures.
- Consistent air inlet pressure to the pump.
- Consistent viscosity of the process fluid.
- Consistent specific gravity of the process fluid.

WILDEN ACCU-FLO™ PUMP DISPLACEMENT PER STROKE

These figures are approximate. Displacement per stroke is based on many factors, including inlet/discharge pressures, viscosity, suction lift, temperatures, etc. The data was measured at 70 psi air inlet pressure and 30 psi head pressure. The data is provided in gallons/stroke.

	METAL/ RUBBER	METAL / TEFLON®	PLASTIC/ RUBBER	PLASTIC/ TEFLON®
A.025	NA*	NA*	.005	.005
A1	.030	.025	.030	.028
A2	.102	.058	.092	.054
A4	.260	.110	NA*	NA*
A8	.550	.280	NA*	NA*
A15	1.000	.62	NA**	NA**
A20	NA**	NA**	NA**	NA**

*Model is available, data unavailable

**Model is unavailable

DIMENSIONAL DRAWING WILDEN FLOW CONTROL SYSTEM™ II

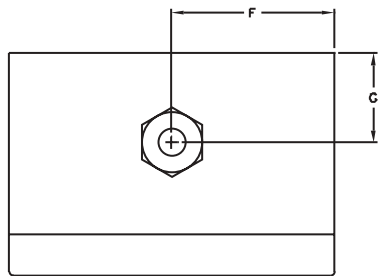
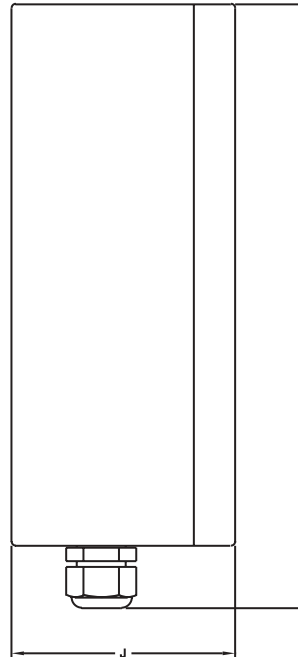
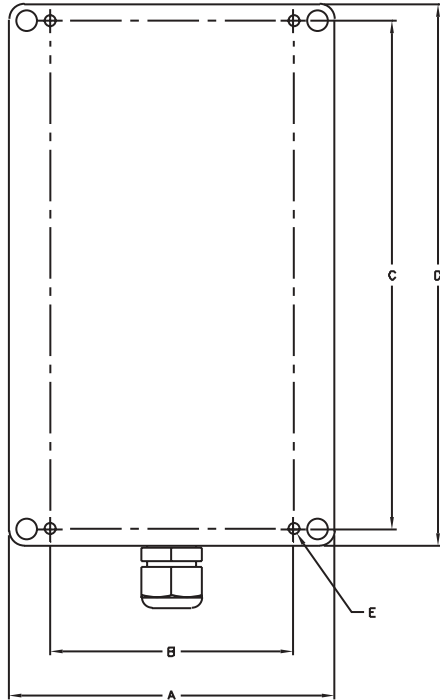

DIMENSIONS — FSCII		
ITEM	METRIC (mm)	STANDARD (inch)
A	118.9	4.68
B	89.4	3.52
C	187.7	7.39
D	198.1	7.80
E	Ø 4.3	Ø .17
F	59.2	2.33
G	34.3	1.35
H	222.3	8.75
J	76.5	3.01

SPECIFICATIONS

Enclosure: Nema 4X, ABS case with clear polycarbonate cover and stainless steel screws.

Cable Grip: Polyamide (nylon) with Buna seal, "liquid tight," 10.15 mm (0.4") cable capacity.

Keypad: Polyester membrane type. Splash proof with tactile interface.

Power Requirements: 110-120V AC 50/60 Hz., 220-230V AC 50/60 Hz., 15 watts.

Pump Output Voltage and Amps: 12V DC .750 amps. Recommended Solenoid coil DC resistance nominal 16 Ohms.

Contact Requirements for External Input Activation: Dry contact rated at 1 mA or greater.

Wil-Gard Input: Dry contact rated at 1 mA or greater.

External Output: Relay contacts. The ratings are 100v DC at 0.5 amps, maximum.

Power Cord: U.S.-style non-grounding cord, 1.83m (6') UL/CSA listed.

Solenoid Cord: 18 ga. stranded zip cord, 2.44m (8').

Operating Temperature: 0°C (32°F) to 50°C (122°F).

Storage Temperature: -10°C (14°F) to 60°C (140°F).

Fuse: Internally resettable (non-replaceable). Hold = .65 Amps, Trip = 1.3 Amps, UL, CSA & TUV recognized.

RECOMMENDED WIRE GAUGE:

Power Input Wire: 18 AWG minimum/max distance 100'.

Wire to Solenoid Pump: 18 AWG minimum/max distance 150'.

Wil-Gard Input Wire: 24 AWG minimum/max distance 1000'.

KEYPAD FUNCTIONS

MODES:

1. **BATCH:** This mode is used to initiate and set the batch information. Continually pressing the button allows you to select between three batches. This function can also be initiated by an external signal.
2. **CONSTANT RUN:** This mode is used to run the pump continually. This function can also be initiated by an external signal.
3. **4 – 20 mA:** This mode allows the user to control the pump speed using a standard 4 – 20 mA output available from many electrical devices.

PROGRAM:

4. **SET:** This button is used to select and change parameters. For example: pump speed, strokes per second and number of batches.
5. **UP¹:** This button is used to increase the displayed setting.
6. **DOWN¹:** This button is used to decrease the displayed setting.

¹When not adjusting programming, these buttons can be used to scroll through display screens for viewing purposes while pump is stopped or running.

ACTION:

7. **RUN:** This button will activate the pump in the desired mode until either stopped, paused or the batch has completed its cycle.
8. **PAUSE:** This button will pause pump operation until stopped or "pause" is pressed again. When in batch mode, the program will continue from the paused position.
9. **STOP:** This button will stop pump operation.
10. **ON/OFF:** Used to turn the unit on and off. All programmed data will be saved when the unit is turned off or unplugged.

COUNTER/TOTALIZER:

In constant run mode the "Up" and "Down" button is used to toggle between the Totalizer and the Counter.

COUNTER: This is an automatic internal counter that operates when the unit is in the "Run" mode. The counter automatically counts the cycles of the pump when operating in a continuous mode. The counter resets to zero when the pump is restarted or the mode is changed. When the unit is paused the counter will also pause, and will resume when the "Run" button is pressed. The counter rolls over at 10,000,000 (if permitted to continue to run).

TOTALIZER: The totalizer automatically counts and totals the number of times the pump has cycled. This number is continuous with all modes of operation. The totalizer does not reset when the mode of operation changes or when the unit is powered off. When powered off the number is stored in memory and restarts when the unit is powered back on. The totalizer will roll over at the count of 10,000,000. The totalizer may be reset by turning the unit on with the pause button depressed.

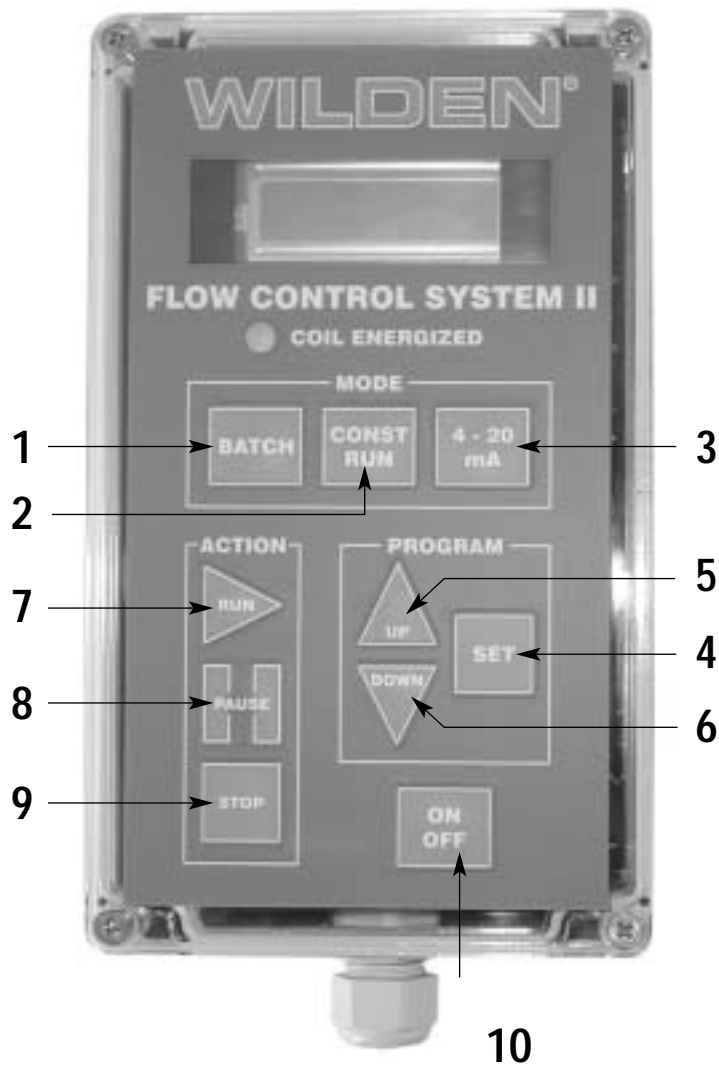

TOTALIZER USED FOR PREVENTATIVE MAINTENANCE

Preventative maintenance is an effective way to reduce maintenance cost and down time while increasing productivity. Diaphragm pumps have the following major wear parts: elastomers (diaphragms, valve balls, and O-rings) and the air distribution system (air valve and center section O-rings). The life of these components dramatically differ depending on application specifics which include: air pressure, pump speed, quality of air supply, liquid temperature, abrasiveness, etc. It is very difficult to project the life of these components without empirical data, therefore it is advisable to monitor cycle life to the first failure. Take this figure and then factor in a safety margin. This new figure is your preventative indicator.

The FCSII totalizes the number of cycles the pump has completed. When the totalizer indicates your preventative count, it is time for parts replacement. The total number of cycles is displayed on the LCD display and will roll-over at a count of 10,000,000 (software limitation). Please contact your local distributor for more information regarding preventative scheduling.

FCSII TERMINAL DESCRIPTIONS

1. **Input Common:** This terminal provides the ground to which all external inputs must be connected for activation.
2. **Solenoid:** These two terminals are used to connect to the Accu-Flo™ pump coil. Wires can be placed in either terminal regardless of polarity.
3. **External Output:** These terminals are connected to a relay which closes when the FCSII is in the run mode and opens when the FCSII is stopped.
4. **External Pause:** This input is used to pause pump operation. To be used in connection with an input common terminal (1 or 14).
5. **Batch 3:** This input is used to initiate Batch 3 remotely. To be used in conjunction with an input common terminal (1 or 14).
6. **Batch 2:** This input is used to initiate Batch 2 remotely. To be used in conjunction with an input common terminal (1 or 14).
7. **Batch 1:** This input is used to initiate Batch 1 remotely. To be used in conjunction with an input common terminal (1 or 14).
8. **4 – 20 -:** This terminal is used for the negative 4 – 20 mA external input, used to control pump speed remotely.
9. **4 – 20 +:** This terminal is used for the positive 4 – 20 mA external input, used to control pump speed remotely.
10. **Leak Detect:** This input is used to stop pump operation remotely. To be used in conjunction with an input common terminal (1 or 14).
11. **Auto-Fill Top:** This input is used for the “Top” float switch (i.e. open when not buoyed by liquid). To be used in conjunction with an input common terminal (1 or 14).
12. **Auto-fill Bottom:** This input is used for the “Bottom” float switch (i.e. closed when not buoyed by liquid). To be used in conjunction with an input common terminal (1 or 14).
13. **Ext. Contr:** This input is used to signal the FCSII to run the pump constantly. To be used in conjunction with an input common terminal (1 or 14).
14. **Input Common:** This terminal provides the ground to which all external inputs must be connected for activation. This is an additional ground (identical to #1) to be used when multiple inputs are used.
- X. Power terminal used for both 115v and 230v connections.
- Y. Power terminal used in conjunction with “X” for 115v.
- Z. Power terminal used in conjunction with “X” for 230v.

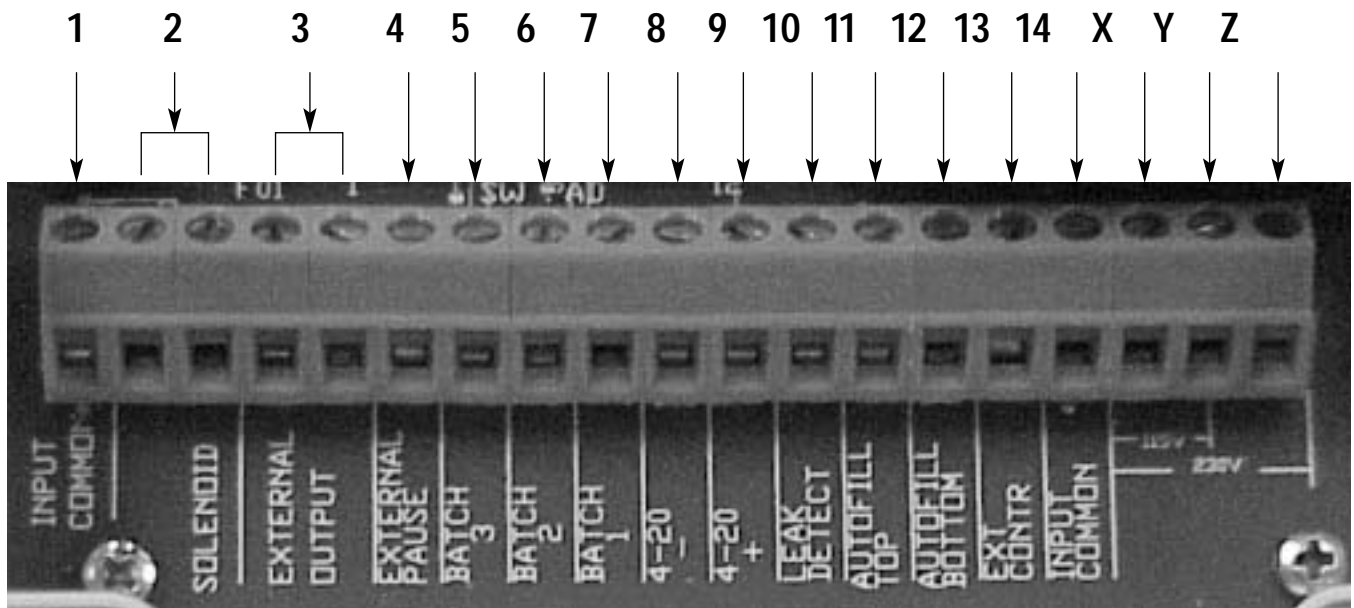

Figure 1

INSTALLATION

INSTALLATION — General

The FCSII can be powered by two voltage options, by simply connecting the power cord to the appropriate terminal connector.

Voltage and current choices:

- 110–120V AC 50/60 Hz (Figure 1, pg. 5A, X and Y).
- 220–230V AC 50/60 Hz (Figure 1, pg. 5A, X and Z).

The module is splash resistant, but should be mounted in a dry, safe, accessible location. To mount module to a wall or other structure, remove lid, secure module with screws through holes provided in back of module, verify the integrity of all connections, tighten cable grip, and attach lid.

The FCSII must be mounted in a “safe area.” The Nema 7 Wilden Accu-Flo™ pump can be located in Class I, Division I, Categories C and D areas. Verify the Nema 7 coil approval prior to usage.

All electrical specifications are listed on page 3A. Failure to comply with these specifications will result in improper performance or possible damage to the controller and/or the Accu-Flo™ pump. The unit should be installed by a qualified electrician.

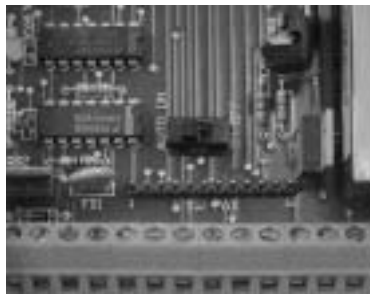

Figure 2

INSTALLATION — “Auto On” Feature

The FCSII has an “Auto On” feature. When the “Auto On” feature is in the off position (On/Off), the unit will be switched on and off via the “Power On/Off” button (i.e. the ON/OFF button must be depressed for the unit to be powered). If the “Auto On” feature is in the ON position (Auto On), the unit will be in ON mode whenever power is applied. This feature works in conjunction with external inputs to automate your process. To activate the “Auto On” feature, simply position the switch to the left as indicated in Figure 2.

INSTALLATION — Leak Detect

The FCSII has a terminal for an external leak detect stop interface. The external leak detect stop can be wired to any device that can provide

a dry contact closure (relay or switch). This will remotely switch the FCSII to the stop mode. (See Figure 1, pg. 5A, Number 10.)

INSTALLATION - Configuration Security

The FCSII has a safeguard option that disables programming changes or modifications.

Simply remove the red jumper (see Figure 3, Jumper P/D) and rotate it 90° and place it on one post only. This disables FCSII programming changes.

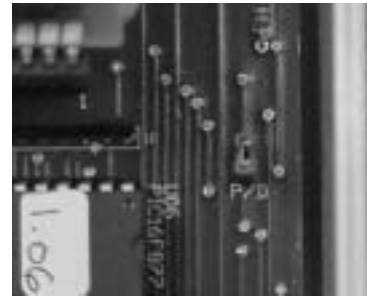

Figure 3

Note: This does not affect the operation of the unit. It allows only authorized individuals to change the programming.

INSTALLATION — Auto Fill

The FCSII can be used to fill a tank and maintain the tank level between two float switches. This is accomplished via the Auto Fill feature.

The pump starts pumping when the liquid level drops to the lower switch level. The pump starts and continues pumping until the upper limit switch is reached.

This feature can also be used to drain a tank or sump. The pump will start when the upper limit is triggered and stop when the lower limit is triggered, to eliminate conditions where the pump runs dry.



Figure 4

To activate this feature, remove the Auto Fill jumper (see Figure 4) and rotate 90° and place the jumper on one post only. When Auto Fill mode is enabled, mode buttons are disabled. Auto Fill pump speed is determined by the constant run speed setting.

INSTALLATION — Auto Fill

To use the Auto Fill feature of the FCSII, the system requires the input of two float switches. An optional redundant shut-off can be employed to safeguard the system from a costly overflow situation. To activate the feature, simply remove the Auto Fill jumper (see Figure 4).

1. The "Bottom" switch which is normally closed (i.e., closed when not buoyed by liquid)
2. The "Top" switch which is normally open (i.e., open when not buoyed by liquid)
3. The optional "Leak Det" switch which is normally open (i.e., open when not buoyed by liquid)

The Bottom switch is placed where you wish the liquid level to start the pump thus refilling the container.

The Top switch is placed where you wish the liquid level to stop the pump when the maximum level is reached.

The Leak Det switch is located above the Top switch and is a redundant shut off in the event that the Top float switch fails.

The bottom and top switches share one common terminal marked "Input Common". The other wire from the top switch is connected to "Top"

terminal (Figure 1, pg. 5A, number 11).

The other bottom lead is connected to the "Bottom" terminal (Figure 1, pg. 5A, number 12).

The wires from the redundant switch are connected to the "Leak Detect" terminal and reduce the possibility of an overflow resulting from a failed float switch.

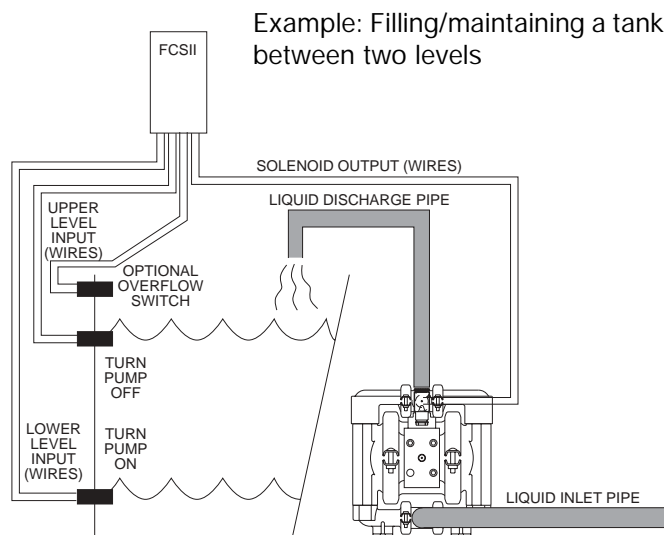

The Auto Fill function can also be used to empty a tank/sump which is filled by another source. **Important: The position of the float switch wiring must be reversed.**

1. The "Bottom" switch which is normally closed (i.e. closed when not buoyed by liquid) remains in the bottom position, but is wired to the "Top" terminal (Figure 1, pg. 5A, number 11).
2. The "Top" switch which is normally open (i.e., open when not buoyed by liquid) remains in the top position, but is wired to the the "Bottom" terminal (Figure 1, pg. 5A, Number 12).

The "Top" switch is placed where you wish the liquid level to start the pump preventing container overflow.

The "Bottom" switch is placed where you wish the liquid level to stop the pump preventing the pump from running dry.

The bottom and top switches share one common terminal marked "Input Common". The other wire from the top switch is connected to Auto Fill "Bottom" terminal.

The other wire from the bottom switch is connected to the "Top" terminal.

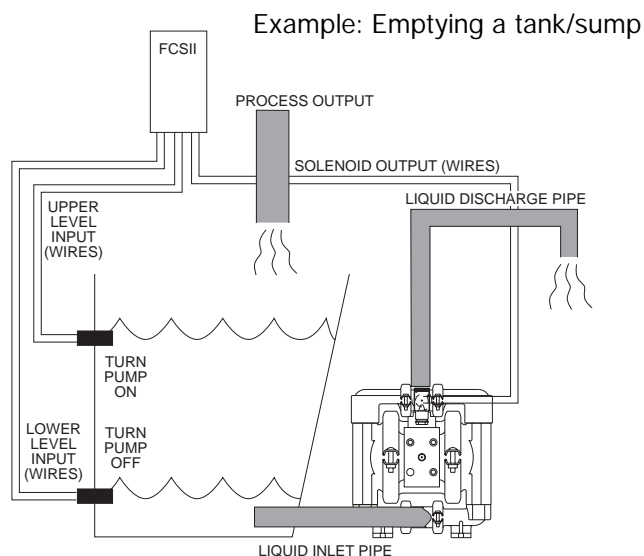

SYSTEM CONFIGURATION/ PROGRAMMING

Batch Mode Programming

Select the desired batch by continually pressing the batch button until desired batch option appears, Batch 1, 2 or 3. These modes can also be initiated by an external signal.

Program Buttons while in batch mode:

While in batch mode the program buttons are used to set the operational parameters of each Batch. While in Batch mode press the "Set" button in the program area of the keypad. This allows the parameters to be changed.

Programming Cycles:

Press the "Up" and "Down" buttons to select the desired number of pump cycles you want the batch to perform. When complete press the "Set" button to implement your changes.

```
BATCH 1  STOP
#CYCLES = 30
```

Programming the Speed:

Press the "Up" and "Down" buttons to select the desired pump speed for the current batch. When complete, press the "Set" button to implement your changes.

```
BATCH 1  STOP
SPEED = 0.05
```

Programming the number of batches:

Press the "Up" and "Down" buttons to select the desired number of batches to repeat. When complete press the "Set" button. Note: If set to zero, the batch will repeat indefinitely.

```
BATCH 1  STOP
#BATCHES = 1
```

Programming the repeat timer:

Press the "Up" and "Down" buttons to select the desired time interval between batches (in seconds). When complete press the "Set" button. This setting is only used when batches repeat multiple times.

```
BATCH 1  STOP
TIMER 00:00:00
```

The pump is now ready to batch:

To activate the batch, press the run button.

Constant Run Mode Programming

This mode is used to run the pump indefinitely until stopped or paused. This mode can also be initiated by an external signal. Press the "Constant Run" button in the mode section.

Constant Run Mode Programming:

To alter the speed in constant run mode, press the "Set" button in the Program area and use the "Up" and "Down" buttons to increase or decrease the speed. The lower the number, the faster the speed. When the desired speed is selected press the "Set" button to confirm your entry.

The pump is now ready for continuous operation:

To activate, press the run button.

CONT RUN	STOP
SPEED =	0.05

4-20 mA Mode Programming

Press the "4 - 20mA" button in the Mode area. Press the "Set" button in the Program area of the keypad. Select the desired mA where the pump should stop. Press "Set" to confirm. Select the desired pump speed at the lower mA setting previously selected. Press "Set" to confirm. Select the desired pump speed at 20 mA and press "Set" to confirm. The unit will interpolate intermediate pump speeds for intermediate mA values.

The pump is now ready for 4-20 mA operation:

To activate, press the run button.

4-20MA	STOP
04MA =	0.05

4-20MA	STOP
20MA =	10.00

EXAMPLE

Company "Chemical Experts" has an application where an employee fills drums with their new "SuperChem" product for shipment to their customers.

They would like to automate this process to free their employee for other tasks and to avoid overfilling the drum (which wastes their expensive product) or underfilling the drum (which makes their customers unhappy).

Wilden was the supplier of choice for this application due to their expertise with chemical applications and a state-of-the-art product line. The local Wilden distributor was contacted and quickly provided an FCSII (Flow Control System™ II) and an Accu-Flo™ A2 pump.

The FCSII was pre-wired for 120VAC, so all the customer had to do was plug it into the wall – and attach the pre-connected pump wires to the NEMA 4X connector supplied with the Accu-Flo™ pump. The suction and discharge piping was attached to the pump, 100 psi air was supplied to the pump, and they were ready to go!

The first drum was placed into position, and constant run mode was used to determine the number of cycles needed to fill the drum. They were careful to use the same pump speed in both constant run and batch modes to ensure accuracy.

- The "constant run" mode button was pressed.
- The "set" button was pressed to initiate programming.
- The "up" and "down" buttons were used to set the desired cycle rate of 0.2 seconds per stroke.
- The "set" button was depressed again to implement their desired speed.
- Next, the "run" button was pressed to initiate pump operation.
- While the pump was filling the drum, they used the "up" and "down" buttons to scroll to the "counter" display.
- They pressed "stop" when the liquid in the drum reached the desired level and observed that 4241 pump cycles were needed to fill the drum.

Now they were ready to program the unit for unattended operation.

- The "batch" mode button was pressed, and

batch 1 was selected.

- The "set" button was pressed to initiate programming.
- The "up" and "down" buttons were used to set the desired number of cycles – 4241 cycles.
- The "set" button was depressed again to implement their desired batch.
- The "up" and "down" buttons were then used to set the desired cycle rate of 0.2 seconds per stroke.
- The "set" button was depressed again to implement their desired speed.
- The "up" and "down" buttons were then used to set the desired number of batches – 1 batch. They were careful to ensure that only one batch was selected. It would make quite a mess if the unit started a second batch with no drum in place!
- The "set" button was depressed again to implement their desired batch quantity.
- The "up" and "down" buttons were then used to set the desired time between batches – 00:01:00. This number really did not do anything, because they were not repeating the batch automatically.
- The "set" button was depressed again to implement their desired time interval.

They were now ready to batch automatically. They put a second drum in place and pressed "run". The pump started, filled the drum, and then stopped. The second drum was filled to the identical level of the first drum! You could walk away while the pump was filling the drum! They had to pump slowly because they had a shear sensitive material – and it wasted a lot of their employee's time just standing around watching the drum fill. This was an excellent opportunity for savings.

After one year, the accounting department estimated that they saved \$10,000 in employee labor by automating the process. In addition, it was estimated that \$3,000 was saved in wasted product that went into overfilled drums. Accidental spills in production due to overfilling were eliminated and customer complaints of underfilled drums were eliminated. As usual, Wilden comes through again!

TROUBLESHOOTING

Condition: The LCD screen is not operable.

- Verify the voltage and current to FCSII.
- Verify that the wires are properly connected to the correct terminal connector.
- Turn the unit off for 10 seconds, then turn back on (cold boot).

Condition: The LCD screen is operable, but the pump is not running.

- Verify that the LCD indicates that the unit is in the RUN mode and that the green LED is lighting at the appropriate interval.
- Shut the unit off for 10 minutes to permit the internal fuse to reset.
- Verify that there is a solid electrical connection between the FCSII's output and the solenoid and that the solenoid is functional.
- Verify that sufficient air pressure is supplied to the pump (must be more than liquid discharge pressure).
- Verify that the minimum air pressure requirement of 45 psi is met.
- Listen for "clicking" noise at solenoid valve when coil is energized or de-energized regardless if air pressure is applied to the pump. If no noise is heard, wiring may be loose or incorrectly installed.
- Stroke interval may be set too high (i.e., the pump is running, but at a very slow rate).
- Verify that the "emergency stop" terminal connector is not grounded.

Condition: The pump won't run in Ready mode when "Constant Run" button is pressed.

- Is the solenoid energizing? (A rhythmical clicking should be heard when the constant run button is pressed. This is the solenoid shifting back and forth.)
- Yes: If the solenoid is shifting back and forth, then there may be insufficient air pressure to shift the pump. *Solution:* Make sure the pump is receiving adequate air pressure and that the pump discharge and inlet are free from obstructions.
- No: Either the pump speed is set to a low

value, or the solenoid is incorrectly connected electrically. *Solution:* Make sure the pump speed is reasonable, and recheck electrical connections.

- Auto Fill Jumper is not placed across both pins.

Condition: The LCD screen is operable and the pump is shifting, but little or no fluid is being displaced.

- Verify that the pump is located in such a way that it is within the suction lift capability.
- Verify that sufficient air pressure is supplied to the pump (must be more than liquid discharge pressure).
- Verify that sufficient air volume is supplied to the pump (see pump performance chart).
- Verify that valves on the liquid inlet and discharge lines are open and that other possible restrictions are removed.
- Cavitation may be occurring. Slow pump speed down. Flow rate can dramatically increase when stroke rate is decreased. A slower pump speed allows the check balls to close properly and a larger displacement per stroke to be achieved. Stroke interval for maximum flow rate:
A.025 — .10; A1 — .10; A2 — .20.
- In an attempt to isolate the problem, disconnect the pump from the piping and test pump operation in isolation.

Condition: The unit behaves correctly without, but erratically with external switches.

The external switches may be normally closed or wired incorrectly. The controller requires normally open switches. Check wiring (see page 13A).

FCSII HOOKUP SCHEMATIC

STANDARD INSTALLATION

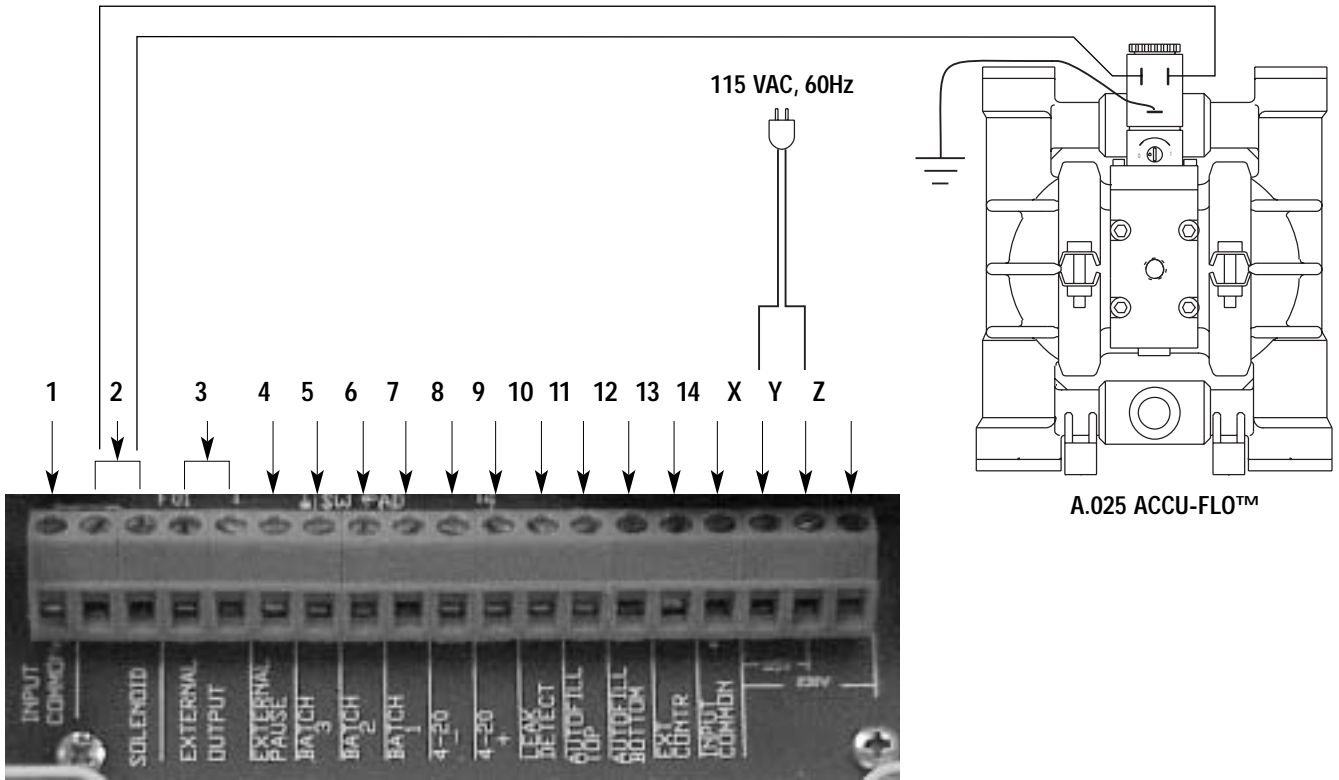

AUTO FILL MODE INSTALLATION

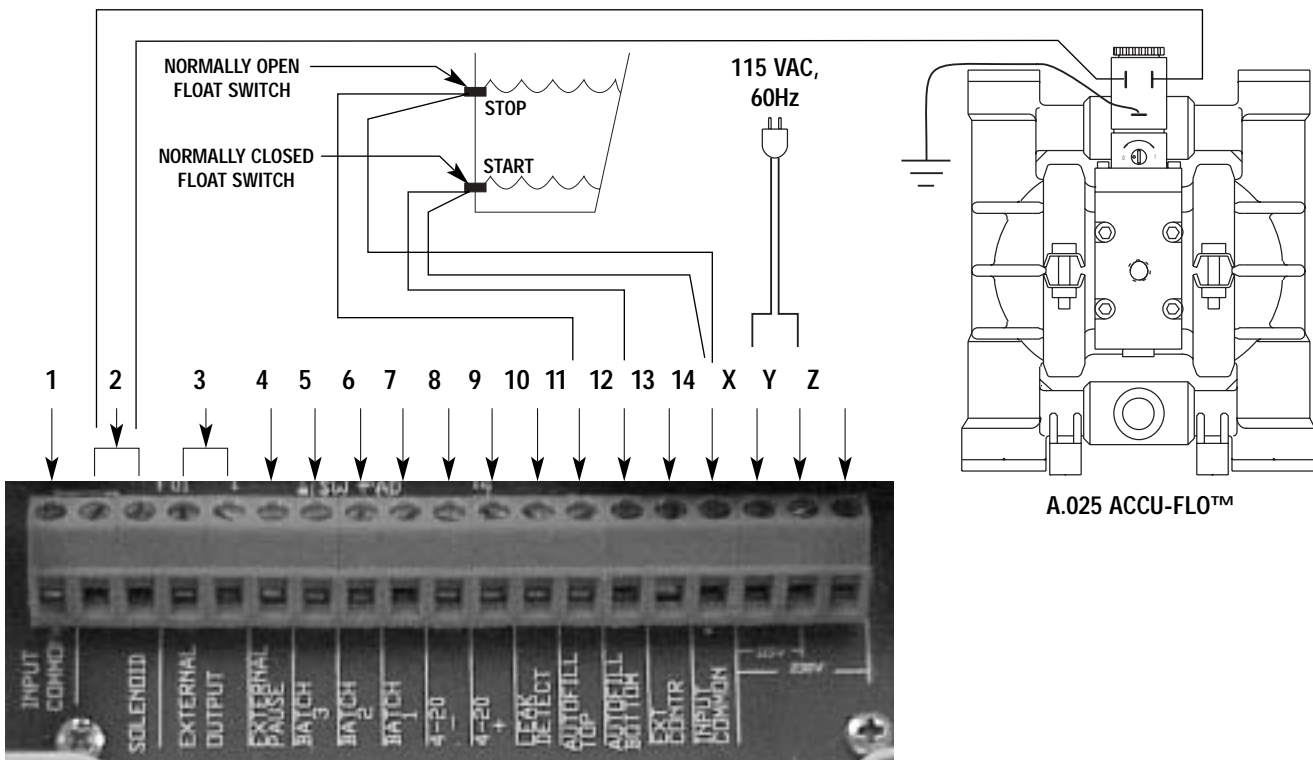

EXTERNAL INPUT SIGNAL EXAMPLES

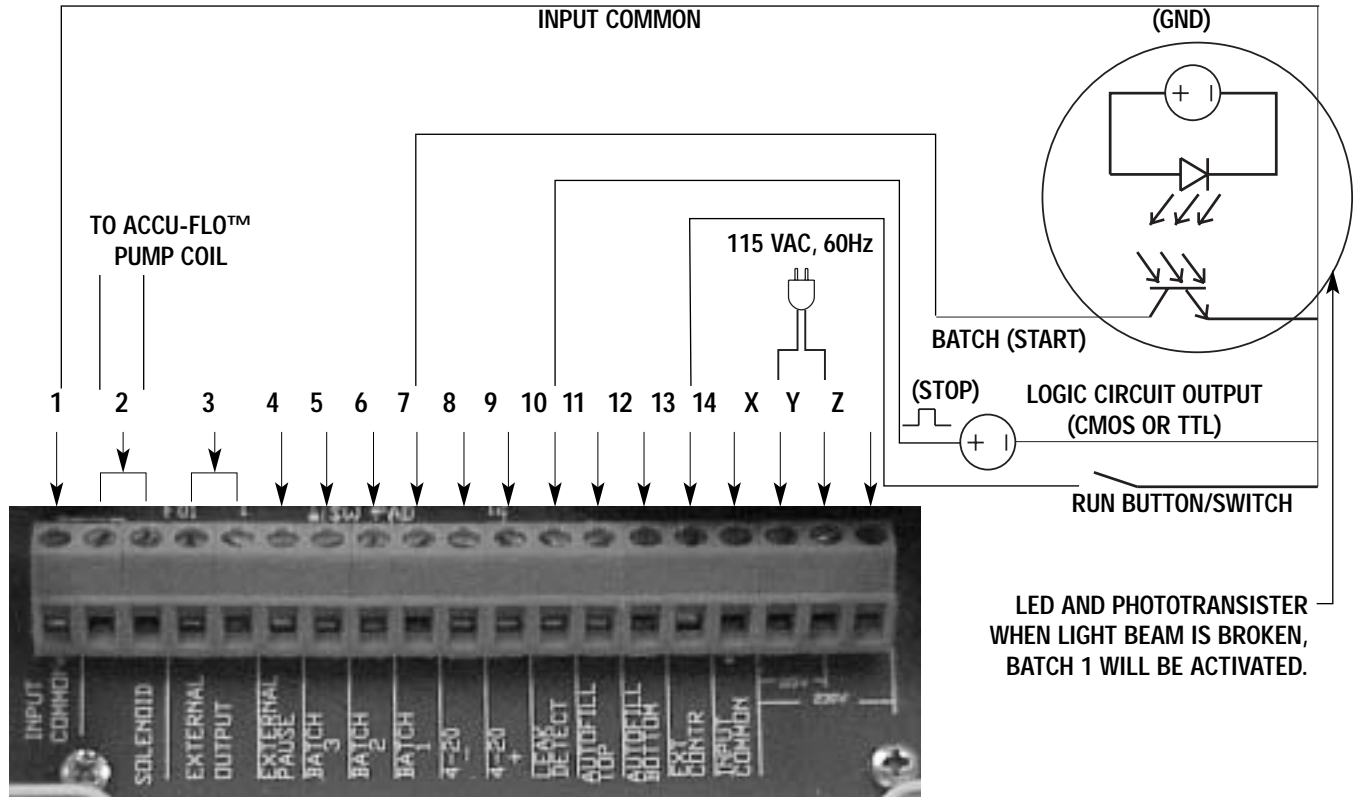

4-20 mA EXTERNAL INPUT

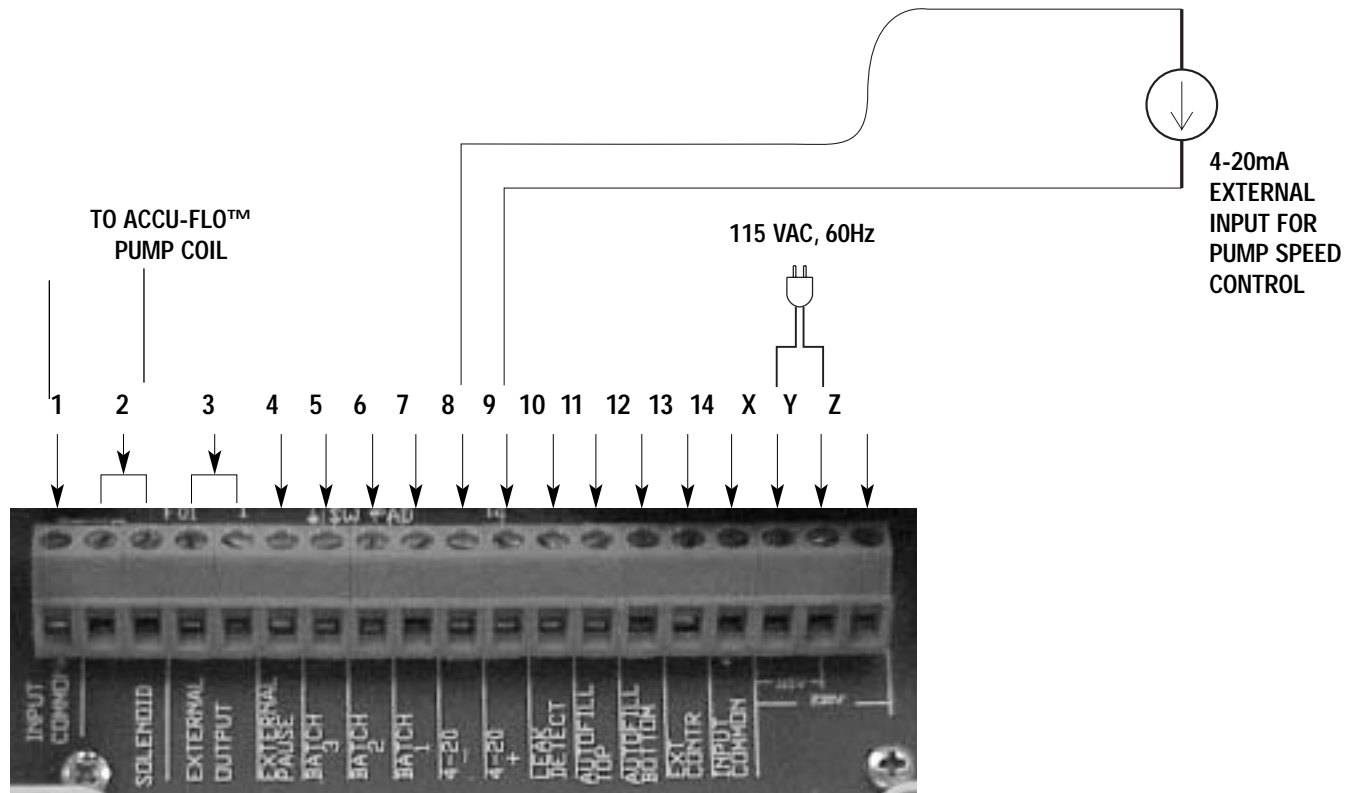

WARRANTY

Each and every product manufactured by Wilden Pump and Engineering, LLC is built to meet the highest standards of quality. Every pump is functionally tested to insure integrity of operation.

Wilden Pump and Engineering, LLC warrants that pumps, accessories and parts manufactured or supplied by it to be free from defects in material and workmanship for a period of one year from date of startup or two years from date of shipment, whichever comes first. Failure due to normal wear, misapplication, or abuse is, of course, excluded from this warranty.

Since the use of Wilden pumps and parts is beyond our control, we cannot guarantee the suitability of any pump or part for a particular application and Wilden Pump and Engineering, LLC shall not be liable for any consequential damage or expense arising from the use or misuse of its products on any application. Responsibility is limited solely to replacement or repair of defective Wilden pumps and parts.

All decisions as to the cause of failure are the sole determination of Wilden Pump and Engineering, LLC.

Prior approval must be obtained from Wilden for return of any items for warranty consideration and must be accompanied by the appropriate MSDS for the product(s) involved. A Return Goods Tag, obtained from an authorized Wilden distributor, must be included with the items which must be shipped freight prepaid.

The foregoing warranty is exclusive and in lieu of all other warranties expressed or implied (whether written or oral) including all implied warranties of merchantability and fitness for any particular purpose. No distributor or other person is authorized to assume any liability or obligation for Wilden Pump and Engineering, LLC other than expressly provided herein.