

TM4, TM6, & TM10

EOM

Engineering
Operation &
Maintenance

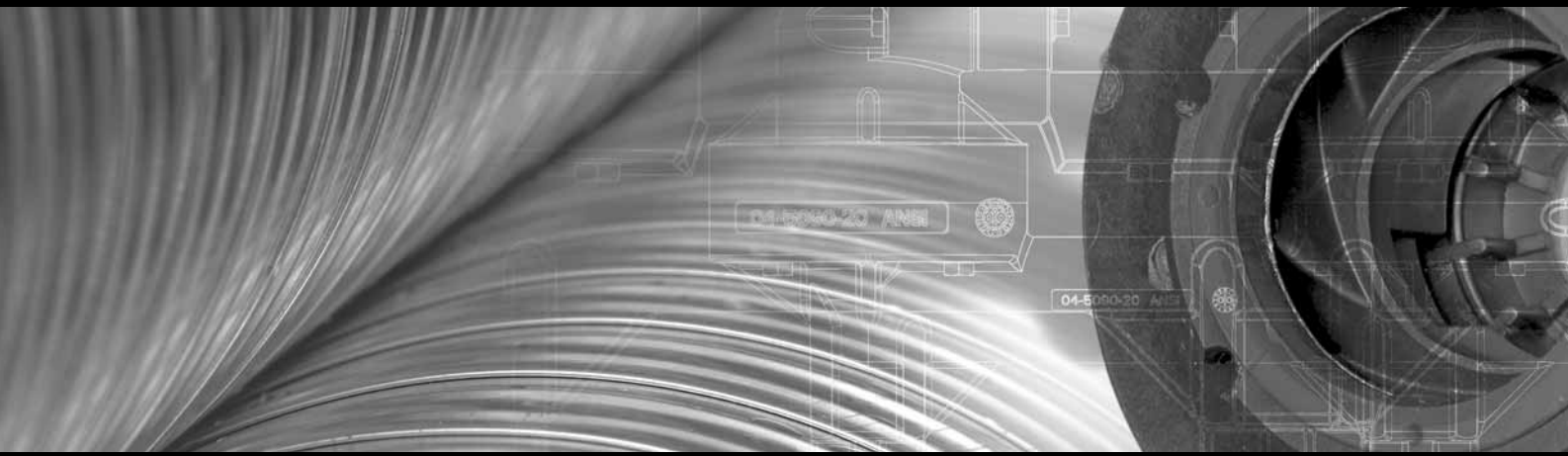

Enhance your process

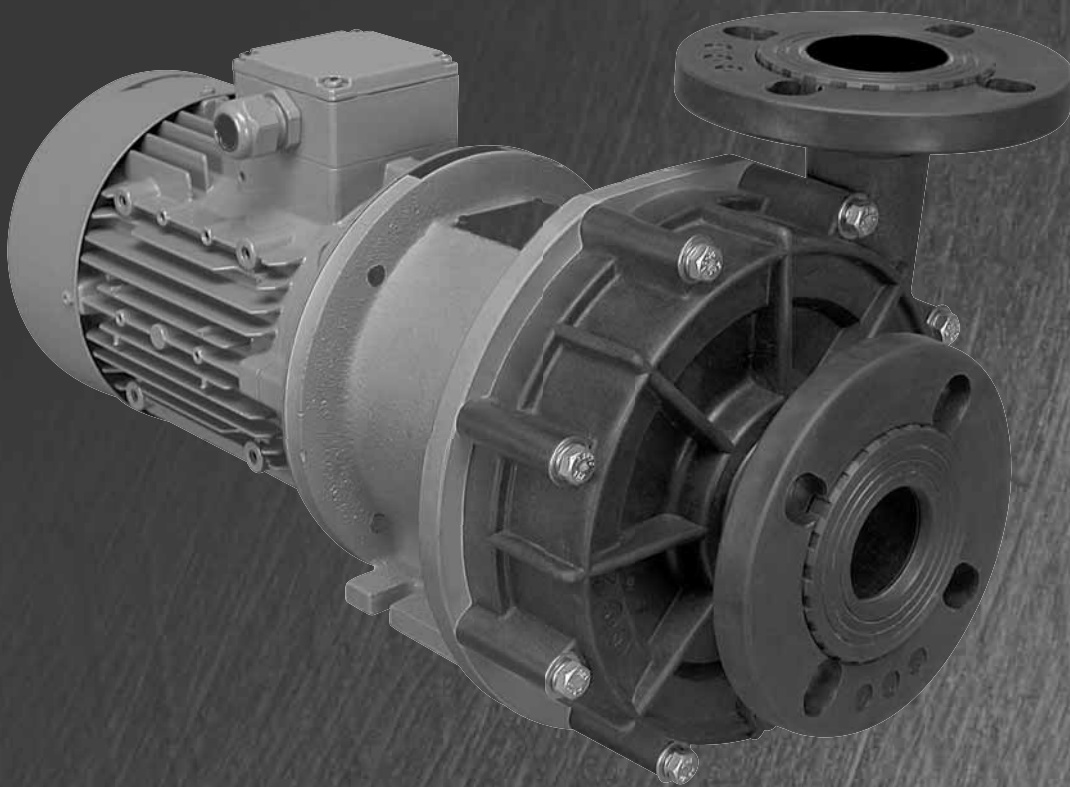

Mag Drive

1/2 HP
through
5 HP



WILDEN®

A DOVER COMPANY

WIL-15010-E-01
REPLACES WIL-13010-E-02

TABLE OF CONTENTS

SECTION 1	CAUTIONS—READ FIRST!	1
SECTION 2	PUMP DESIGNATION SYSTEM	3
SECTION 3	HOW IT WORKS	4
SECTION 4	DIMENSIONAL DRAWINGS	5
SECTION 5	PERFORMANCE	
	A. 0.4 kW (1/2 HP) Performance Curves	
	50 Hz	6
	60 Hz	7
	B. 0.75 kW (1 HP) Performance Curves	
	50 Hz	8
	60 Hz	9
	C. 1.5 kW (2 HP) Performance Curves	
	50 Hz	10
	60 Hz	11
	D. 2.2 kW (3 HP) Performance Curves	
	50 Hz	12
	60 Hz	13
	E. 3.7 kW (5 HP) Performance Curves	
	50 Hz	14
	60 Hz	15
	F. 3.7 kW (5 HP) Oversize Inlet Performance Curves	
	50 Hz	16
	60 Hz	17
SECTION 6	SUGGESTED INSTALLATION, OPERATION & TROUBLESHOOTING	18
SECTION 7	ASSEMBLY / DISASSEMBLY	21
SECTION 8	EXPLODED VIEW & PARTS LISTING	
	Glass-Fiber Reinforced Polypropylene Models	28
	Carbon-Fiber Reinforced ETFE Models	30

T-Mag™

CAUTIONS—READ FIRST!



TEMPERATURE LIMITS

Glass-Fiber Reinforced Polypropylene
0°C (32 F) to 79°C (175°F)
Carbon-Fiber Reinforced ETFE
-100°C (-148°F) to 100°C (212°F)
Viton® -40°C (-40°F) to 177°C (350°F)
EPDM -51°C (-60°F) to 138°C (280°F)



CAUTION: The pump's maximum operating pressure will change with variations in operating temperature and size of the pump. Please refer to table below for the recommended maximum operating pressures for Wilden pumps.

Operating Temperature: °C (°F)	20 (68)	40 (104)	60 (140)	80 (176)
Maximum Pressure: bar (psig)				
0.40 kW (1/2 HP)	3.4 (50)	3.2 (47)	2.9 (43)	2.5 (36)
0.75 kW (1 HP)	4.9 (71)	4.4 (64)	3.7 (54)	2.9 (43)
1.5 kW (2 HP) & 2.2 kW (3 HP)	5.9 (85)	5.4 (78)	4.4 (64)	3.4 (50)
3.7 kW (5 HP)	5.9 (85)	5.4 (78)	4.4 (64)	3.4 (50)

(Above data based on water)



CAUTION: Operating a Wilden pump below the minimum flow rates shown below may result in a significant rise in temperature within the interior of the pump. Operation of the pump below these minimum levels may also result in increased radial and axial forces on the shaft, bushing and impeller assembly. These resulting conditions may affect the pump's performance and service life.

Operating Temperature °C (°F)	20 (68)	40 (104)	60 (140)	80 (176)
Minimum Flow: LPM (GPM)				
0.40 kW (1/2 HP)	15 (4.0)	20 (5.3)	25 (6.6)	30 (7.9)
0.75 kW (1 HP)	15 (4.0)	15 (4.0)	20 (5.3)	20 (5.3)
1.5 kW (2 HP) & 2.2 kW (3 HP)	20 (5.3)	20 (5.3)	30 (7.9)	40 (10.6)
3.7 kW (5 HP)	30 (7.9)	30 (7.9)	50 (13.2)	75 (19.8)

(Above data based on water)



CAUTION: Do not run the pump without fluid for extended periods of time. Depending upon application conditions, dry-running the pump may cause the temperature of the internal components to rise, resulting in damage to the pump internals.



CAUTION: When selecting a pump for a specific application be sure to consider the concentration of the fluid being pumped. Changes in fluid concentration may affect viscosity and specific gravity. Other physical properties, such as corrosiveness, may also change with variations in fluid concentration.



CAUTION: Mag-drive pumps are generally intended for use with fluids with little or no particulate in the process. Excessive or large particulates in the process media will adversely affect pump performance and service life. For process media with more than 5% by volume particulates or with solids larger than 50µ (microns), it is recommended that you use a Wilden air-operated double-diaphragm pump. For process media with 5% or less by volume particulates and with solids smaller than 50µ, it is recommended that you use the Sintered SiC bearing option in the Wilden pump. However, please note that a reduced service life may still be experienced versus a fluid process with no particulate.



WARNING: Always perform an exterior inspection of the pump prior to installation. Look for damage that may have been inflicted during shipment. Also, check the free rotation of the pump by using a small flat head screwdriver to turn the fan motor.



WARNING: Inspect the pump nameplate prior to installation to insure the proper materials of construction, motor power rating, impeller dimension and fluid connection sizes.



WARNING: Always prime pump before start-up. Lack of fluid at start-up may cause excessive heat build-up within the pump which may cause a reduction in service life of the components. Also, insure that all inlet process valves are open at start-up.



CAUTION: At initial start-up of the pump, after complete and proper wiring of the unit, check the pump rotation by quickly turning on and then off the pump power. After shut down, inspect the fan rotation through the back fan guard. While looking through the rear motor fan guard, the fan should be rotating clockwise. Once proper rotation has been established, follow all start-up procedures for the system.











WARNING: During a systems or plant wide power failure, always turn off all rotating equipment to prevent sudden increases in system pressures once power is restored.



WARNING: Before normal shut down of the pump for service or at the completion of a process run, always slowly close the discharge valve of the pump to prevent reverse flow from the discharge lines. Once the discharge valve is closed, immediately shut down the pump.

CAUTIONS—READ FIRST! CONT.

-  **CAUTION:** Periodically inspect the interior of the pump for damage or wear, especially when the pump is being used with a fluid near its freezing point. In some cases the fluid may crystallize even when the pump is only shut down for a short period. Use of an automatic drain system or heat tracing may be used to counter this process.
-  **CAUTION:** When choosing pump materials, be sure to check the temperature limits for all wetted components. Example: Viton® has a limit of 177°C (350°F), but Carbon-Filled Polypropylene has a maximum limit of only 79°C (175°F).
-  **CAUTION:** Maximum temperature limits are based upon mechanical stress only. Certain chemicals will significantly reduce maximum safe operating temperatures. Consult Chemical Resistance Guide (E4) for chemical compatibility and temperature limits.
-  **WARNING:** Prevention of static sparking - If static sparking occurs, fire or explosion could result. Pump, valves, and containers must be grounded to a proper grounding point when handling flammable fluids or whenever discharge of static electricity is a hazard. For Wilden pumps, only PVDF and ETFE models offer statically dissipative materials. Check with your local, state or government agencies for grounding requirements for your area.
-  **CAUTION:** The process fluid and cleaning fluids must be chemically compatible with all wetted components. See Chemical Compatibility Guide (E4) for details.
-  **CAUTION:** Never disconnect any fluid process lines that may contain pressurized fluid. Be sure to close any isolation valves and safely drain any line pressure before servicing pump. Failure to do so may result in process fluid being sprayed from a loosened connection.
-  **CAUTION:** Never attempt to reuse damaged pump components. If the impeller, casing, bushing or any other internal parts show signs of wear, replace them immediately with factory approved spare parts. Using damaged parts may result in process fluid leaks or bodily injury.
-  **CAUTION:** With an increase in specific gravity the required torque to turn the impeller increases as well. The increase in torque needed can exceed the magnet's ability rotate the impeller of pump resulting in little or no flow.
-  **CAUTION:** When installing a Wilden Mag-Drive pump into an application requiring an ATEX pump, an ATEX certified motor must be used.

WILDEN PUMP DESIGNATION SYSTEM

MAG-DRIVE

LEGEND

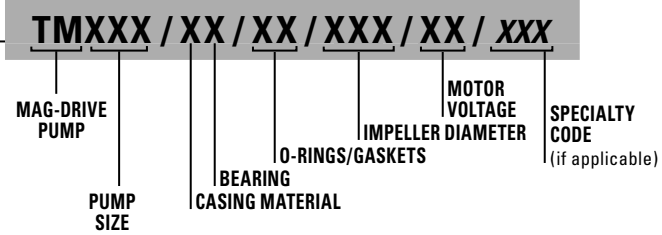

MATERIAL CODES

PUMP SIZE

- 4HE = 38mm (1-1/2") Inlet and Discharge, 0.40 kW (1/2 HP), IEC B5 Mount, D71D Frame
- 4KE = 38mm (1-1/2") Inlet and Discharge, 0.75 kW (1 HP), IEC B5 Mount, D80D Frame
- 6LE = 51mm (2") Inlet, 38mm (1-1/2") Discharge, 1.50 kW (2 HP), IEC B5 Mount, D90SD Frame
- 6ME = 51mm (2") Inlet, 38mm (1-1/2") Discharge, 2.20 kW (3 HP), IEC B5 Mount, D90LD Frame
- 6NE = 51mm (2") Inlet, 38mm (1-1/2") Discharge, 3.70 kW (5 HP), IEC B5 Mount, DF112MD Frame
- 10NE = 64mm (2-1/2") Inlet, 51mm (2") Discharge, 3.70 kW (5 HP), IEC B5 Mount, DF112MD Frame

NOTE: For C-Face frame motors, replace "E" with "C" in the pump size designation. See chart below for C-Face configuration.

SIZE	FRAME
1/2 HP	56C
1 HP	56C
2 HP	145TC
3 HP	145TC
5 HP	184TC

CASING MATERIAL

- P = GLASS-FILLED POLYPROPYLENE- BLACK
- E = CONDUCTIVE ETFE - BLACK

BEARING*

- C = CARBON
- R = RULON® (FILLED PTFE)
- A = 995 CERAMIC (AL2O3)
- S = SINTERED SiC (CERAMIC)

O-RINGS / GASKETS **

- VT = VITON®
- ND = EPDM

IMPELLER DIAMETER

ACTUAL MM SIZE SHOWN

NOTE:

- 1) Standard orders are shipped with impellers that have not been trimmed and are at maximum size.
- 2) All impeller diameters shown in "mm" size and are variable in one (1) millimeter increments.
- 3) Proper impeller selection is determined by the system parameters. Consult factory for details.
- 4) Proper impeller size is effected by motor rpm.
- 5) Orders for units with trimmed impeller will be changed out at the factory before shipment.

MOTOR VOLTAGE

- AA = 110/220V - 1 PHASE - 60 HZ - TEFC
- AB = 110/220V - 1 PHASE - 50 HZ - TEFC
- BA = 208-230/460V or 575V - 3 PHASE - 60 HZ - TEFC
- CB = 230/460V - 3 PHASE - 50 HZ - TEFC
- XX = SPECIAL MOTOR (CONSULT FACTORY)
- YY = PUMP HEAD ONLY+
- ZZ = NO MOTOR, WITH MOUNTING BRACKET AND OUTER MAGNET

BEARING/BUSHINGS DETAIL *

	Bearing	Shaft	Wear Ring	Front Thrust Ring	Rear Thrust Ring
C	Carbon	995 Al Ceramic	Carbon	995 Al Ceramic	995 Al Ceramic
R	Rulon	995 Al Ceramic	Rulon	995 Al Ceramic	995 Al Ceramic
A	995 Al Ceramic	995 Al Ceramic	Rulon	995 Al Ceramic	995 Al Ceramic
S	Sintered Sic	Sintered Sic	Sintered Sic	Sintered Sic	Sintered Sic

SPECIALTY CODES

NO SPECIALTY CODES AVAILABLE AT THIS TIME, CONSULT FACTORY.

NOTE: All pump flanges are ANSI, DIN and JIS Combination.

*C is the standard bearing/bushing configuration as this is the only configuration with the dry-run option.

All other materials are special order.

** VT is the standard elastomer, ND is a special order elastomer and requires factory quote.

+ Pump head only is a complete wet end kit with no motor, no mounting bracket, no outer magnet and no base.

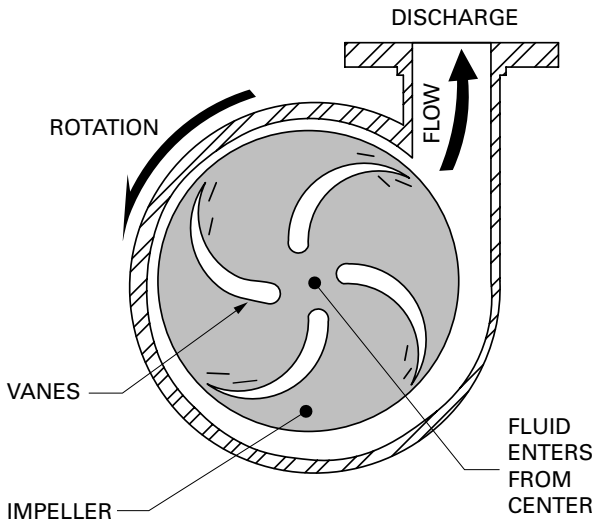

FIGURE 1: PUMP LIQUID END

Fluid is moved by a centrifugal pump through the use of centrifugal force. Fluid is taken into the center of the impeller through the inlet connection. Most centrifugal pumps prefer a positive inlet pressure to prevent cavitation (lack of enough positive inlet pressure to prevent liquid vaporization). This fluid is then caught by the vanes of the impeller as it spins. This rotation of the fluid mechanically by the vanes “throws” the fluid to the outside of the impeller and toward the discharge port of the liquid end of the pump. This mechanical movement of the fluid creates the discharge pressure of the pump. Variables like inlet fluid supply pressure, impeller diameter, motor horsepower and closed face versus open face all effect the flow and pressure of the pump. Each of these variables can be manipulated to achieve a desired flow and/or pressure.

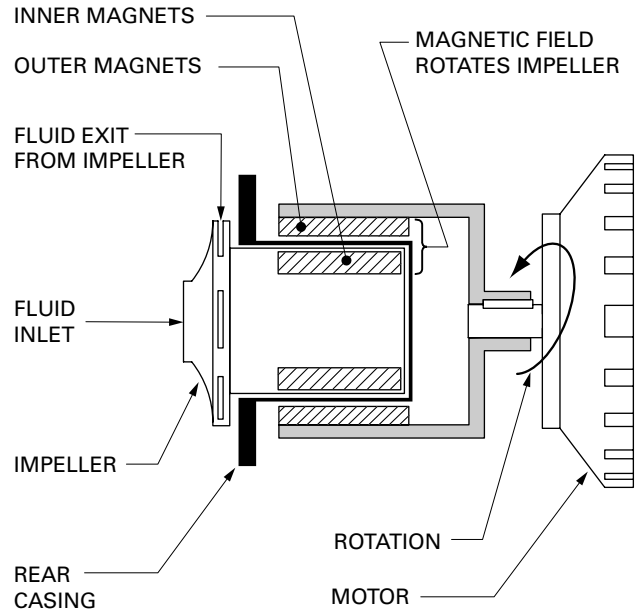
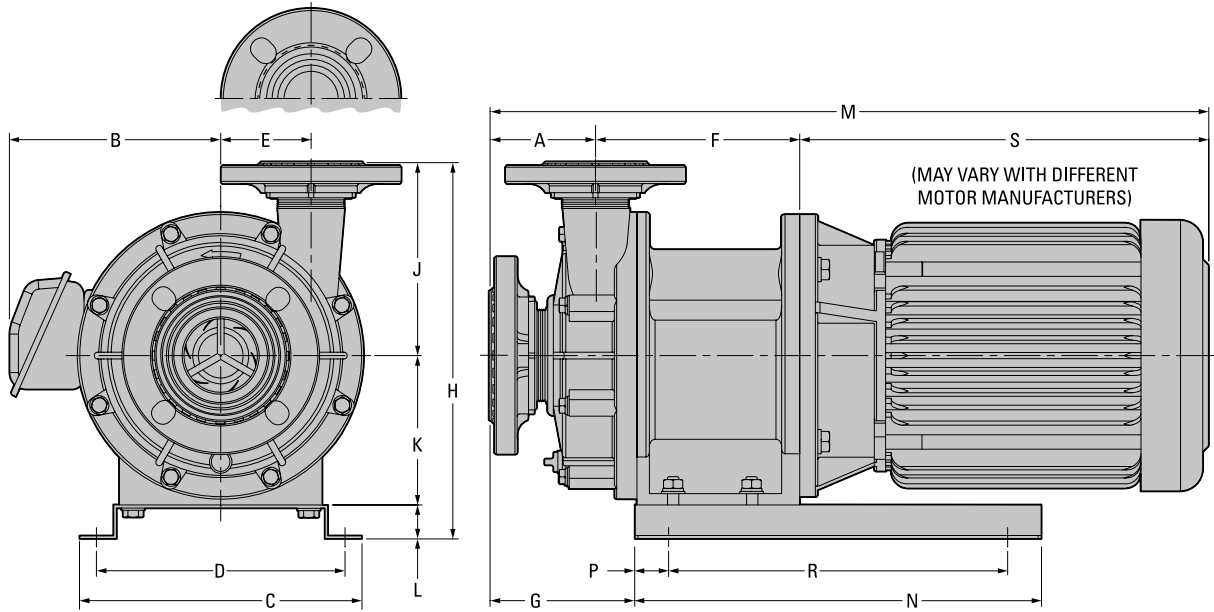

FIGURE 2: PUMP MAGNETIC DRIVE

A magnetic drive pump uses a balanced magnetic field to create the rotation of the fluid impeller. Unlike a traditional centrifugal pump which has a direct drive connection between impeller and motor, a mag-drive pump eliminates the direct drive mechanism and replaces it with a magnetic field. An outer magnetic bell housing is mounted on the end of the pump shaft. This outer bell is aligned on the outside of the rear casing. The pump impeller is connected to a smaller magnet assembly and rides on an internal shaft and bushing assembly. (The liquid end parts are all isolated within the fluid head of the pump without the need for a mechanical seal.) The smaller magnet assembly is mounted within the center of the magnetic field of the outer bell housing. Although these two magnet assemblies are separated by a fluid barrier, the magnetic fields are aligned. When the pump motor is started the outer bell housing begins to rotate. As the outer bell rotates, the rotating magnetic field effects the inner impeller magnet. As the two magnets begin to turn together, the impeller begins turning and displacing fluid.

DIMENSIONAL DRAWINGS



DIMENSIONS

mm (in)	Model Size					
	1/2 HP	1 HP	2 HP	3 HP	5 HP	5 HP
A	89 (3.5)	131 (5.2)	90 (3.5)	90 (3.5)	90 (3.5)	94 (3.7)
B	130 (5.1)	142 (5.6)	155 (6.1)	155 (6.1)	187 (7.4)	187 (7.4)
C	225 (8.9)	160 (6.3)	260 (10.2)	260 (10.2)	250 (9.8)	250 (9.8)
D	195 (7.7)	130 (5.1)	204 (8.0)	204 (8.0)	220 (8.7)	220 (8.7)
E	60 (2.4)	72 (2.8)	80 (3.1)	80 (3.1)	80 (3.1)	80 (3.1)
F	142 (5.6)	146 (5.7)	160 (6.3)	160 (6.3)	175 (6.9)	180 (7.1)
G	116 (4.6)	150 (5.9)	138 (5.4)	138 (5.4)	119 (4.7)	128 (5.0)
H	286 (11.3)	256 (10.1)	281 (11.1)	281 (11.1)	323 (12.7)	323 (12.7)
J	141 (5.6)	141 (5.6)	161 (6.3)	161 (6.3)	161 (6.3)	171 (6.7)
K	118 (4.6)	85 (3.3)	90 (3.5)	90 (3.5)	132 (5.2)	132 (5.2)
L	25 (1.0)	30 (1.2)	30 (1.2)	30 (1.2)	30 (1.2)	30 (1.2)
M	467 (18.4)	481 (18.9)	564 (22.2)	564 (22.2)	627 (24.7)	636 (25.0)
N	230 (9.1)	210 (8.3)	300 (11.8)	300 (11.8)	360 (14.2)	360 (14.2)
P	25 (1.0)	35 (1.4)	20 (0.8)	20 (0.8)	30 (1.2)	30 (1.2)
R	180 (7.1)	130 (5.1)	200 (7.9)	200 (7.9)	300 (11.8)	300 (11.8)
S	236 (9.3)	232 (9.1)	311 (12.2)	311 (12.2)	362 (14.3)	362 (14.3)
Flange (ANSI, DIN & JIS Combo)						
In	40 (1-1/2)	40 (1-1/2)	50 (2)	50 (2)	50 (2)	65 (2-1/2)
Out	40 (1-1/2)	40 (1-1/2)	40 (1-1/2)	40 (1-1/2)	40 (1-1/2)	50 (2)

Note: The total length & weight of the pump will differ depending on the brand of the motor.

0.4 kW (1/2 HP) - 50 Hz [TM4H] - 2900 RPM

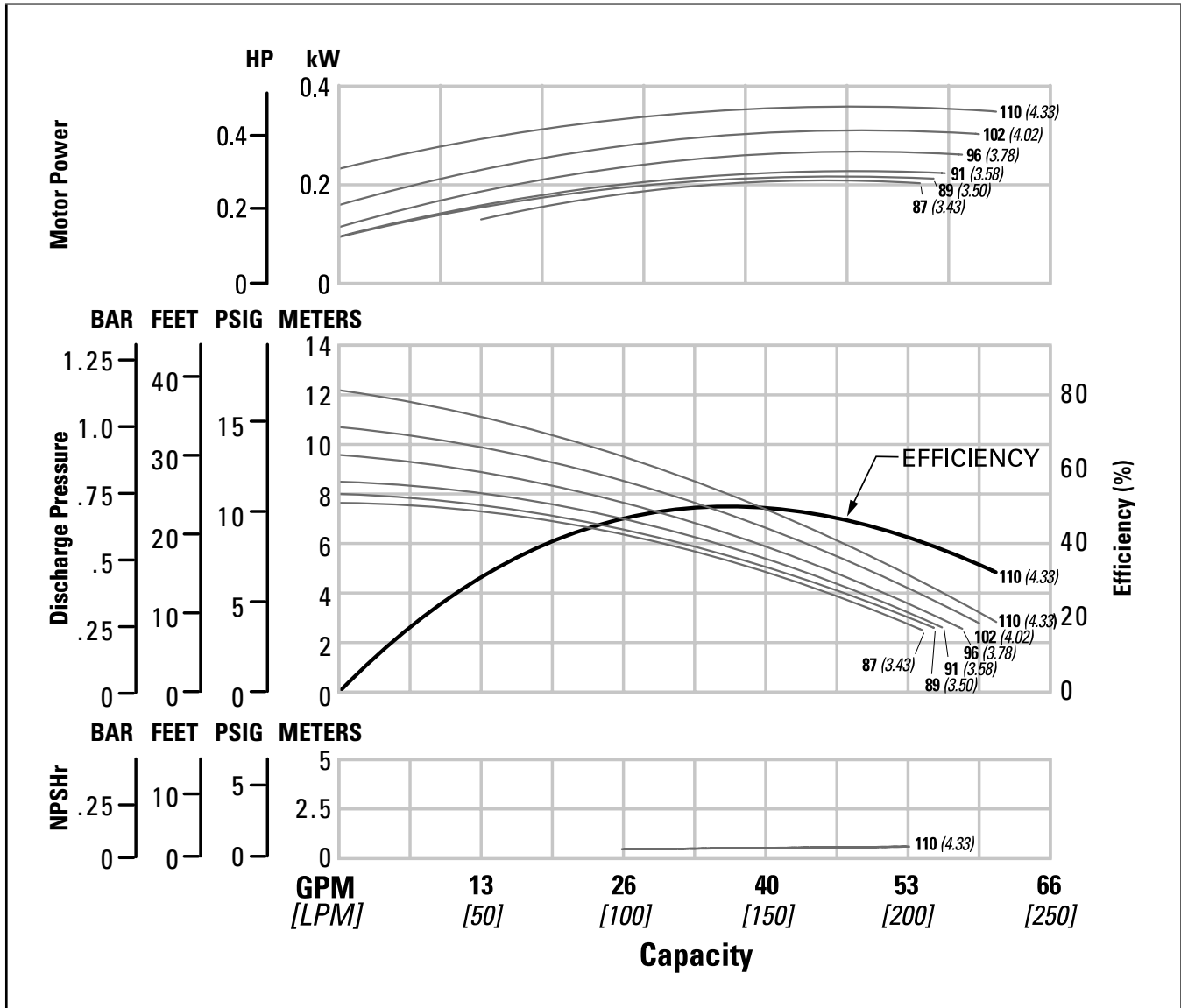

Height 286 mm (11.3")
 Width 260 mm (10.2")
 Length 467 mm (18.4")
 Ship Weight
 GFR-PP 18 kg (40 lbs)
 CFR-ETFE 19 kg (42 lbs)
 Fluid Inlet 38 mm (1-1/2")
 Fluid Discharge 38 mm (1-1/2")
 Rated Point 125 lpm (33 gpm)
 0.8 bar (11.6 psig)

All curves based upon pumping water at sea level, specific gravity 1.0, ambient temperature 20°C (68°F).

NOTE: Numbers shown to far right of all performance lines denote the diameter of the pump impeller [millimeters (inches)]. Consult factory for availability of impeller trim sizes other than shown.

PERFORMANCE

0.4 kW (1/2 HP) - 60 Hz [TM4H] - 3600 RPM

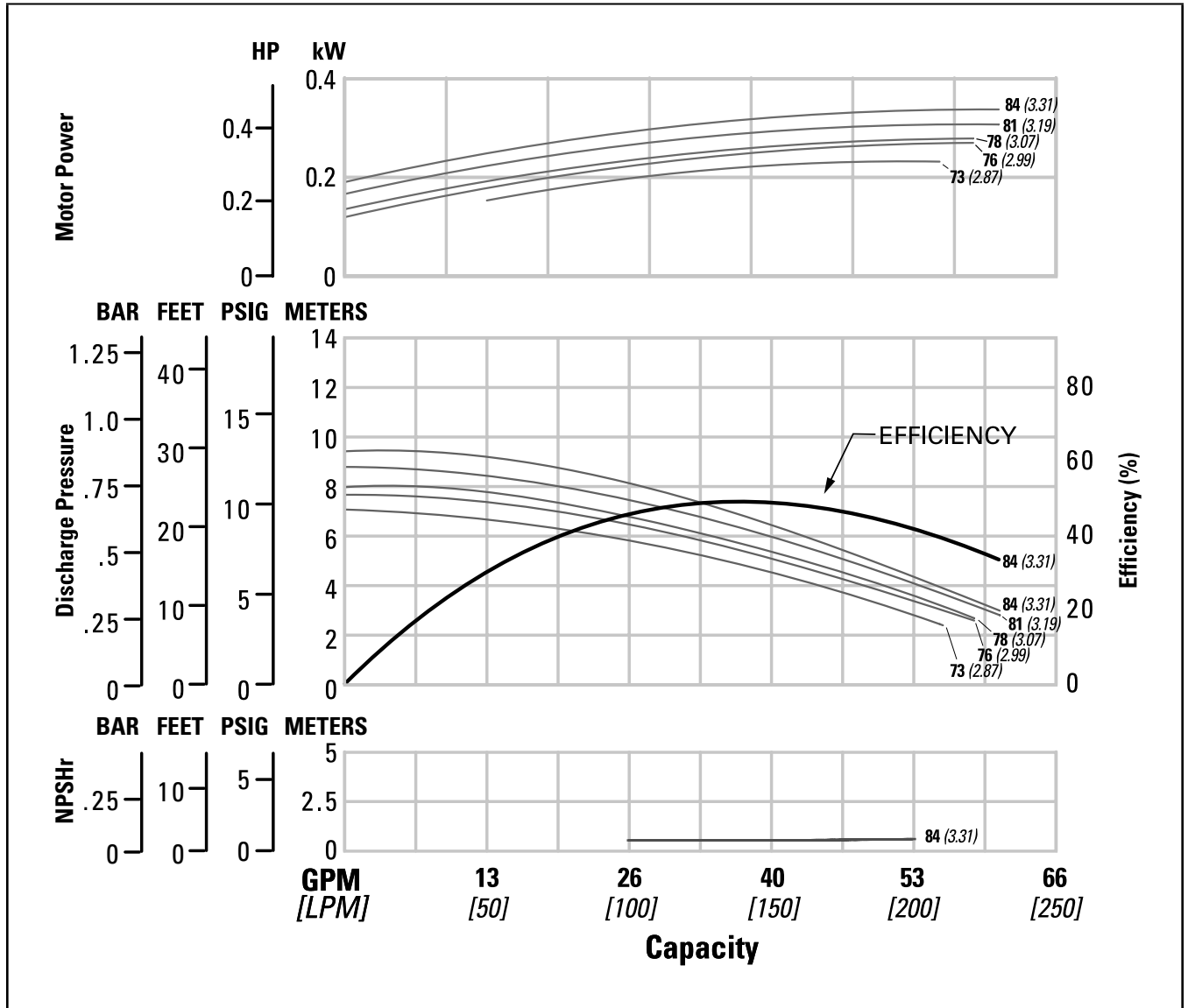

Height 286 mm (11.3")
 Width 260 mm (10.2")
 Length 467 mm (18.4")
 Ship Weight
 GFR-PP 18 kg (40 lbs)
 CFR-ETFE 19 kg (42 lbs)
 Fluid Inlet 38 mm (1-1/2")
 Fluid Discharge 38 mm (1-1/2")
 Rated Point 125 lpm (33 gpm)
 0.68 bar (9.9 psig)

All curves based upon pumping water at sea level, specific gravity 1.0, ambient temperature 20°C (68°F).

NOTE: Numbers shown to far right of all performance lines denote the diameter of the pump impeller [millimeters (inches)]. Consult factory for availability of impeller trim sizes other than shown.

0.75 kW (1 HP) - 50 Hz [TM4K] - 2900 RPM

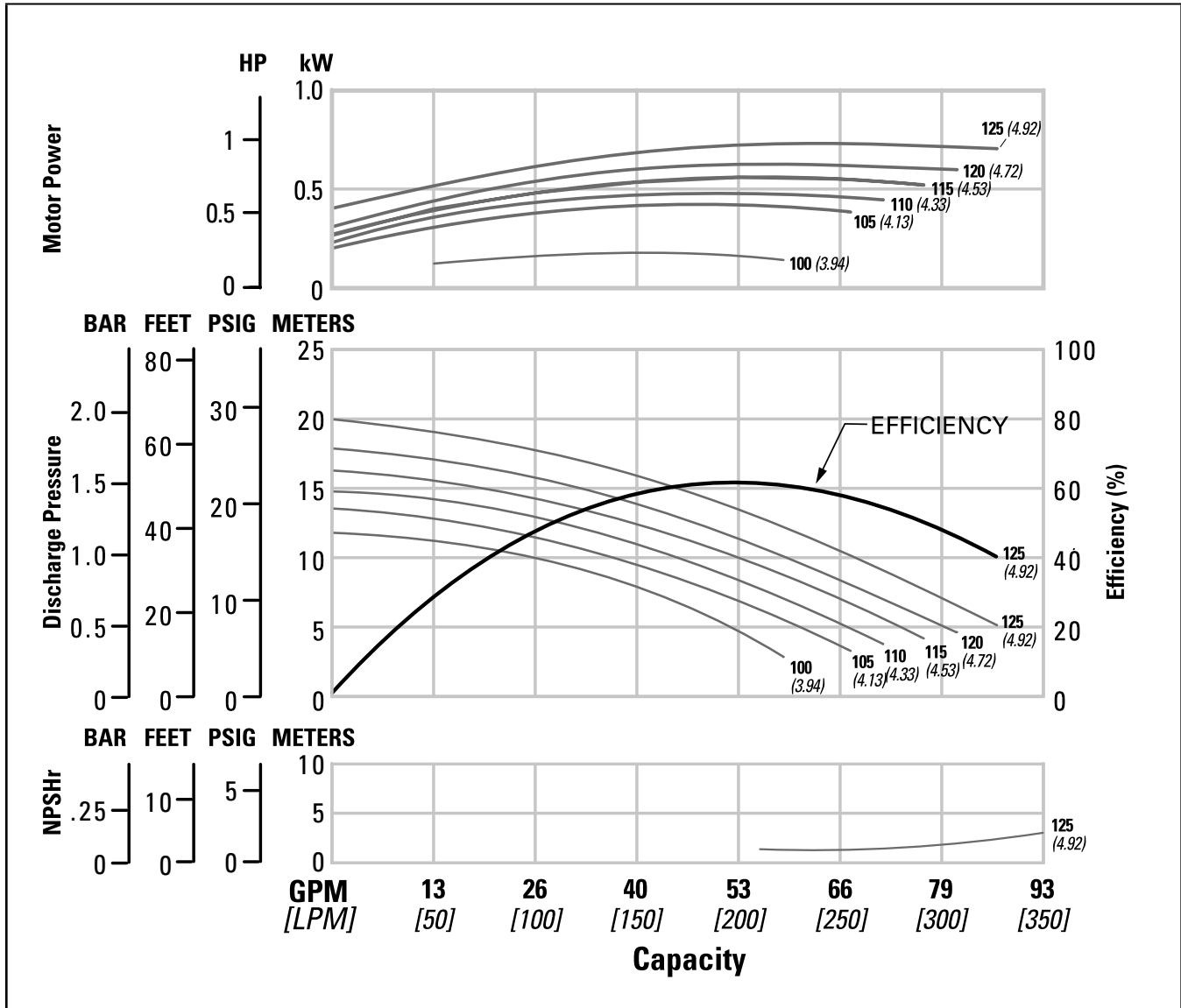

Height256 mm (10.1")
 Width284 mm (11.2")
 Length.....481 mm (18.9")
 Ship Weight
 GFR-PP.....24 kg (53 lbs)
 CFR-ETFE.....25 kg (55 lbs)
 Fluid Inlet.....38 mm (1-1/2")
 Fluid Discharge38 mm (1-1/2")
 Rated Point150 lpm (39.6 gpm)
 1.57 bar (22.8 psig)

All curves based upon pumping water at sea level, specific gravity 1.0, ambient temperature 20°C (68°F).

NOTE: Numbers shown to far right of all performance lines denote the diameter of the pump impeller in [millimeters (inches)]. Consult factory for availability of impeller trim sizes other than shown.

PERFORMANCE

0.75 kW (1 HP) - 60 Hz [TM4K] - 3600 RPM

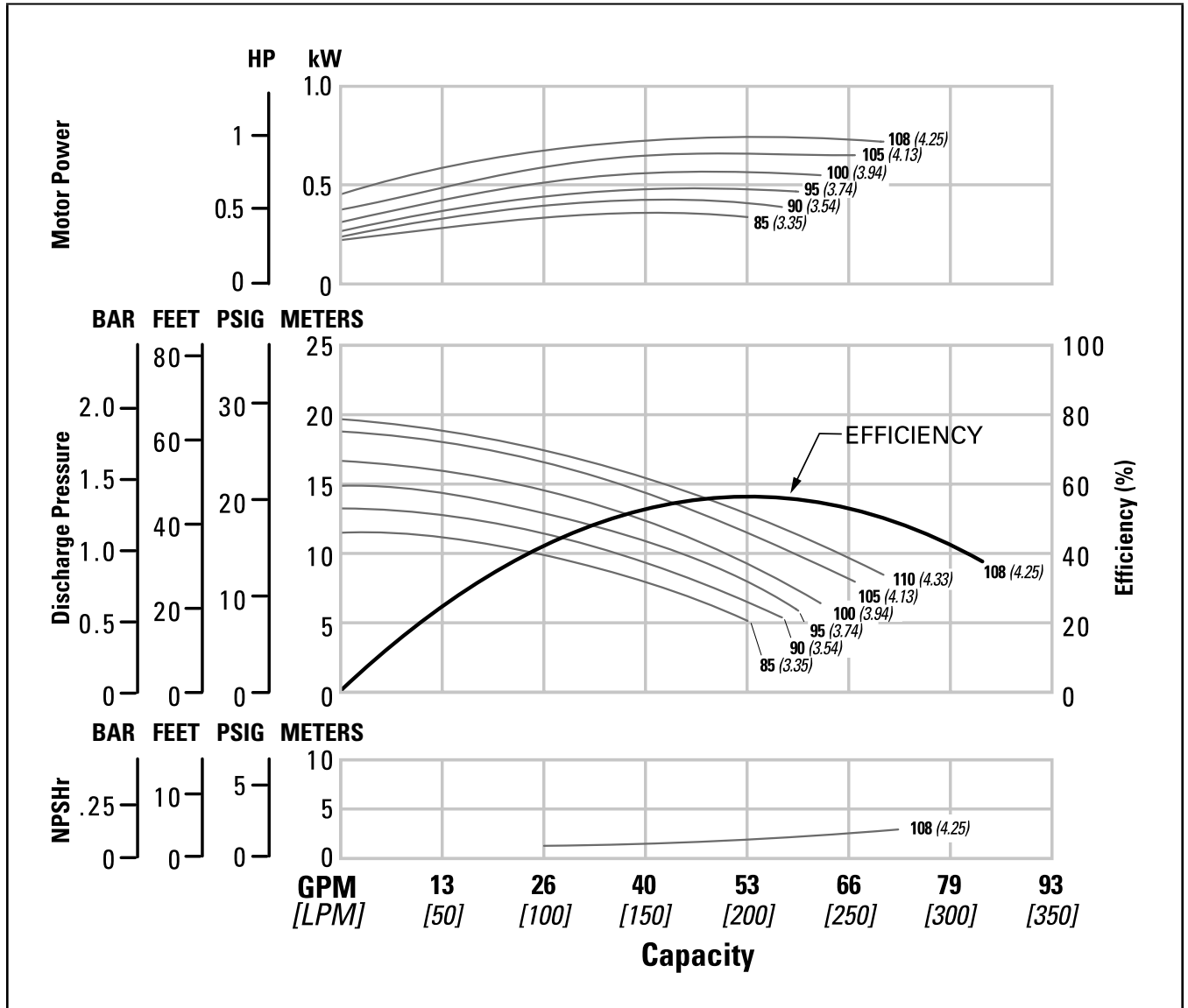

Height256 mm (10.1")
 Width 284 mm (11.2")
 Length..... 481 mm (18.9")
 Ship Weight
 GFR-PP.....24 kg (33 lbs)
 CFR-ETFE.....25 kg (55 lbs)
 Fluid Inlet..... 38 mm (1-1/2")
 Fluid Discharge 38 mm (1-1/2")
 Rated Point 150 lpm (39.6 gpm)
 1.51 bar (21.9 psig)

All curves based upon pumping water at sea level, specific gravity 1.0, ambient temperature 20°C (68°F).

NOTE: Numbers shown to far right of all performance lines denote the diameter of the pump impeller in [millimeters (inches)]. Consult factory for availability of impeller trim sizes other than shown.

1.5 kW (2 HP) - 50 Hz [TM6L] - 2900 RPM

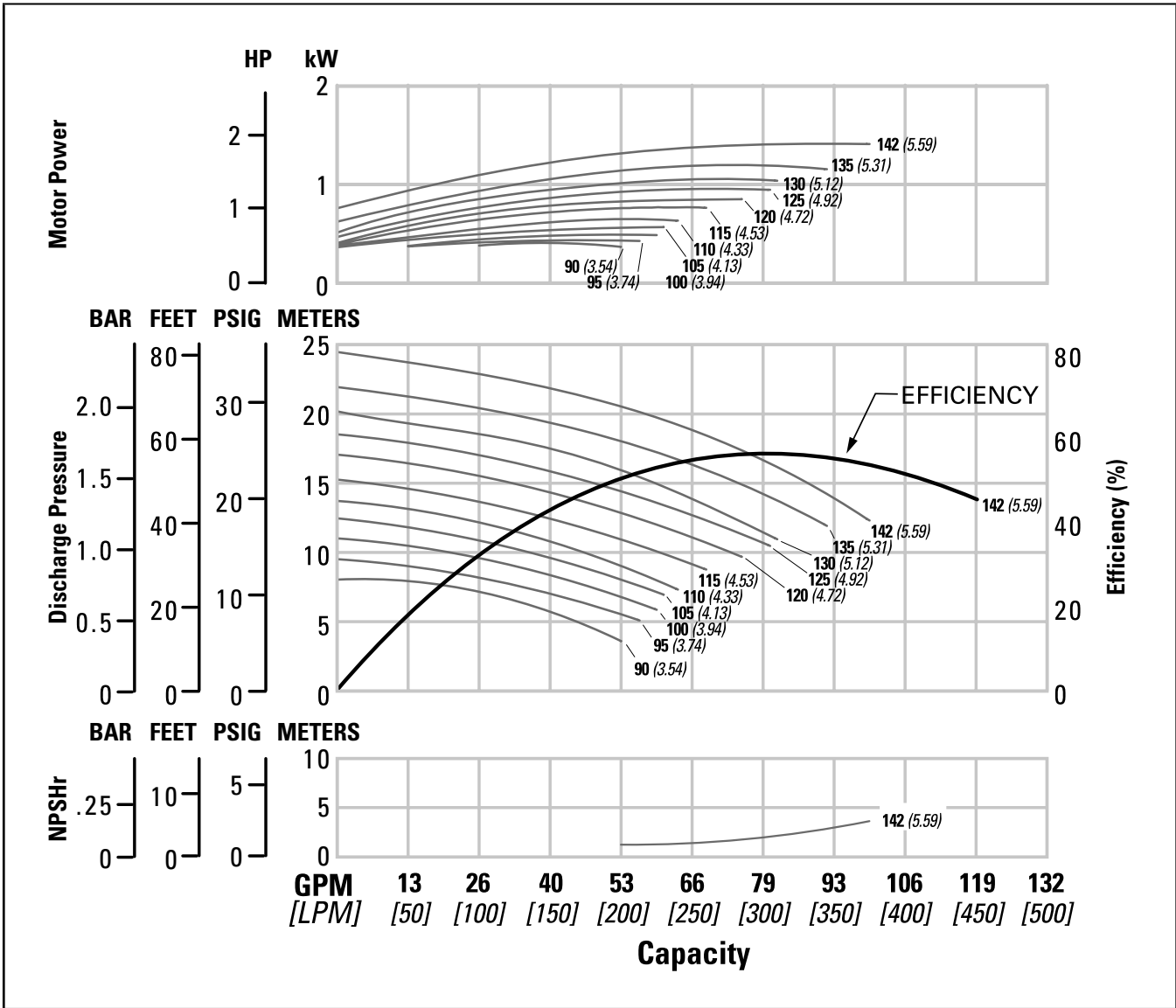

Height 281 mm (11.1")
 Width 305 mm (12.0")
 Length 564 mm (22.2")
 Ship Weight
 GFR-PP 35 kg (77 lbs)
 CFR-ETFE 36 kg (79 lbs)
 Fluid Inlet 51 mm (2")
 Fluid Discharge 38 mm (1-1/2")
 Rated Point 200 lpm (52.8 gpm)
 2.02 bar (29.3 psig)

All curves based upon pumping water at sea level, specific gravity 1.0, ambient temperature 20°C (68°F).

NOTE: Numbers shown to far right of all performance lines denote the diameter of the pump impeller in [millimeters (inches)]. Consult factory for availability of impeller trim sizes other than shown.

1.5 kW (2 HP) - 60 Hz [TM6L] - 3600 RPM

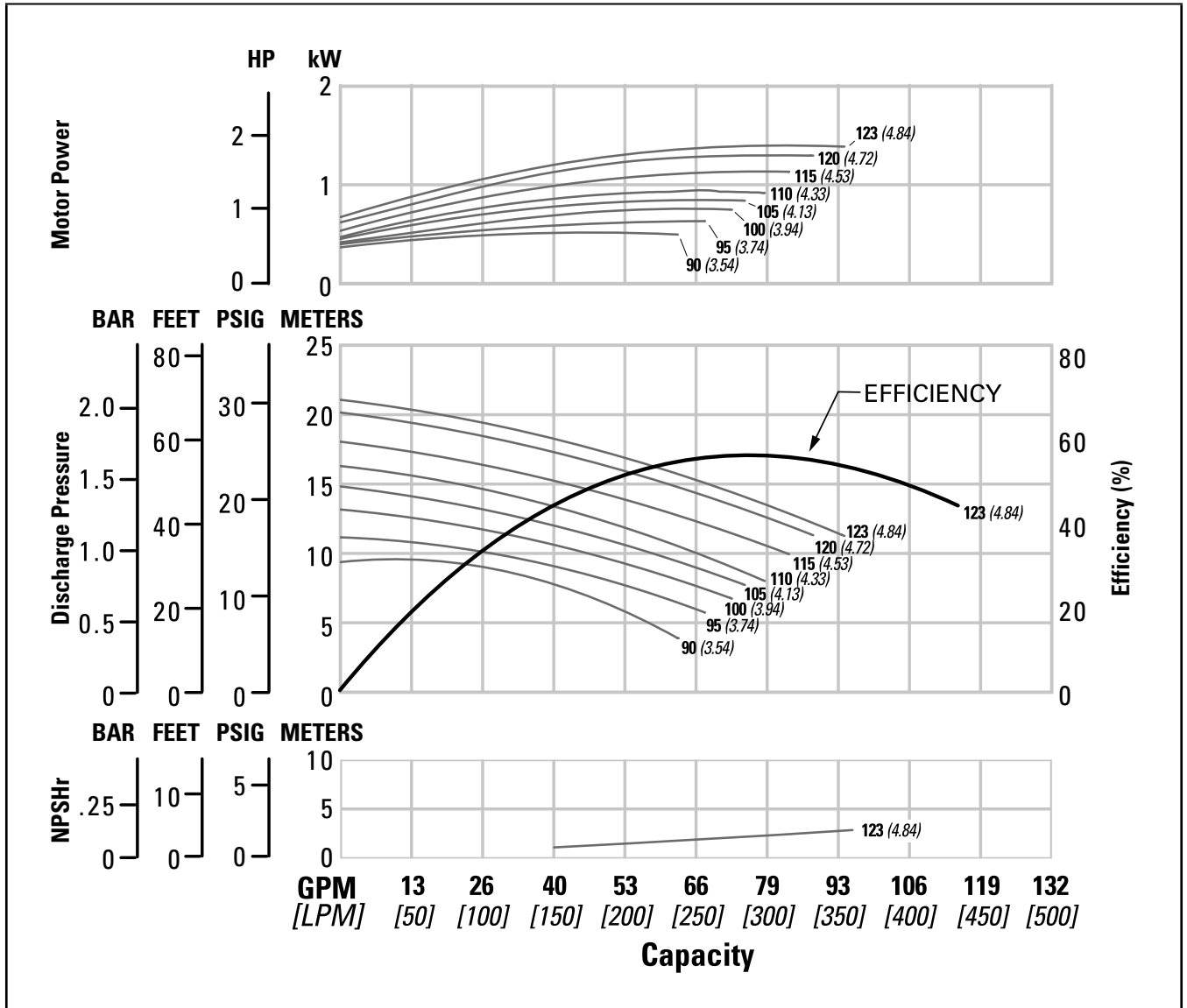

Height 281 mm (11.1")
 Width 305 mm (12.0")
 Length 564 mm (22.2")
 Ship Weight
 GFR-PP 35 kg (77 lbs)
 CFR-ETFE 36 kg (79 lbs)
 Fluid Inlet 51 mm (2")
 Fluid Discharge 38 mm (1-1/2")
 Rated Point 200 lpm (52.8 gpm)
 1.99 bar (28.9 psig)

All curves based upon pumping water at sea level, specific gravity 1.0, ambient temperature 20°C (68°F).

NOTE: Numbers shown to far right of all performance lines denote the diameter of the pump impeller in [millimeters (inches)]. Consult factory for availability of impeller trim sizes other than shown.

3.7 kW (5 HP) - 50 Hz [TM6N] - 2900 RPM

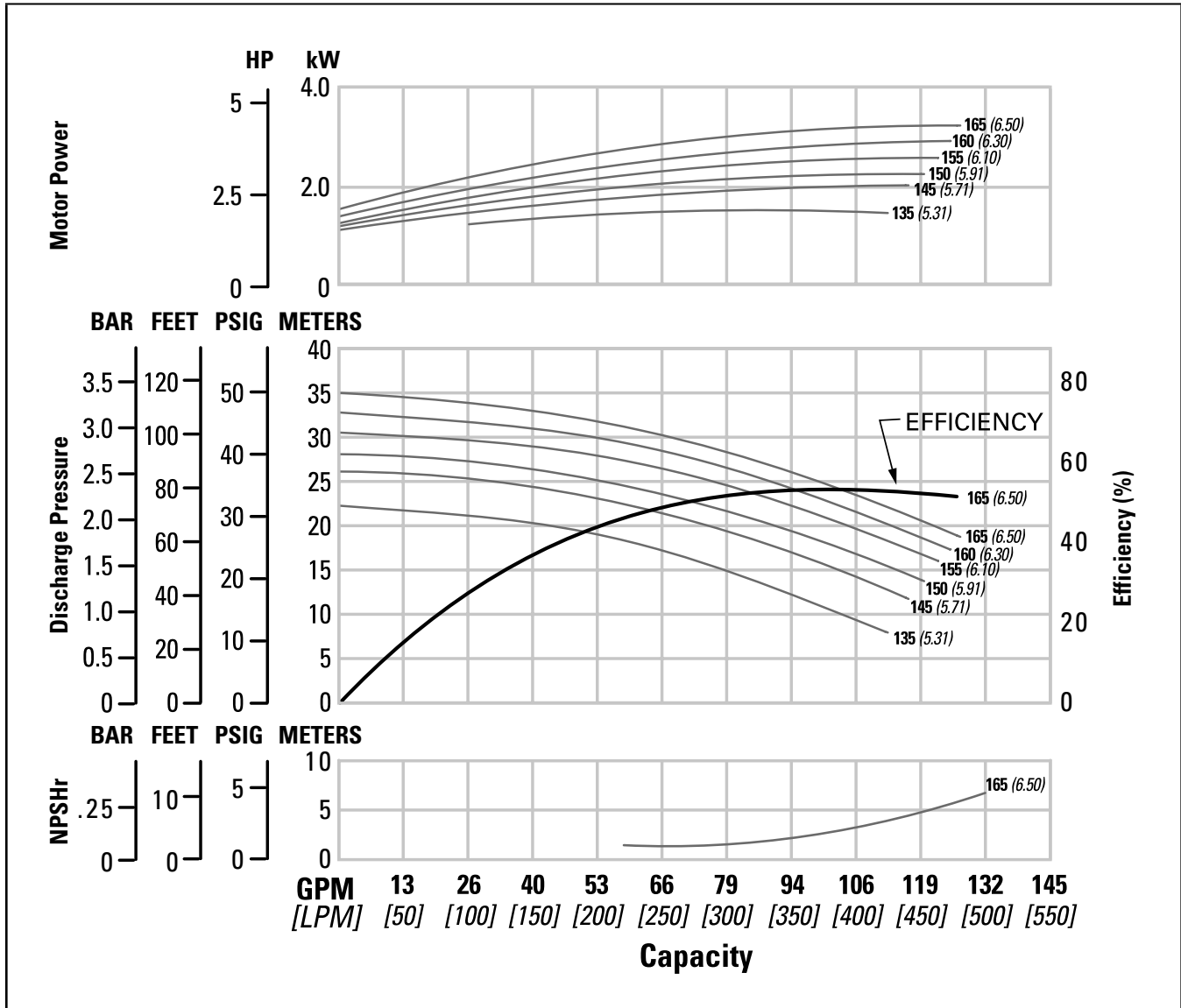

Height 323 mm (12.7")
 Width 337 mm (13.3")
 Length 627 mm (24.7")
 Ship Weight
 GFR-PP 53 kg (117 lbs)
 CFR-ETFE 54 kg (119 lbs)
 Fluid Inlet 51 mm (2")
 Fluid Discharge 38 mm (1-1/2")
 Rated Point 250 lpm (66.0 gpm)
 2.96 bar (43.0 psig)

All curves based upon pumping water at sea level, specific gravity 1.0, ambient temperature 20°C (68°F).

NOTE: Numbers shown to far right of all performance lines denote the diameter of the pump impeller in [millimeters (inches)]. Consult factory for availability of impeller trim sizes other than shown.

PERFORMANCE

3.7 kW (5 HP) - 60 Hz [TM6N] - 3600 RPM

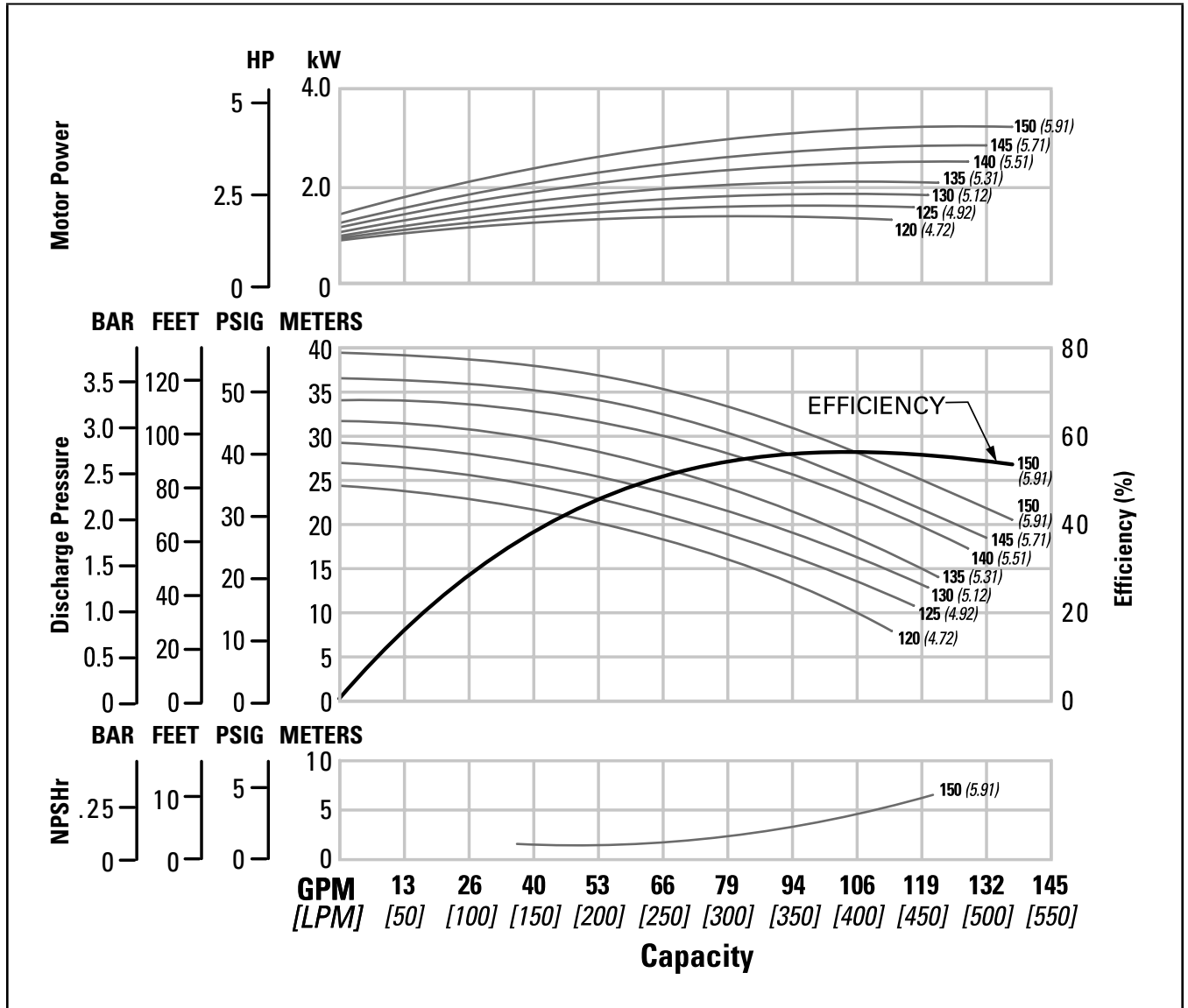

Height 323 mm (12.7")
 Width 337 mm (13.3")
 Length 627 mm (24.7")
 Ship Weight
 GFR-PP 53 kg (117 lbs)
 CFR-ETFE 54 kg (119 lbs)
 Fluid Inlet 51 mm (2")
 Fluid Discharge 38 mm (1-1/2")
 Rated Point 250 lpm (66.0 gpm)
 3.47 bar (50.4 psig)

All curves based upon pumping water at sea level, specific gravity 1.0, ambient temperature 20°C (68°F).

NOTE: Numbers shown to far right of all performance lines denote the diameter of the pump impeller [millimeters (inches)]. Consult factory for availability of impeller trim sizes other than shown.

3.7 kW (5 HP) - 50 Hz, Oversize Inlet (H) [TM10N] - 2900 RPM

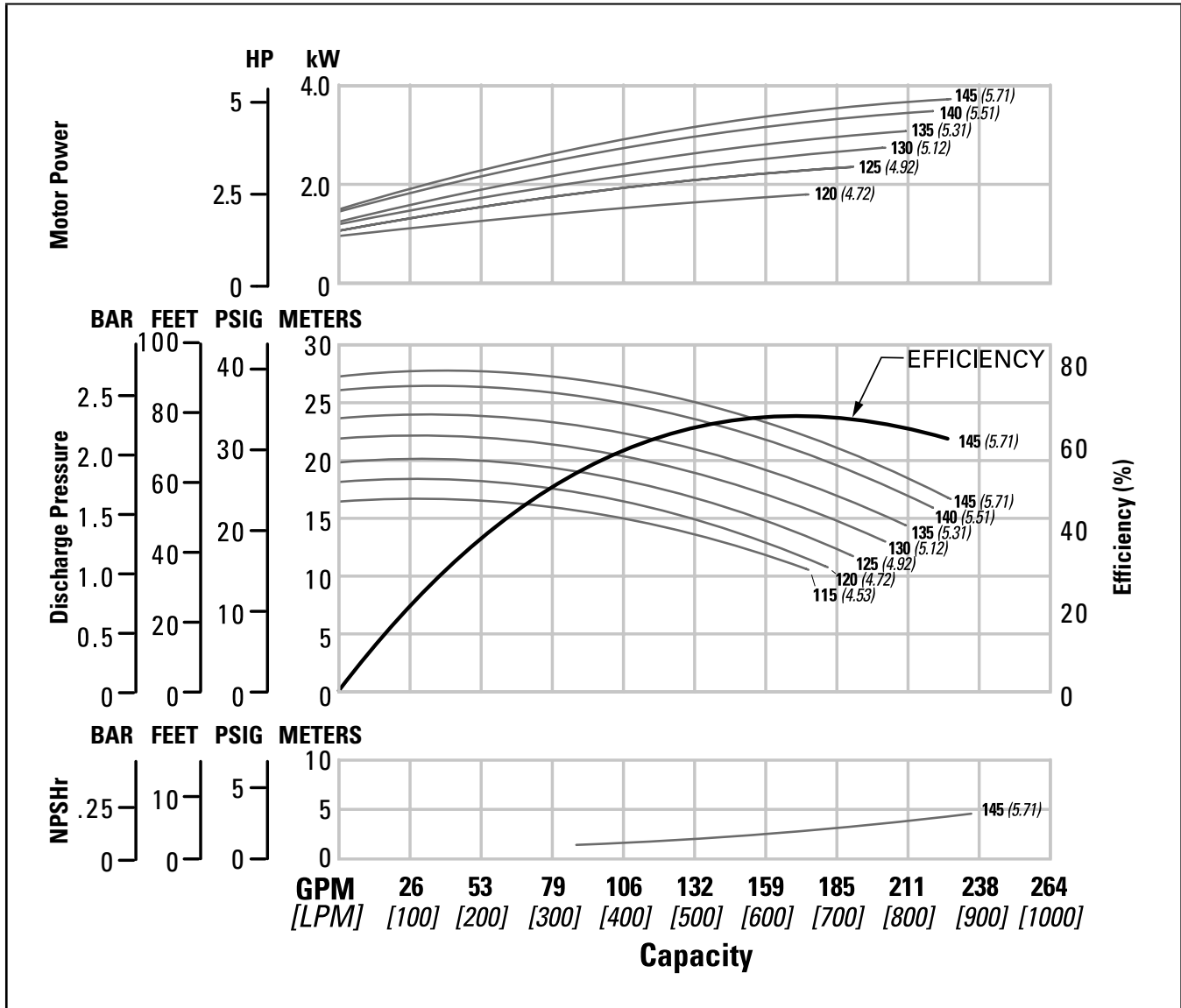

Height 333 mm (13.1")
 Width 347 mm (13.7")
 Length 636 mm (25.0")
 Ship Weight
 GFR-PP 53 kg (117 lbs)
 CFR-ETFE 54 kg (119 lbs)
 Fluid Inlet 64 mm (2-1/2")
 Fluid Discharge 51 mm (2")
 Rated Point 500 lpm (132 gpm)
 2.49 bar (36.1 psig)

All curves based upon pumping water at sea level, specific gravity 1.0, ambient temperature 20°C (68°F).

NOTE: Numbers shown to far right of all performance lines denote the diameter of the pump impeller in [millimeters (inches)]. Consult factory for availability of impeller trim sizes other than shown.

PERFORMANCE

3.7 kW (5 Hp) - 60 Hz, Oversize Inlet (H) [TM10N] - 3600 RPM

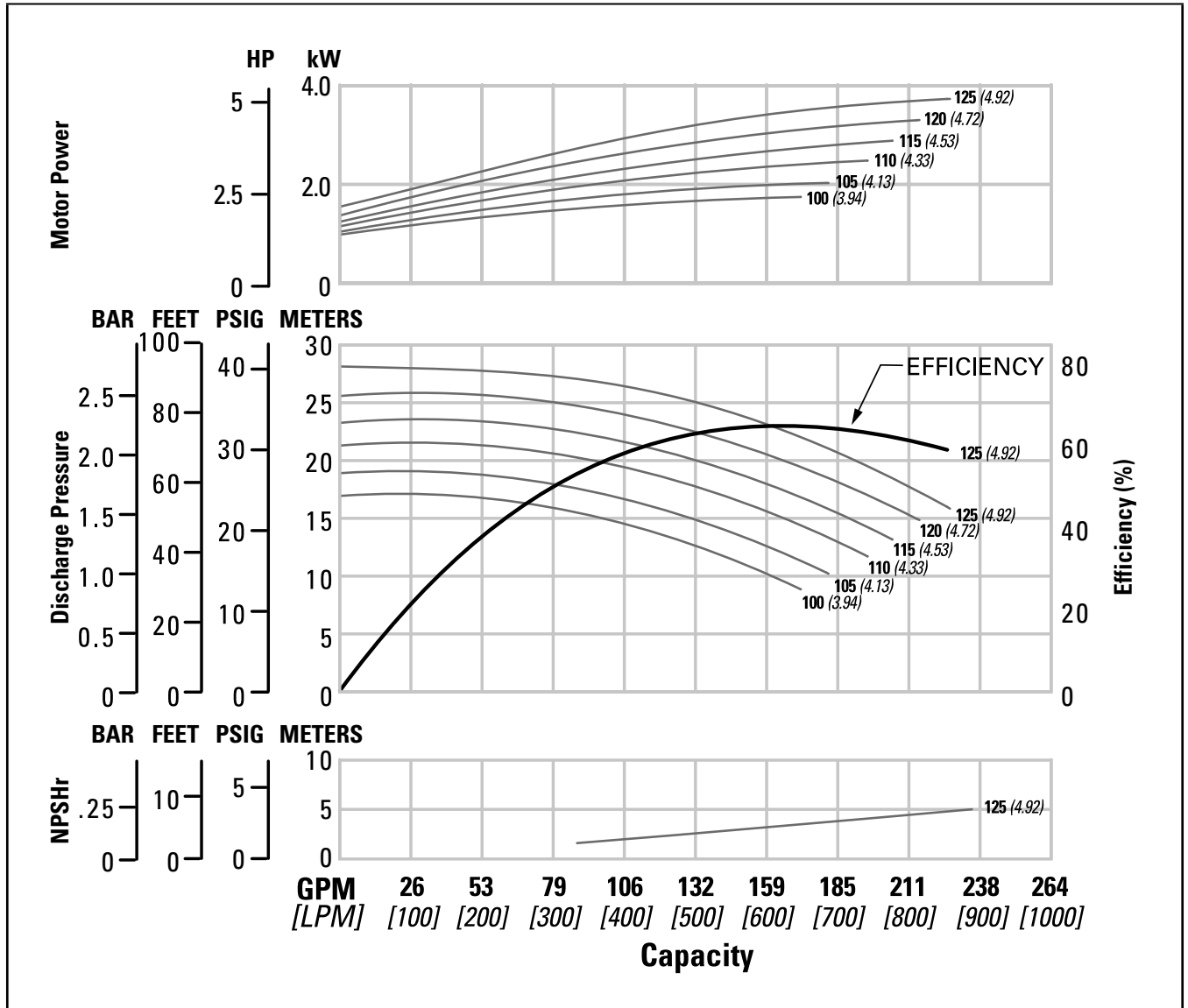

Height 333 mm (13.1")
 Width 347 mm (13.7")
 Length 636 mm (25.0")
 Ship Weight
 GFR-PP 53 kg (117 lbs)
 CFR-ETFE 54 kg (119 lbs)
 Fluid Inlet 64 mm (2-1/2")
 Fluid Discharge 51 mm (2")
 Rated Point 500 lpm (132 gpm)
 2.47 bar (35.8 psig)

All curves based upon pumping water at sea level, specific gravity 1.0, ambient temperature 20°C (68°F).

NOTE: Numbers shown to far right of all performance lines denote the diameter of the pump impeller [millimeters (inches)]. Consult factory for availability of impeller trim sizes other than shown.

SUGGESTED INSTALLATION

Wilden pumps are designed to meet the performance requirements of even the most demanding pumping applications. They have been designed and manufactured to the highest standards and are available in a variety of liquid path materials to meet your chemical resistance needs. Refer to the performance section of this manual for an in-depth analysis of the performance characteristics of your pump. The suction pipe size should be at least the equivalent or larger than the diameter size of the suction inlet on your Wilden pump. The suction hose/pipe must be non-collapsible. Discharge piping should also be the equivalent or larger than the diameter of the pump discharge which will help reduce friction losses. It is critical that all fittings and connections are airtight to reduce the risk of cavitation which may damage the pump.

INSTALLATION: Months of careful planning, study, and selection efforts can result in unsatisfactory pump performance if installation details are left to chance. Premature failure and long term dissatisfaction can be avoided if reasonable care is exercised throughout the installation process.

LOCATION: Noise, safety, and other logistical factors usually dictate where equipment will be situated on the production floor. Multiple installations with conflicting requirements can result in congestion of utility areas, leaving few choices for additional pumps. Within the framework of these and other existing conditions, every pump should be located in such a way that the 8 key factors are balanced against each other to maximum advantage.

ACCESS: First of all, the location should be accessible. If it's easy to reach the pump, maintenance personnel will have an easier time carrying out routine inspections and adjustments. Should major repairs become necessary, ease of access can play a key role in speeding the repair process and reducing total downtime.

ELECTRICAL SUPPLY: Every pump location should have all power lines, conduit and switches mounted in such a way as to avoid any risk or hazard to the user or work area. Keep in mind that while pumping some fluids it is required to ground the pump to prevent discharge of any static buildup. For best results, ensure a licensed professional performs any necessary installation work.

PUMP INLET: To optimize pump life it is important to install the pump in a position that will ensure a constant supply of process fluid. Running the unit dry will cause cavitation which could result in unnecessary vibration. This vibration can result in internal component damage that could diminish the life of the pump. Also, although the pump is designed to run dry without damage in the carbon / ceramic configuration, running dry on a regular basis can shorten the overall mean time between failure (MTBF) of the pump.

CONTROLS: All pumps should be outfitted with the appropriate safety shut off and controls to meet the local, state or federal requirements for the application in the area the pump is being used. To better understand the performance of the pump it is recommended that gauges be placed on the inlet and discharge lines of the pump, isolation gauges be installed for isolation and repairs and a flow meter be used to monitor the pump's performance over time.

PUMP DISCHARGE: Be sure that the discharge capabilities of the pump meet the required pressure to overcome the friction loss across the discharge piping, filters and valving. Do not close the downstream isolation valve of the pump while in operation. Doing so will cause the pump head to overheat and may damage the internals of the pump.

PIPING: Final determination of the pump site should not be made until the piping challenges of each possible location have been evaluated. The impact of current and future installations should be considered ahead of time to make sure that inadvertent restrictions are not created for any remaining sites.

The best choice possible will be a site involving the shortest and straightest hook-up of suction and discharge piping. Unnecessary elbows, bends, and fittings should be avoided. Pipe sizes and type should be selected to keep friction losses within practical limits. All piping should be supported independently of the pump. In addition, the piping should be aligned to avoid placing stress on the pump fittings.

Flexible hose can be installed to aid in absorbing the forces created by the natural vibration of the pump. If the pump is to be bolted down to a solid location, a mounting pad placed between the pump and the foundation will assist in minimizing pump vibration.

When pumps are installed in applications involving flooded suction or suction head pressures, a gate valve should be installed in the suction line to permit closing of the line for pump service.

SUBMERSIBLE APPLICATIONS: Wilden pumps can not be submerged for use. For applications where a submerged pump is required, please contact Wilden for an air-operated double-diaphragm pump.

WILDEN PUMPS ARE CAPABLE OF PASSING SOLIDS BELOW 5μ (microns), ALTHOUGH ANY SOLIDS WITHIN THE PROCESS STREAM OF A WILDEN PUMP COULD WEAR CRITICAL COMPONENTS.

This wear will diminish performance or cause failure of the pump. Standard carbon fitted Wilden Mag-Drive pumps are suited for limited dry run conditions only. Other materials such as Rulon® and SSIC fitted pumps are not suitable for dry run conditions.

This illustration is a generic representation of a Wilden pump installation.

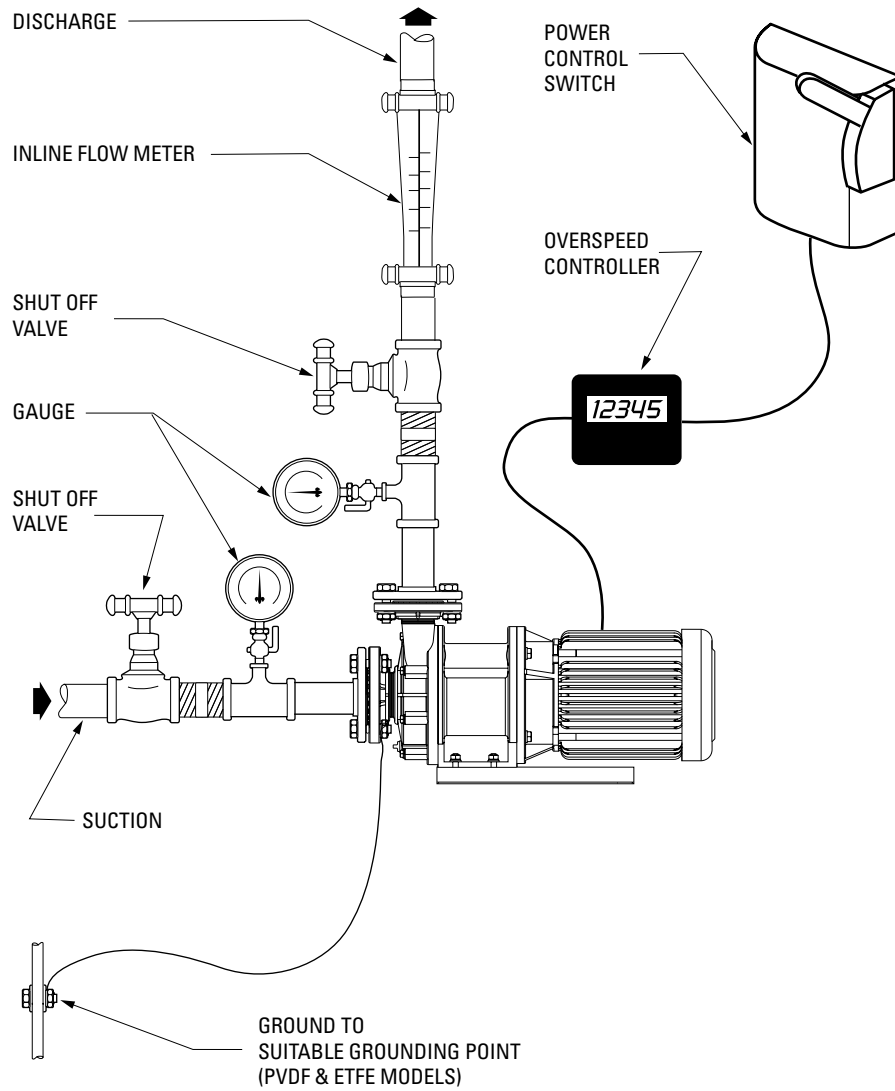

SUGGESTED OPERATION & MAINTENANCE

OPERATION: Pump discharge rate can be controlled by modifying the pump impeller, changing to a different motor power rating or through a “turndown” of the motor RPMs. Pump discharge rate can also be controlled by throttling the pump discharge by partially closing a valve in the discharge line of the pump. Do not close the discharge valve all the way as this may cause a heat buildup in the liquid end of the pump and damage the pump internals.

MAINTENANCE AND INSPECTIONS: Since each application is unique, maintenance schedules may be different for every pump. Frequency of use, line pressure, viscosity and abrasiveness of process fluid all affect the parts life

of a Wilden pump. Periodic inspections have been found to offer the best means for preventing unscheduled pump downtime. Personnel familiar with the pump’s construction and service should be informed of any abnormalities that are detected during operation.

RECORDS: When service is required, a record should be made of all necessary repairs and replacements. Over a period of time, such records can become a valuable tool for predicting and preventing future maintenance problems and unscheduled downtime. In addition, accurate records make it possible to identify pumps that are poorly suited to their applications.

TROUBLESHOOTING

Motor will not rotate when system is turned on.

1. Ensure that motor is connected to power supply and that supply switch is installed properly.
2. Inspect motor to ensure that it is in operating condition and does not require service.
3. Ensure that the power lines have been properly connected for the supply voltage and Hz.
4. Ensure that no debris is lodged within the motor assembly.

Motor is turning but no fluid is moving.

1. Check to make sure that all fluid port plugs were removed before connection to the system.
2. Check alignment of the outer magnet to the inner magnet to ensure proper engagement.
3. Check positioning of the pump with regard to the source fluid. Check to make sure that the pump is capable of drawing in process fluid and readjust pump placement if necessary.
4. Check to make sure that inlet and outlet isolation and system valves are in the full open position.
5. Confirm that the pump impeller has been trimmed to the proper diameter for the viscosity and specific gravity of the fluid being pumped.
6. Ensure that no debris has been lodged in the pump impeller.
7. Inspect the shaft, bushing and impeller for damage and alignment.
8. Inspect the pump rotation to insure the pump has been wired correctly.
9. Recheck the process fluid characteristics for viscosity, specific gravity, temperature and solids. Check that pump has not de-coupled due to high specific gravity or viscosity.

Process fluid is leaking from the pump head.

1. Immediately turn off the pump.
2. Inspect the pump housing, o-rings, flanges and impeller housing for damage or wear. Replace as necessary.
3. Confirm the fasteners have been torqued to the correct specifications.

4. Confirm that the process fluid is compatible with the pump liquid end components and make changes as necessary.

Flow rate is ABOVE the specified flow for the application.

1. Confirm the system total dynamic head conditions have not changed from the specified values.
2. Confirm the process fluid is the same temperature, viscosity and specific gravity as the system specified.
3. Confirm that the pump impeller has been trimmed to the proper dimension as required for the application.
4. Confirm that the pump horsepower meets the system conditions.
5. Confirm that the Hz rating for the motor is correct (50 Hz will turn at a slower RPM than 60 Hz)
6. Confirm that the system valves have been positioned correctly for desired flow conditions.

Flow rate is BELOW the specified flow for the application.

1. Confirm the system total dynamic head conditions have not changed from the specified values.
2. Confirm the process fluid is the same temperature, viscosity and specific gravity as the system specified.
3. Confirm that the pump impeller has been trimmed to the proper dimension as required for the application.
4. Confirm that the pump horsepower meets the system conditions.
5. Confirm that the Hz rating for the motor is correct (50 Hz will turn at a slower RPM than 60 Hz)
6. Confirm that the system valves have been positioned correctly for desired flow conditions.

The pump continually cavitates, causing vibration and/or pump damage.

1. Inspect the inlet line to ensure it fits within the NPSH requirements for the specified operating conditions.
2. Confirm that the process fluid viscosity matches the process specifications.
3. Ensure that the pump impeller has been trimmed to the correct diameter for the process specifications.

Tools Required:

- Metric open-end wrench set
- Adjustable wrench
- Strap wrench or soft jaw vise
- Medium flat head screwdriver
- Metric hex wrench set

CAUTION: Before any service is performed on a Wilden pump, all electrical lines must be disconnected and all process fluid drained from the pump. DO NOT open the pump connections if process fluid pressure remains inside the pump. Use the liquid end drain plug to drain remaining fluid from the impeller chamber.

NOTE: The model shown in this example represents all five sizes of Wilden mag-drive pumps.

**Step 1**

Before disassembly, mark motor, mounting bracket and pump head to ensure proper configuration during reassembly.

**Step 2**

Using a metric wrench, remove all liquid end bolts from pump head.

**Step 3**

Carefully remove the outer liquid casing from the central mounting bracket. Do not twist or rock the liquid end to assist with removal. This will place unnecessary torque on the shaft and may damage it.



Step 4

Remove and inspect outer casing o-ring for damage or wear. Replace as necessary.



Step 5

Carefully remove the impeller/magnet assembly. Use caution not to pinch fingers as the impeller will show resistance being removed due to the magnetic field of the outer magnet.



Step 6

Remove the rear casing of the liquid end from the mounting bracket. Inspect for wear inside or out, as this may be a sign of misalignment of the impeller or outer magnet.

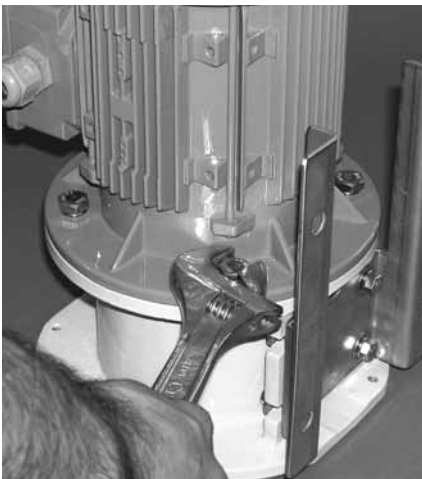

Step 7

Remove the bolts holding the mounting bracket to the motor. Use caution when removing as the motor is heavy and may tip causing injury.



Step 8

Carefully remove the mounting bracket from the motor, exposing the outer magnet.

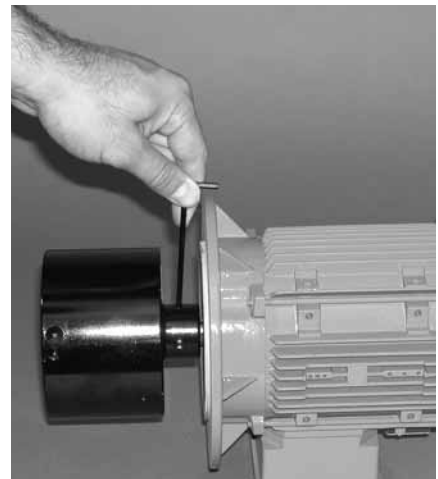

Step 9

If it is necessary to remove the outer magnet from the motor, use a hex wrench to remove the two (2) set screws from the shaft end. **NOTE:** The outer magnet adjustment screws on some Wilden Mag-Drive pumps must be accessed through the adjustment port located under the mounting bracket.

T-Mag™ **PUMP DISASSEMBLY**

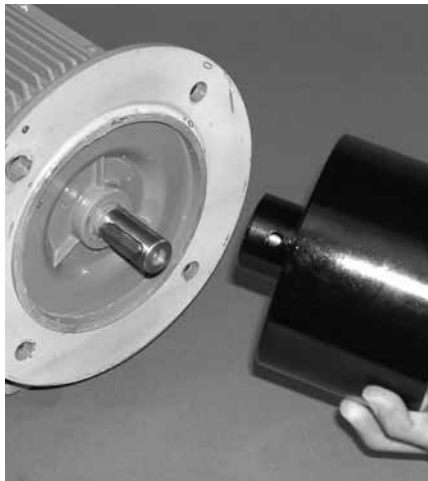

Step 10

Once the set screws are removed, inspect the shaft keyway and bell housing for wear or damage and replace as necessary.



Step 11

Carefully remove the pump shaft from the front shaft support. **DO NOT** twist or flex the shaft to assist removal. Pull vertically to free the shaft from the front support.



Step 12

Gently lift up on the front buffer to free it from the inlet port. **DO NOT** use any tools for removal as this may damage the part forcing replacement.



Step 13

Gently lift up on the front shaft support to free it from the pump inlet port. **DO NOT** use any tools as this may damage the part forcing replacement.



Step 14

If the inlet or discharge flanges are worn or damaged, remove and replace the flange and o-ring. Use a strap wrench or soft jawed vise for removal of the old flange and installation of the new one.

REASSEMBLY HINTS & TIPS

Tools Required:

- Metric open-end wrench set
- Adjustable wrench
- Strap wrench or soft jaw vise
- Medium flat head screwdriver
- Metric hex wrench set

CAUTION: Before reassembling a Wilden pump, carefully read the following instructions and special procedures. Failure to do so may result in premature failure of the pump components or damage to an individual part making assembly impossible.

NOTE: The steps shown in this example represents all five sizes of Wilden mag-drive pumps. The steps shown are not necessarily in order of reassembly of the pump.



Tip 1

When installing the shaft into the front shaft support, ensure that the trimmed end of the shaft fits cleanly into the support. Gently inset shaft by hand or using a hand press. Always use a towel or rag to protect the shaft.

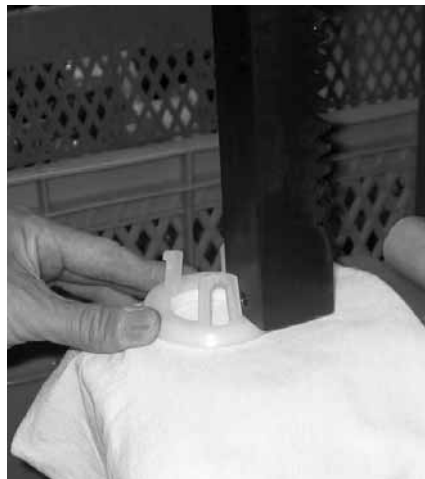

Tip 2

When installing the front wear ring into the front buffer use a hand press to ensure that the wear ring is evenly inserted. Failure to ensure a level wear surface will damage the impeller wear ring and reduce the life of the pump.



Tip 3

Before installing the flanges and o-rings on the inlet and discharge ports, spray the o-rings with a lubricant to ease installation. Confirm lubricant used is compatible with all pump materials and process application.

**Tip 4**

When completing the final tightening rotations on the flanges, use a strap wrench or a soft jawed vise to prevent damage to the flanges.

**Tip 5**

Use a hand press to carefully insert the shaft and front shaft support into the front casing.

**Tip 6**

Align the assembled front buffer assembly into the front casing by carefully aligning the "feet" of the buffer with the three "fins" of the casing. This will prevent rotation or misalignment of the buffer during operation.

**Tip 7**

Before installing the impeller/magnet assembly, use an adhesive tape to remove ALL metal fragments or debris that may be on the outside of the magnet housing. Failure to do so will result in premature wear of the rear casing of the pump.

**Tip 8**

Complete the assembly of the wet end of the pump by placing the rear casing with o-ring installed.

**Tip 9**

When installing the outer magnet onto the motor shaft, use a wood block or plastic buffer to prevent damage to the magnets. Never use a hammer directly on the magnet assembly.



Tip 10

For proper alignment of the magnetic field, align the end of the shaft flush with the inside bottom of the magnet assembly.



Tip 11

Before installation of the previously assembled liquid casing of the pump, use an adhesive tape to remove ALL metal fragments or debris that may be on the outside of the magnet housing. Failure to do so will result in premature wear of the rear casing of the pump.

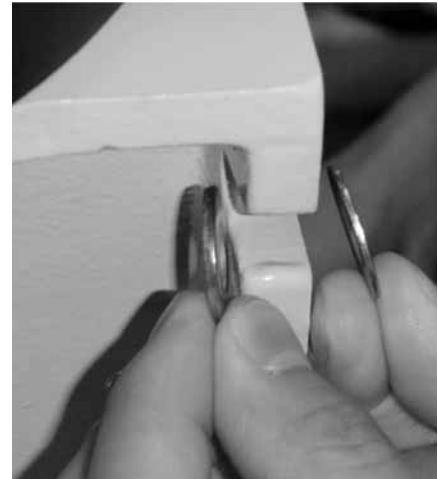

Tip 12

When installing the foot plate to the mounting bracket of the pump, be sure to use one washer between the base and the bracket and one between the nut and the top of the bracket.

Torque Specs for Reassembly - N•m (in-lbs)

Model Size	1/2 HP	1 HP	2 HP	3 HP	5 HP
Outer casing bolts	2.9 (26.0)	2.9 (26.0)	2.9 (26.0)	2.9 (26.0)	2.9 (26.0)
Drain Plug	-	2.0 (17.3)	2.0 (17.3)	2.0 (17.3)	2.0 (17.3)
Bracket to Motor	7.9 (69.5)	7.9 (69.5)	7.9 (69.5)	7.9 (69.5)	7.9 (69.5)
Bracket to Base	7.9 (69.5)	7.9 (69.5)	7.9 (69.5)	7.9 (69.5)	7.9 (69.5)

NOTE: Additional assistance for the maintenance, repair or assembly of a Wilden pump is available from the factory. If you have any additional questions regarding service or repair, contact Wilden in the U.S. at (909) 422-1730.

Max Impeller Diameter Chart

Model Size	POWER		Max Impellar Diameter (mm)	
	Kw	Hp	50HZ	60HZ
TM4H	0.4	1/2	102	90
TM4K	0.75	1	125	108
TM6L	1.5	2	142	123
TM6M	2.2	3	156	135
TM6N	3.7	5	165	150
TM10N	3.7	5	145	125

NOTES

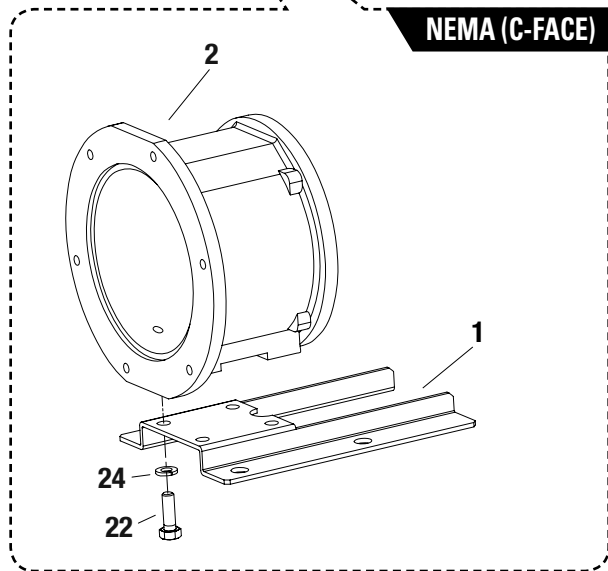
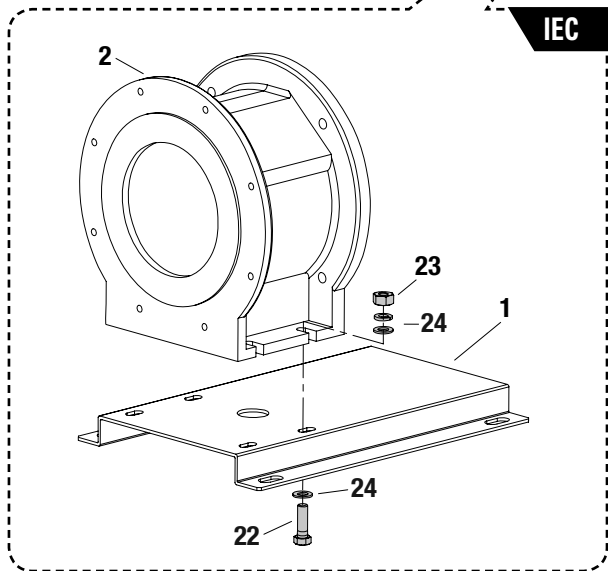
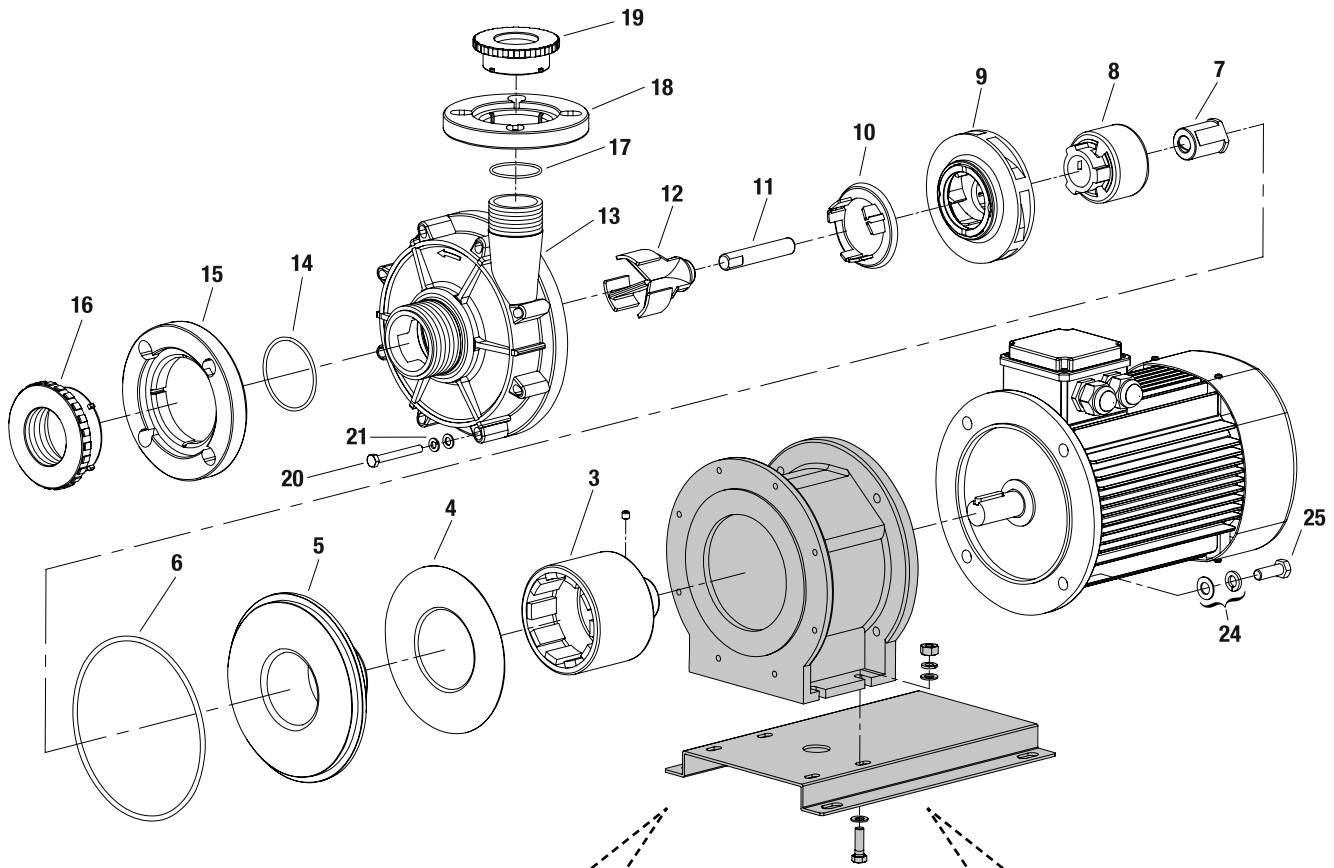

EXPLODED VIEW & PARTS LISTING

POLYPROPYLENE

Glass-Fiber Reinforced

PARTS LISTING

No	Part Description	Qty.	1/2 HP	1 HP	2 HP	3 HP	5 HP	5 HP (2-1/2" inlet)
1	Base (SUS304)	1	TM-X0B11S	TM-X1B11S	TM-X3B11S	TM-X3B11S	TM-X5B11S	TM-X5B11S
2	Bracket-IEC	1	TM-X0B21F-ZI	TM-X1B21F-ZI	TM-X3B21F-ZI	TM-X3B21F-ZI	TM-X5B21F-ZI	TM-X5B21F-ZI
3	Outer magnet-IEC	1	TM-X0M01-I	TM-X1M01-I	TM-X2M01-I	TM-X3M01-I	TM-X5M01-I	TM-X5M01-I
	Outer magnet-NEMA		TM-X0M01-N	TM-X1M01-N	TM-X2M01-N	TM-X3M01-N	TM-X5M01-N	TM-X5M01-N
4	Rear casing mount (SUS304)	1	N/A	TM-X1R21	TM-X5R21	TM-X5R21	TM-X5R21	TM-X5R21
5	Rear casing assembly (PP+GF/A)	1	TM-X0R01GA-Z	TM-X1R01GA-Z	TM-X5R01GA-Z	TM-X5R01GA-Z	TM-X5R01GA-Z	TM-X5R01GA-Z
6	O-ring (F. Casing, viton)	1	TM-RG356V	TM-RG362V	TM-RG368V	TM-RG368V	TM-RG368V	TM-RG368V
7	Bearing (HD Carbon)	1	TM-X1S21C	TM-X1S21C	TM-X5S21C	TM-X5S21C	TM-X5S21C	TM-X5S21C
	Bearing (Rulon)		TM-X1S21R	TM-X1S21R	TM-X5S21R	TM-X5S21R	TM-X5S21R	TM-X5S21R
	Bearing (SSiC)		TM-X1S21S	TM-X1S21S	TM-X5S21S	TM-X5S21S	TM-X5S21S	TM-X5S21S
8	Inner magnet (PP)	1	TM-X0L23P-Z	TM-X1L23P-Z	TM-X2L23P-Z	TM-X3L23P-Z	TM-X5L23P-Z	TM-X5L23P-Z
9	Impeller wear ring assy. (PPG/C)	1	TM-X0L05GC	TM-X1L05GC	TM-X2L05GC	TM-X3L05GC	TM-XHL05GC	TM-X5L05GC
	Impeller wear ring assy. (PPG/R)		TM-X0L05GR	TM-X1L05GR	TM-X2L05GR	TM-X3L05GR	TM-XHL05GR	TM-X5L05GR
	Impeller wear ring assy. (PPG/S)		TM-X0L05GS	TM-X1L05GS	TM-X2L05GS	TM-X3L05GS	TM-XHL05GS	TM-X5L05GS
10	Thrust ring buffer assy.(ETFE/A)	1	TM-X0S40EA	TM-X0S40EA	TM-X3S40EA	TM-X3S40EA	TM-X3S40EA	TM-X5S40EA
	Thrust ring buffer assy. (ETFE/Ssic)		TM-X0S40ES	TM-X0S40ES	TM-X3S40ES	TM-X3S40ES	TM-X3S40ES	TM-X5S40EA
11	Shaft (995 Ceramic)	1	TM-X1S11A	TM-X1S11A	TM-X5S11A	TM-X5S11A	TM-X5S11A	TM-X5S11A
	Shaft (SSiC)		TM-X1S11S	TM-X1S11S	TM-X5S11S	TM-X5S11S	TM-X5S11S	TM-X5S11S
12	Front shaft support	1	TM-X1F15EN-Z	TM-X1F15EN-Z	TM-X3F15EN-Z	TM-X3F15EN-Z	TM-X3F15EN-Z	TM-X5F15EN-Z
13	Front casing (PP)-BSPT	1	TM-X0F11G-ZB	TM-X1F11G-ZB	TM-X3F11G-ZB	TM-X3F11G-ZB	TM-XHF11G-ZB	TM-X5F11G-ZB
	Front casing (PP)-NPT		TM-X0F11G-ZN	TM-X1F11G-ZN	TM-X3F11G-ZN	TM-X3F11G-ZN	TM-XHF11G-ZN	TM-X5F11G-ZN
14	O-ring (Inlet flange, viton)	1	TM-RG129V	TM-RG129V	TM-RG137V	TM-RG137V	TM-RG137V	TM-RG134V
15	Inlet flange (PP)	1	TM-X1F21G-Z	TM-X1F21G-Z	TM-X3F21G-Z	TM-X3F21G-Z	TM-X3F21G-Z	TM-X5F21G-Z
16	Inlet flange adaptor (PP)-BSPT	1	TM-X1F24G-ZB	TM-X1F24G-ZB	TM-X3F24G-ZB	TM-X3F24G-ZB	TM-X3F24G-ZB	TM-X5F24G-ZB
	Inlet flange adaptor (PP)-NPT		TM-X1F24G-ZN	TM-X1F24G-ZN	TM-X3F24G-ZN	TM-X3F24G-ZN	TM-X3F24G-ZN	TM-X5F24G-ZN
17	O-ring (Outlet flange, viton)	1	TM-RG129V	TM-RG129V	TM-RG129V	TM-RG129V	TM-RG129V	TM-RG137V
18	Outlet flange (PP)	1	TM-X1F21G-Z	TM-X1F21G-Z	TM-X1F21G-Z	TM-X1F21G-Z	TM-X1F21G-Z	TM-X3F21G-Z
19	Outlet flange adaptor (PP)-BSPT	1	TM-X1F31G-ZB	TM-X1F31G-ZB	TM-X3F31G-ZB	TM-X3F31G-ZB	TM-X3F31G-ZB	TM-X3F24G-ZB
	Outlet flange adaptor (PP)-NPT		TM-X1F31G-ZN	TM-X1F31G-ZN	TM-X3F31G-ZN	TM-X3F31G-ZN	TM-X3F31G-ZN	TM-X3F24G-ZN
20	Bolt, Hex Head, M8 (Liquid Casing)	8	N/A	TM99-6040-03	TM99-6041-03	TM99-6041-03	TM99-6041-03	TM99-6042-03
	Bolt, Hex Head, M8 (Liquid Casing - 1/2HP)	6	TM99-6043-03	N/A	N/A	N/A	N/A	N/A
	Bolt, Hex Head, M8 (Liquid Casing - 1/2HP)	6	TM99-6044-03	N/A	N/A	N/A	N/A	N/A
21	Washer, Flat (Liquid Casing)	8	TM99-6700-03	TM99-6700-03	TM99-6700-03	TM99-6700-03	TM99-6700-03	TM99-6700-03
22	Bolt, Hex Head (Base)	4	TM99-6055-03	TM99-6055-03	TM99-6056-03	TM99-6056-03	TM99-6056-03	TM99-6056-03
23	Nut, Hex (Base)	4	TM99-6400-03	TM99-6400-03	TM99-6401-03	TM99-6401-03	TM99-6401-03	TM99-6401-03
24	Washer, Flat (Base)	4	TM99-6700-03	TM99-6700-03	TM99-6701-03	TM99-6701-03	TM99-6701-03	TM99-6701-03
25	Bolt, Hex Head, 10 x 25 mm (IEC)	4	N/A	TM99-6050-03	TM99-6050-03	TM99-6050-03	TM99-6050-03	TM99-6050-03
	Bolt, Hex Head, 16 x 3/8" (C-Face)	4	N/A	TM99-6052-03	TM99-6052-03	TM99-6052-03	TM99-6053-03	TM99-6053-03
	Bolt, Hex Head, 16 x 5/16" (IEC - 1/2HP)	4	TM99-6054-03	N/A	N/A	N/A	N/A	N/A
	Bolt, Hex Head, 16 x 3/8" (C-Face - 1/2HP)	4	TM99-6057-03	N/A	N/A	N/A	N/A	N/A

NOTE: Impeller diameter is specific to each model and is noted above by "XXX" in the effected part number.
The "XXX" changes to the exact millimeter trim when ordered.

EXPLODED VIEW & PARTS LISTING

ETFE

Carbon-Fiber Reinforced

EXPLODED VIEW

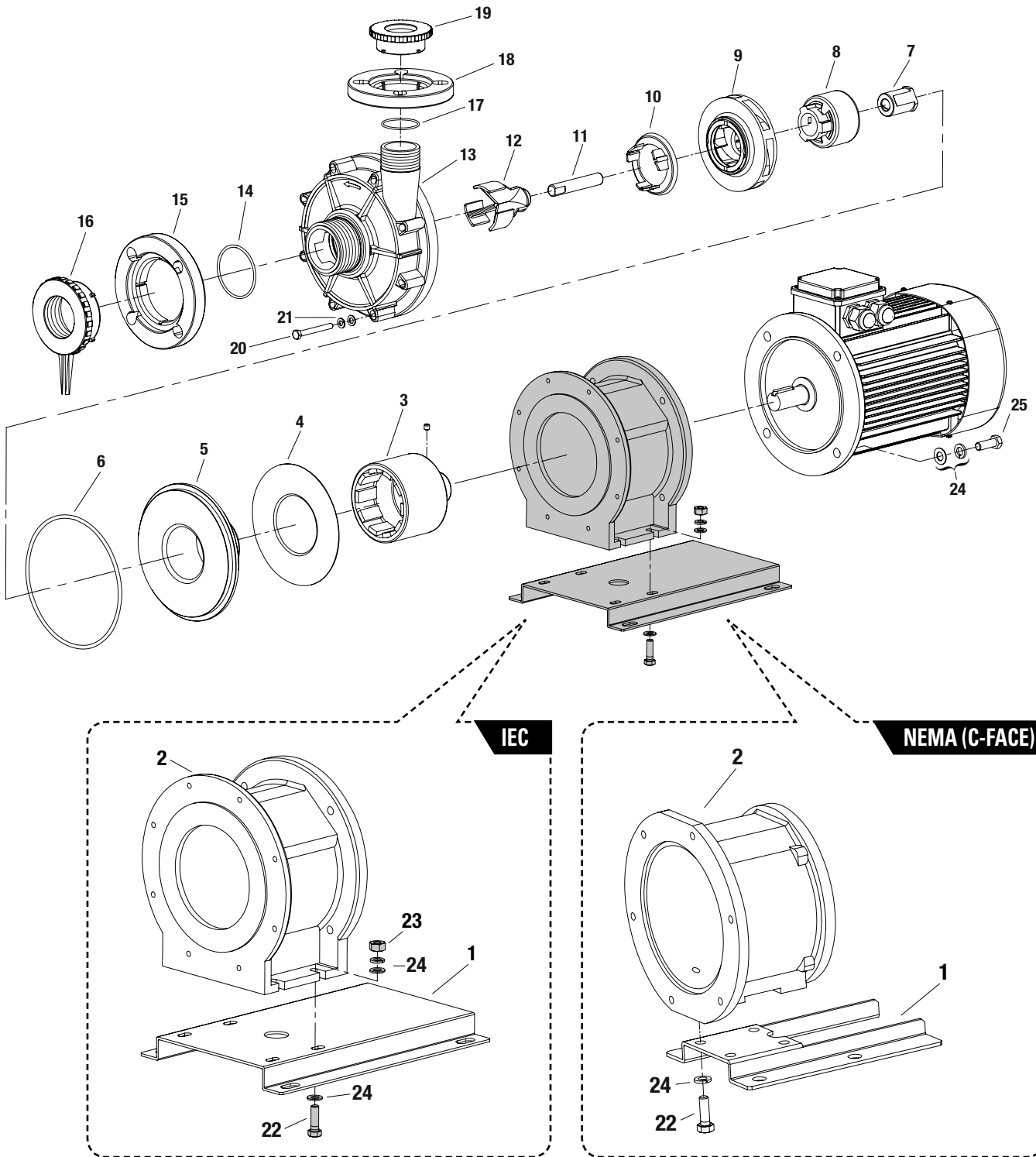

EXPLODED VIEW & PARTS LISTING

ETFE

Glass-Fiber Reinforced

PARTS LISTING

No	Part Description	Qty.	1/2 HP	1 HP	2 HP	3 HP	5 HP	5 HP (2-1/2" inlet)
1	Base (SUS304)	1	TM-X0B11S	TM-X1B11S	TM-X3B11S	TM-X3B11S	TM-X5B11S	TM-X5B11S
2	Bracket-IE ^c	1	TM-X0B21F-ZI	TM-X1B21F-ZI	TM-X3B21F-ZI	TM-X3B21F-ZI	TM-X5B21F-ZI	TM-X5B21F-ZI
3	Outer magnet-IEC	1	TM-X0M01-I	TM-X1M01-I	TM-X2M01-I	TM-X3M01-I	TM-X5M01-I	TM-X5M01-I
	Outer magnet-NEMA		TM-X0M01-N	TM-X1M01-N	TM-X2M01-N	TM-X3M01-N	TM-X5M01-N	TM-X5M01-N
4	Rear casing mount (SUS304)	1	N/A	TM-X1R21	TM-X5R21	TM-X5R21	TM-X5R21	TM-X5R21
5	Rear casing assembly (ETFE+CF/A)	1	TM-X0R01EA-Z	TM-X1R01EAN-Z	TM-X5R01EAN-Z	TM-X5R01EAN-Z	TM-X5R01EAN-Z	TM-X5R01EAN-Z
	Rear casing assembly (ETFE+CF/S)	1	N/A	TM-X1R01ESPN-Z	TM-X5R01ESPN-Z	TM-X5R01ESPN-Z	TM-X5R01ESPN-Z	TM-X5R01ESPN-Z
6	O-ring (F. Casing, viton)	1	TM-RG129V	TM-RG362V	TM-RG368V	TM-RG368V	TM-RG368V	TM-RG368V
7	Bearing (HD Carbon)		TM-X1S21C	TM-X1S21C	TM-X5S21C	TM-X5S21C	TM-X5S21C	TM-X5S21C
	Bearing (Rulon)		TM-X1S21R	TM-X1S21R	TM-X5S21R	TM-X5S21R	TM-X5S21R	TM-X5S21R
	Bearing (SSiC)	1	TM-X1S21S	TM-X1S21S	TM-X5S21S	TM-X5S21S	TM-X5S21S	TM-X5S21S
8	Inner magnet (PP)	1	TM-X0L23P-Z	TM-X1L23P-Z	TM-X2L23P-Z	TM-X3L23P-Z	TM-X5L23P-Z	TM-X5L23P-Z
	Inner magnet (ETFE)		TM-X0L23E-Z	TM-X1L23E-Z	TM-X2L23E-Z	TM-X3L23E-Z	TM-X5L23E-Z	TM-X5L23E-Z
9	Impeller wear ring assy. (ETFE/C)		TM-X0L05EC	TM-X1L05EC	TM-X2L05EC	TM-X3L05EC	TM-XHL05EC	TM-X5L05EC
	Impeller wear ring assy. (ETFE/R)	1	TM-X0L05ER	TM-X1L05ER	TM-X2L05ER	TM-X3L05ER	TM-XHL05ER	TM-X5L05ER
	Impeller wear ring assy. (ETFE/Ssic)		TM-X0L05ES	TM-X1L05ES	TM-X2L05ES	TM-X3L05ES	TM-XHL05ES	TM-X5L05ES
10	Thrust ring buffer assy.(ETFE/A)	1	TM-X0S40EA	TM-X0S40EA	TM-X3S40EA	TM-X3S40EA	TM-X3S40EA	TM-X5S40EA
	Thrust ring buffer assy. (ETFE/Ssic)		TM-X0S40ES	TM-X0S40ES	TM-X3S40ES	TM-X3S40ES	TM-X3S40ES	TM-X5S40EA
11	Shaft (995 Ceramic)	1	TM-X1S11A	TM-X1S11A	TM-X5S11A	TM-X5S11A	TM-X5S11A	TM-X5S11A
	Shaft (SSiC)	1	TM-X1S11S	TM-X1S11S	TM-X5S11S	TM-X5S11S	TM-X5S11S	TM-X5S11S
12	Front shaft support		TM-X1F15EN-Z	TM-X1F15EN-Z	TM-X3F15EN-Z	TM-X3F15EN-Z	TM-X3F15EN-Z	TM-X5F15EN-Z
13	Front casing (ETFE)-BSPT	1	TM-X0F11E-ZB	TM-X1F11E-ZB	TM-X3F11E-ZB	TM-X3F11E-ZB	TM-XHF11E-ZB	TM-X5F11E-ZB
	Front casing (ETFE)-NPT	1	TM-X0F11E-ZN	TM-X1F11E-ZN	TM-X3F11E-ZN	TM-X3F11E-ZN	TM-XHF11E-ZN	TM-X5F11E-ZN
14	O-ring (Inlet flange, viton)	1	TM-RG129V	TM-RG129V	TM-RG137V	TM-RG137V	TM-RG137V	TM-RG234V
15	Inlet flange (ETFE)		TM-X1F21EN-Z	TM-X1F21EN-Z	TM-X3F21EN-Z	TM-X3F21EN-Z	TM-X3F21EN-Z	TM-X5F21EN-Z
16	Inlet flange adaptor (ETFE)-BSPT	1	TM-X1F24EN-ZB	TM-X1F24EN-ZB	TM-X3F24EN-ZB	TM-X3F24EN-ZB	TM-X3F24EN-ZB	TM-X5F24EN-ZB
	Inlet flange adaptor (ETFE)-NPT	1	TM-X1F24EN-ZN	TM-X1F24EN-ZN	TM-X3F24EN-ZN	TM-X3F24EN-ZN	TM-X3F24EN-ZN	TM-X5F24EN-ZN
17	O-ring (Outlet flange, viton)	1	TM-RG129V	TM-RG129V	TM-RG129V	TM-RG129V	TM-RG129V	TM-RG137V
18	Outlet flange (ETFE)		TM-X1F21EN-Z	TM-X1F21EN-Z	TM-X1F21EN-Z	TM-X1F21EN-Z	TM-X1F21EN-Z	TM-X3F21EN-Z
19	Outlet flange adaptor (ETFE)-BSPT	8	TM-X1F31EN-ZB	TM-X1F31EN-ZB	TM-X3F31EN-ZB	TM-X3F31EN-ZB	TM-X3F31EN-ZB	TM-X3F24EN-ZB
	Outlet flange adaptor (ETFE)-NPT	6	TM-X1F31EN-ZN	TM-X1F31EN-ZN	TM-X3F31EN-ZN	TM-X3F31EN-ZN	TM-X3F31EN-ZN	TM-X3F24EN-ZN
20	Bolt, Hex Head, M8 (Liquid Casing)	6	N/A	TM99-6040-03	TM99-6041-03	TM99-6041-03	TM99-6041-03	TM99-6042-03
	Bolt, Hex Head, M8 (Liquid Casing - 1/2HP)	8	TM99-6043-03	N/A	N/A	N/A	N/A	N/A
	Bolt, Hex Head, M8 (Liquid Casing - 1/2HP)	4	TM99-6044-03	N/A	N/A	N/A	N/A	N/A
21	Washer, Flat (Liquid Casing)	4	TM99-6700-03	TM99-6700-03	TM99-6700-03	TM99-6700-03	TM99-6700-03	TM99-6700-03
22	Bolt, Hex Head (Base)	4	TM99-6055-03	TM99-6055-03	TM99-6056-03	TM99-6056-03	TM99-6056-03	TM99-6056-03
23	Nut, Hex (Base)	4	TM99-6400-03	TM99-6400-03	TM99-6401-03	TM99-6401-03	TM99-6401-03	TM99-6401-03
24	Washer, Flat (Base)	4	TM99-6700-03	TM99-6700-03	TM99-6701-03	TM99-6701-03	TM99-6701-03	TM99-6701-03
25	Bolt, Hex Head, 10 x 25 mm (IEC)	4	N/A	TM99-6050-03	TM99-6050-03	TM99-6050-03	TM99-6050-03	TM99-6050-03
	Bolt, Hex Head, 16 x 3/8" (C-Face)	4	N/A	TM99-6052-03	TM99-6052-03	TM99-6052-03	TM99-6053-03	TM99-6053-03
	Bolt, Hex Head, 16 x 5/16" (IEC - 1/2HP)	1	TM99-6054-03	N/A	N/A	N/A	N/A	N/A
	Bolt, Hex Head, 16 x 3/8" (C-Face - 1/2HP)		TM99-6057-03	N/A	N/A	N/A	N/A	N/A

NOTE: Impeller diameter is specific to each model and is noted above by "XXX" in the effected part number.
The "XXX" changes to the exact millimeter trim when ordered.

WARRANTY

Each and every product manufactured by Wilden Pump and Engineering, LLC is built to meet the highest standards of quality. Every pump is functionally tested to insure integrity of operation.

Wilden Pump and Engineering, LLC warrants that pumps, accessories and parts manufactured or supplied by it to be free from defects in material and workmanship for a period of five (5) years from date of installation or six (6) years from date of manufacture, whichever comes first. Failure due to normal wear, misapplication, or abuse is, of course, excluded from this warranty.

Since the use of Wilden pumps and parts is beyond our control, we cannot guarantee the suitability of any pump or part for a particular application and Wilden Pump and Engineering, LLC shall not be liable for any consequential damage or expense arising from the use or misuse of its products on any application. Responsibility is limited solely to replacement or repair of defective Wilden pumps and parts.

All decisions as to the cause of failure are the sole determination of Wilden Pump and Engineering, LLC.

Prior approval must be obtained from Wilden for return of any items for warranty consideration and must be accompanied by the appropriate MSDS for the product(s) involved. A Return Goods Tag, obtained from an authorized Wilden distributor, must be included with the items which must be shipped freight prepaid.

The foregoing warranty is exclusive and in lieu of all other warranties expressed or implied (whether written or oral) including all implied warranties of merchantability and fitness for any particular purpose. No distributor or other person is authorized to assume any liability or obligation for Wilden Pump and Engineering, LLC other than expressly provided herein.

PLEASE PRINT OR TYPE AND FAX TO WILDEN

PUMP INFORMATION			
Item # _____		Serial # _____	
Company Where Purchased _____			
YOUR INFORMATION			
Company Name _____			
Industry _____			
Name _____		Title _____	
Street Address _____			
City _____		State _____	Postal Code _____
Country _____			
Telephone _____		Fax _____	E-mail _____
Web Address _____			
Number of pumps in facility? _____		Number of Wilden pumps? _____	
Types of pumps in facility (check all that apply): <input type="checkbox"/> Diaphragm <input type="checkbox"/> Centrifugal <input type="checkbox"/> Gear <input type="checkbox"/> Submersible <input type="checkbox"/> Lobe			
<input type="checkbox"/> Other _____			
Media being pumped? _____			
How did you hear of Wilden Pump? <input type="checkbox"/> Trade Journal <input type="checkbox"/> Trade Show <input type="checkbox"/> Internet/E-mail <input type="checkbox"/> Distributor			
<input type="checkbox"/> Other _____			

ONCE COMPLETE, FAX TO (909) 783-3440

NOTE: WARRANTY VOID IF PAGE IS NOT FAXED TO WILDEN

WILDEN PUMP & ENGINEERING, LLC