

T2

Original™ Series **PLASTIC** Pumps

EOM

Engineering
Operation &
Maintenance



Simplify your process

TURBO-FLO™
PROGRESSIVE PUMP TECHNOLOGY

WILDEN®
A **DOVER** COMPANY



WIL10210-E-02
REPLACES EOMT2P 8/02

TABLE OF CONTENTS

SECTION 1 CAUTIONS – READ FIRST!1

SECTION 2 PUMP DESIGNATION SYSTEM2

SECTION 3 HOW IT WORKS3

SECTION 4 DIMENSIONAL DRAWING4

SECTION 5 PERFORMANCE CURVES

 Rubber-Fitted5

 TPE-Fitted5

 PTFE-Fitted6

SECTION 6 SUCTION LIFT CURVES & DATA.....6

SECTION 7 INSTALLATION AND OPERATION

 A. Installation7

 B. Operation & Maintenance.....8

 C. Troubleshooting.....9

SECTION 8 DIRECTIONS FOR DISASSEMBLY/REASSEMBLY

 A. T2 PLASTIC Wetted Path Disassembly – Tools Required 10

 B. Air Valve/Center Section – Disassembly, Cleaning, Inspection 13

 C. Reassembly Hints & Tips..... 14

 D. Gasket Kit Installation 14

SECTION 9 EXPLODED VIEW/PARTS LISTING

 A. Rubber/TPE-Fitted 16

 B. PTFE-Fitted 18

SECTION 10 ELASTOMER OPTIONS.....20



CAUTIONS – READ FIRST!



TEMPERATURE LIMITS*

Polypropylene	0°C to 79°C	32°F to 175°F
Carbon-Filled Acetal		
	-28.9°C to 82.2°C	-20°F to 225°F
PTFE PFA	-28.9°C to 148.9°C	-20°F to 300°F
Neoprene	-17.8°C to 93.3°C	0°F to 200°F
Buna-N	-12.2°C to 82.2°C	10°F to 180°F
EPDM	-51.1°C to 137.8°C	-60°F to 280°F
Viton®	-40°C to 176.7°C	-40°F to 350°F
Wil-Flex™	-40°C to 107.2°C	-40°F to 225°F
Polyurethane	12.2°C to 65.6°C	10°F to 150°F
Saniflex™	-28.9°C to 104.4°C	-20°F to 220°F
PTFE	4.4°C to 148.9°C	40°F to 300°F



CAUTION: When choosing pump materials, be sure to check the temperature limits for all wetted components. Example: Viton® has a maximum limit of 176.7°C (350°F) but polypropylene has a maximum limit of only 79.4°C (175°F).



CAUTION: Maximum temperature limits are based upon mechanical stress only. Certain chemicals will significantly reduce maximum safe operating temperatures. Consult engineering guide for chemical compatibility and temperature limits.



CAUTION: Always wear safety glasses when operating pump. If diaphragm rupture occurs, material being pumped may be forced out air exhaust.



WARNING: Prevention of static sparking — If static sparking occurs, fire or explosion could result. Pump, valves, and containers must be properly grounded when handling flammable fluids and whenever discharge of static electricity is a hazard.



CAUTION: Do not exceed 8.6 bar (125 psig) air supply pressure.



CAUTION: Plastic series pumps are made of virgin plastic and are not UV stabilized. Direct sunlight for prolonged periods can cause deterioration of plastics.



CAUTION: Before any maintenance or repair is attempted, the compressed air line to the pump should be disconnected and all air pressure allowed to bleed from pump. Disconnect all intake, discharge and air lines. Drain the pump by turning it upside down and allowing any fluid to flow into a suitable container.



CAUTION: Blow out air line for 10 to 20 seconds before attaching to pump to make sure all pipe line debris is clear. Use an in-line air filter. A 5µ (micron) air filter is recommended.



NOTE: Tighten clamp bands and retainers prior to installation. Fittings may loosen during transportation.



NOTE: When installing PTFE diaphragms, it is important to tighten outer pistons simultaneously (turning in opposite directions) to ensure tight fit.



NOTE: Before starting disassembly, mark a line from each liquid chamber to its corresponding air chamber. This line will assist in proper alignment during reassembly.



CAUTION: Verify the chemical compatibility of the process and cleaning fluid to the pump's component materials in the Chemical Resistance Guide (see E4).



CAUTION: When removing the end cap using compressed air, the air valve end cap may come out with considerable force. Hand protection such as a padded glove or rag should be used to capture the end cap.



CAUTION: Only explosion proof (NEMA 7) solenoid valves should be used in areas where explosion proof equipment is required.



NOTE: Non lube-free pumps must be lubricated. Wilden suggests an arctic 5 weight oil (ISO grade 15). Do not over-lubricate air supply. Over-lubrication will reduce pump performance.



CAUTION: T2 PTFE-fitted pumps come standard from the factory with expanded PTFE gaskets. (See Gasket Kit Installation in Section 8D.)



WILDEN PUMP DESIGNATION SYSTEM

**T2 ORIGINAL™
 PLASTIC**

**25 mm (1") Pump
 Maximum Flow Rate:
 114 LPM (30 GPM)**

LEGEND

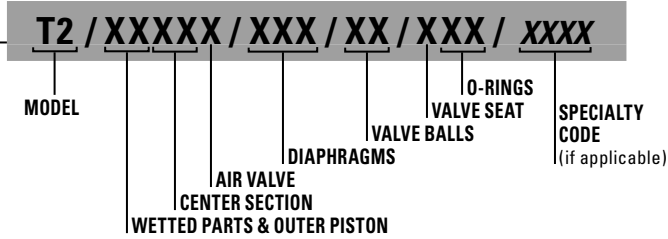

MATERIAL CODES

WETTED PARTS & OUTER PISTON

PP = POLYPROPYLENE /
 POLYPROPYLENE

CENTER SECTION

PP = POLYPROPYLENE

AIR VALVE

B = BRASS
 C = PFA COATED
 N = NICKEL PLATED

DIAPHRAGMS

BNS = BUNA-N (Red Dot)
 EPS = EPDM (Blue Dot)
 FSS = SANIFLEX™
 [Hytrel® (Cream)]
 NES = NEOPRENE (Green Dot)
 PUS = POLYURETHANE (Clear)
 TEU = PTFE W/EPDM
 BACK-UP (White)
 TNU = PTFE W/NEOPRENE
 BACK-UP (White)
 VTS = VITON® (White Dot)
 WFS = WIL-FLEX™ [Santoprene®
 (Orange Dot)]

VALVE BALL

BN = BUNA-N (Red Dot)
 EP = EPDM (Blue Dot)
 FS = SANIFLEX™
 [Hytrel® (Cream)]
 NE = NEOPRENE (Green Dot)
 PU = POLYURETHANE (Brown)
 TF = PTFE (White)
 VT = VITON® (White Dot)
 WF = WIL-FLEX™ [Santoprene®
 (Orange Dot)]

VALVE SEAT

K = PVDF
 P = POLYPROPYLENE

VALVE SEAT O-RING

BN = BUNA-N
 PU = POLYURETHANE (Brown)
 TV = PTFE ENCAP VITON®
 WF = WIL-FLEX™ [Santoprene®]

SPECIALTY CODES

- 0100 Wil-Gard II™ 110V
- 0102 Wil-Gard II™ sensor wires ONLY
- 0103 Wil-Gard II™ 220V
- 0206 PFA coated hardware,
 Wil-Gard II™ sensor wires ONLY
- 0300 Without air valve
- 0400 T2R plastic
- 0402 T2R plastic, PFA coated hardware
- 0404 T2R plastic, DIN flange
- 0406 T2R plastic, PFA coated hardware, DIN flange
- 0415 T2R plastic, Wil-Gard II™ sensor wires ONLY

- 0416 T2R, PFA coated hardware,
 Wil-Gard II™ sensor wires ONLY
- 0420 T2R plastic, Wil-Gard II™ 110V
- 0423 T2R plastic, PFA coated hardware,
 Wil-Gard II™ 110V
- 0424 T2R plastic, Wil-Gard II™ 220V, DIN flange
- 0426 T2R plastic, PFA coated hardware,
 Wil-Gard II™ 220V, DIN flange
- 0428 T2R plastic, Wil-Gard II™ 220V
- 0430 T2R plastic, SS outer pistons
- 0502 PFA coated hardware

- 0560 Split manifold
- 0561 Split manifold, PFA coated hardware
- 0563 Split manifold, discharge ONLY
- 0564 Split manifold, Inlet ONLY
- 0603 PFA coated hardware, Wil-Gard II™ 110V
- 0608 PFA coated hardware, Wil-Gard II™ 220V
- 0660 Split manifold, Wil-Gard II™ 110V
- 0661 Split manifold, PFA coated hardware,
 Wil-Gard II™ 110V

NOTE: MOST ELASTOMERIC MATERIALS USE COLORED DOTS FOR IDENTIFICATION.
 Viton® is registered trademarks of DuPont Dow Elastomers.

THE WILDEN PUMP – HOW IT WORKS

The Wilden diaphragm pump is an air-operated, positive displacement, self-priming pump. These drawings show the flow pattern through the pump upon its initial stroke. It is assumed the pump has no fluid in it prior to its initial stroke.

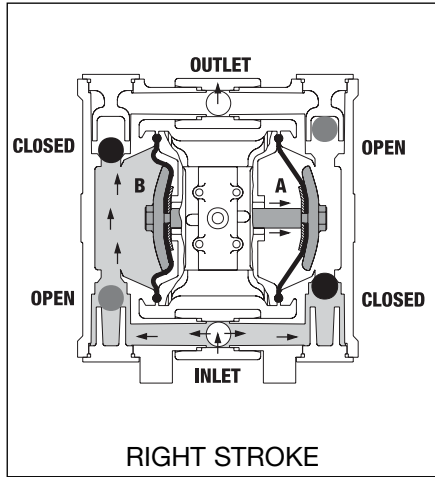

FIGURE 1 The air valve directs pressurized air to the back side of diaphragm A. The compressed air is applied directly to the liquid column separated by elastomeric diaphragms. The diaphragm acts as a separation membrane between the compressed air and liquid, balancing the load and removing mechanical stress from the diaphragm. The compressed air moves the diaphragm away from the center block of the pump. The opposite diaphragm is pulled in by the shaft connected to the pressurized diaphragm. Diaphragm B is on its suction stroke; air behind the diaphragm has been forced out to the atmosphere through the exhaust port of the pump. The movement of diaphragm B toward the center block of the pump creates a vacuum within chamber B. Atmospheric pressure forces fluid into the inlet manifold forcing the inlet valve ball off its seat. Liquid is free to move past the inlet valve ball and fill the liquid chamber (see shaded area).

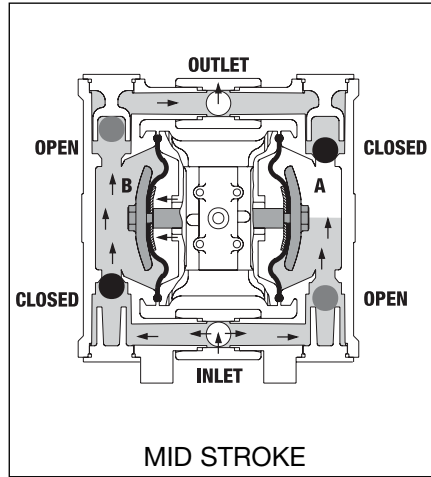

FIGURE 2 When the pressurized diaphragm, diaphragm A, reaches the limit of its discharge stroke, the air valve redirects pressurized air to the back side of diaphragm B. The pressurized air forces diaphragm B away from the center block while pulling diaphragm A to the center block. Diaphragm B is now on its discharge stroke. Diaphragm B forces the inlet valve ball onto its seat due to the hydraulic forces developed in the liquid chamber and manifold of the pump. These same hydraulic forces lift the discharge valve ball off its seat, while the opposite discharge valve ball is forced onto its seat, forcing fluid to flow through the pump discharge. The movement of diaphragm A toward the center block of the pump creates a vacuum within liquid chamber A. Atmospheric pressure forces fluid into the inlet manifold of the pump. The inlet valve ball is forced off its seat allowing the fluid being pumped to fill the liquid chamber.

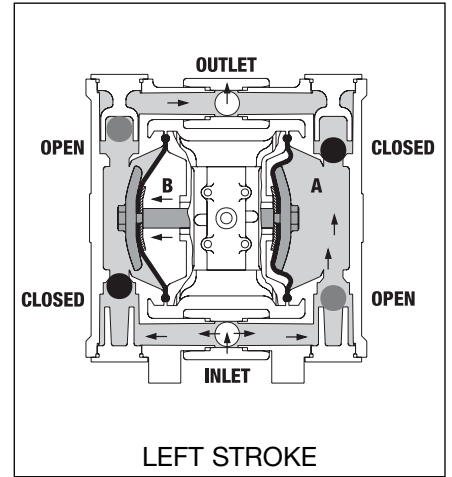
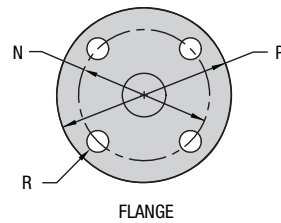
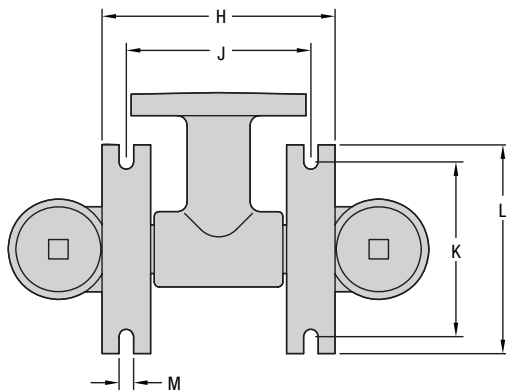
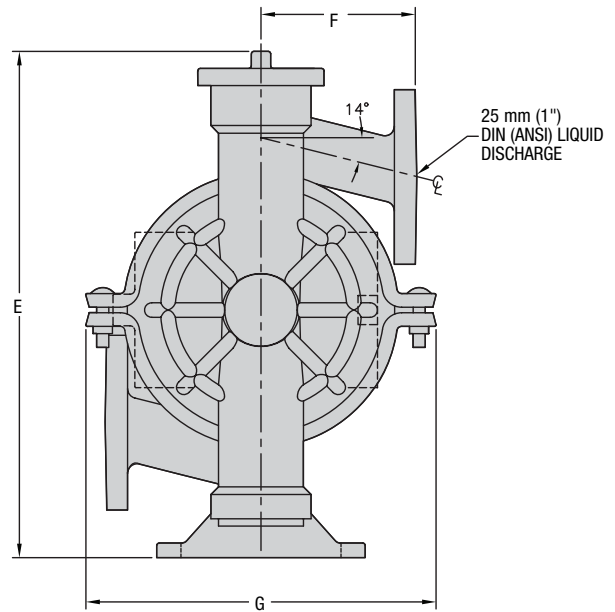
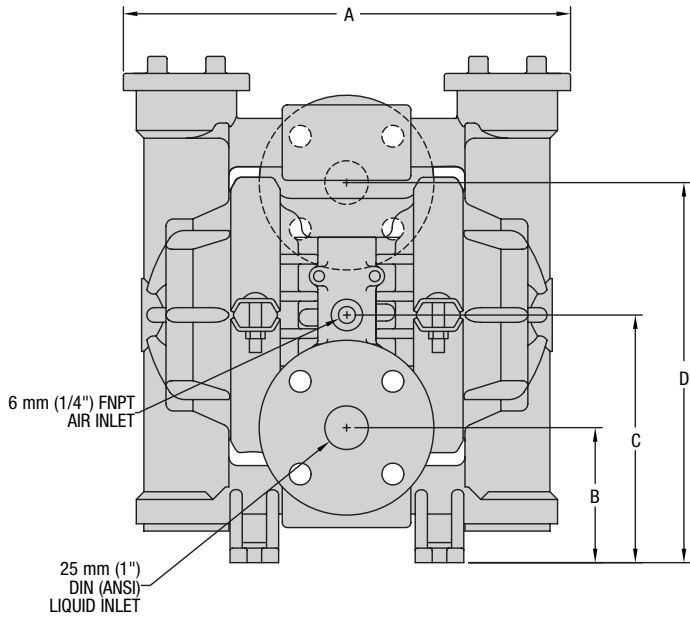

FIGURE 3 At completion of the stroke, the air valve again redirects air to the back side of diaphragm A, which starts diaphragm B on its exhaust stroke. As the pump reaches its original starting point, each diaphragm has gone through one exhaust and one discharge stroke. This constitutes one complete pumping cycle. The pump may take several cycles to completely prime depending on the conditions of the application.

DIMENSIONAL DRAWING

T2R Plastic



DIMENSIONS

ITEM	METRIC (mm)	STANDARD (inch)
A	297	11.7
B	74	2.9
C	163	6.4
D	251	9.9
E	335	13.2
F	107	4.2
G	239	9.4
H	157	6.2
J	124	4.9
K	114	4.5
L	137	5.4
M	10	0.4
	DIN	ANSI
N	85 DIA.	3.1 DIA.
P	115 DIA.	4.3 DIA.
R	14 DIA.	0.6 DIA.



PERFORMANCE

T2R PLASTIC RUBBER-FITTED

Height..... 335 mm (13.2")
 Width..... 297 mm (11.7")
 Depth 239 mm (9.4")
 Est. Ship Weight..... Polypropylene 8.26 kg (18 lbs)
 Air Inlet..... 6 mm (1/4")
 Inlet..... 25 mm (1")
 Outlet 25 mm (1")
 Suction Lift..... 5.5 m Dry (18')
 9.5 m Wet (31')

Displacement per
 Stroke 0.38 l (0.100 gal.)¹
 Max. Flow Rate..... 114 lpm (30 gpm)
 Max. Size Solids 3.2 mm (1/8")

¹Displacement per stroke was calculated at 4.8 bar (70 psig) air inlet pressure against a 2 bar (30 psig) head pressure.

Example: To pump 68.1 lpm (18 gpm) against a discharge pressure head of 2.7 bar (40 psig) requires 4.1 bar (60 psig) and 20.4 Nm³/h (12 scfm) air consumption. (See dot on chart.)

Caution: Do not exceed 8.6 bar (125 psig) air supply pressure.

T2R PLASTIC TPE-FITTED

Height..... 335 mm (13.2")
 Width..... 297 mm (11.7")
 Depth 239 mm (9.4")
 Est. Ship Weight..... Polypropylene 8.26 kg (18 lbs)
 Air Inlet..... 6 mm (1/4")
 Inlet..... 25 mm (1")
 Outlet 25 mm (1")
 Suction Lift..... 3.1 m Dry (10')
 9.5 m Wet (31')

Displacement per
 Stroke 0.39 l (0.104 gal.)¹
 Max. Flow Rate..... 114 lpm (30 gpm)
 Max. Size Solids 3.2 mm (1/8")

¹Displacement per stroke was calculated at 4.8 bar (70 psig) air inlet pressure against a 2 bar (30 psig) head pressure.

Example: To pump 64.4 lpm (17 gpm) against a discharge pressure head of 2.7 bar (40 psig) requires 4.1 bar (60 psig) and 20.4 Nm³/h (12 scfm) air consumption. (See dot on chart.)

Caution: Do not exceed 8.6 bar (125 psig) air supply pressure.

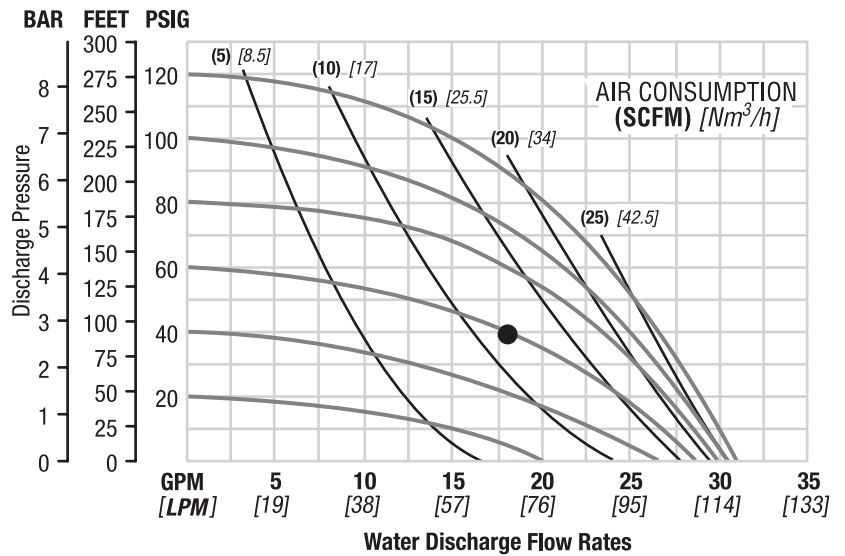

Flow rates indicated on chart were determined by pumping water.

For optimum life and performance, pumps should be specified so that daily operation parameters will fall in the center of the pump performance curve.

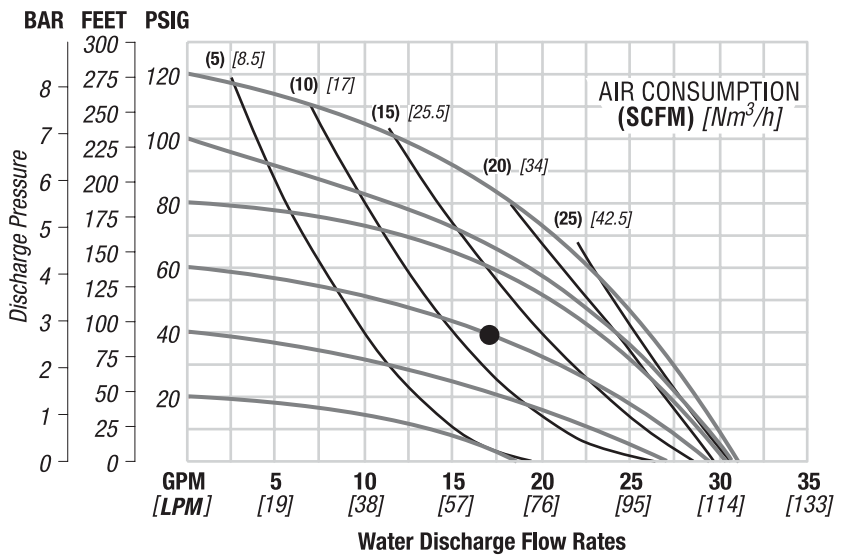

Flow rates indicated on chart were determined by pumping water.

For optimum life and performance, pumps should be specified so that daily operation parameters will fall in the center of the pump performance curve.

PERFORMANCE

**T2R PLASTIC
PTFE-FITTED**

Height..... 335 mm (13.2")
 Width..... 297 mm (11.7")
 Depth 239 mm (9.4")
 Est. Ship Weight..... Polypropylene 8.26 kg (18 lbs)
 Air Inlet..... 6 mm (1/4")
 Inlet..... 25 mm (1")
 Outlet 25 mm (1")
 Suction Lift..... 1.8 m Dry (6')
 9.5 m Wet (31')

Displacement per
 Stroke 0.21 l (0.055 gal.)¹
 Max. Flow Rate..... 102 lpm (27 gpm)
 Max. Size Solids 3.2 mm (1/8")

¹Displacement per stroke was calculated at 4.8 bar (70 psig) air inlet pressure against a 2 bar (30 psig) head pressure.

Example: To pump 49.2 lpm (13 gpm) against a discharge pressure head of 2.7 bar (40 psig) requires 4.1 bar (60 psig) and 25.5 Nm³/h (15 scfm) air consumption. (See dot on chart.)

Caution: Do not exceed 8.6 bar (125 psig) air supply pressure.

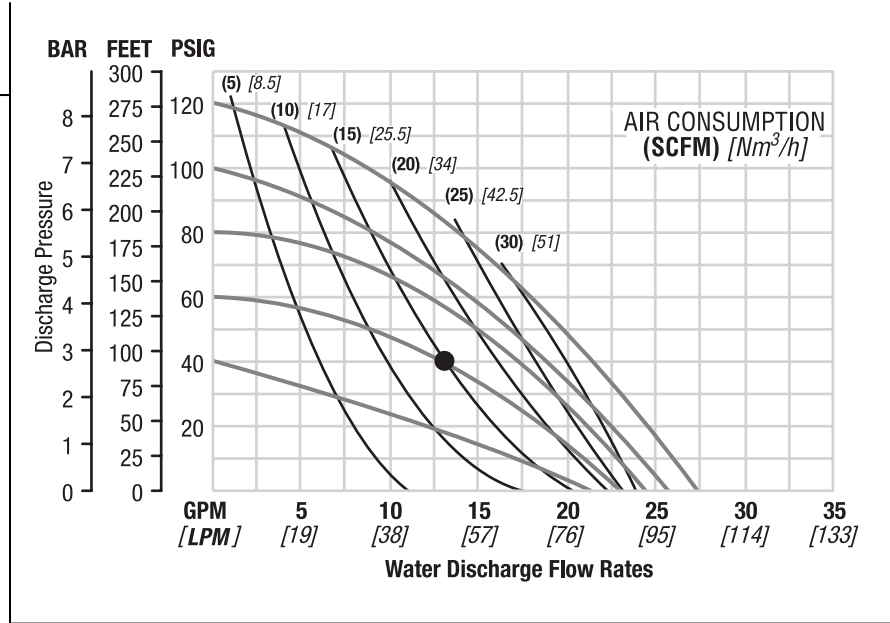

Flow rates indicated on chart were determined by pumping water.

For optimum life and performance, pumps should be specified so that daily operation parameters will fall in the center of the pump performance curve.

Section 6

SUCTION LIFT CURVES & DATA

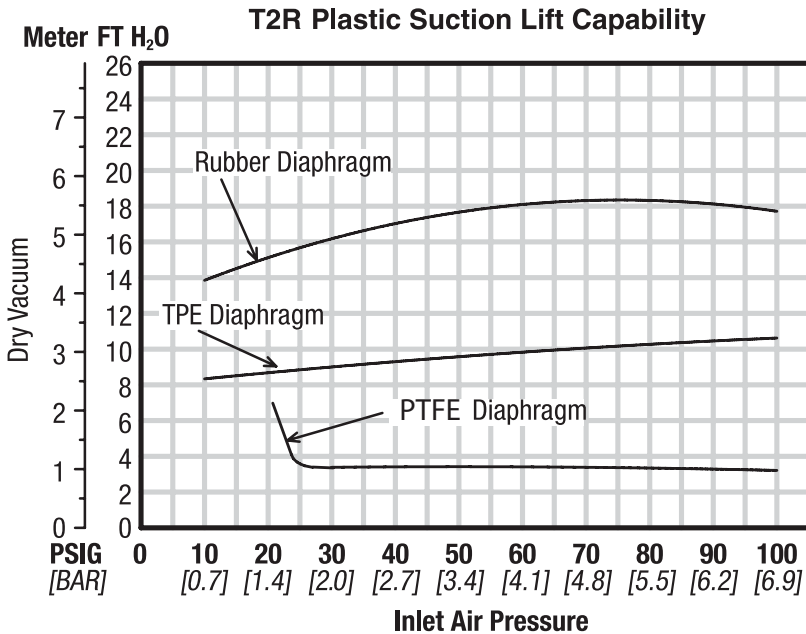

Suction lift curves are calibrated for pumps operating at 1,000' (305 m) above sea level. This chart is meant to be a guide only. There are many variables which can affect your pump's operating characteristics. The number of intake

and discharge elbows, viscosity of pumping fluid, elevation (atmospheric pressure) and pipe friction loss all affect the amount of suction lift your pump will attain.

The Model T2R Plastic pump has a 25 mm (1") inlet and 1" (25 mm) outlet and is designed for flows to 114 lpm (30 gpm). The T2R Plastic pump is manufactured with wetted parts of polypropylene. The center section of the T2R Plastic pump is of polypropylene construction. The air distribution system consists of a brass air valve body, aluminum air valve piston, Glyd™ rings and a bronze center section bushing. A variety of diaphragms, valve balls, valve seats, and rings are available to satisfy temperature, chemical compatibility, abrasion and flex concerns.

The suction pipe size should be at least 25 mm (1") diameter or larger if highly viscous material is being pumped. The suction hose must be non-collapsible, reinforced type as the T2 is capable of pulling a high vacuum. Discharge piping should be at least 25 mm (1"); larger diameter can be used to reduce friction losses. It is critical that all fittings and connections are airtight or a reduction or loss of pump suction capability will result.

For T2R Plastic models, Wilden offers 150 lbs. standard or metric flanges. The following details should be noted when mating these to pipe works:

- A 60–80 shore gasket that covers the entire flange face should be used.
- The gasket should be between .075" and .175" thickness.
- Mating flanges with flat as opposed to raised surfaces should be used for proper mechanical sealing.
- The flanges should be tightened to a minimum of 6.8 N-m (5 ft-lbs) but no more than 13.5 N-m (10 ft-lbs).

INSTALLATION: Months of careful planning, study, and selection efforts can result in unsatisfactory pump performance if installation details are left to chance.

Premature failure and long term dissatisfaction can be avoided if reasonable care is exercised throughout the installation process.

LOCATION: Noise, safety, and other logistical factors usually dictate that "utility" equipment be situated away from the production floor. Multiple installations with conflicting requirements can result in congestion of utility areas, leaving few choices for siting of additional pumps.

Within the framework of these and other existing conditions, every pump should be located in such a way that four key factors are balanced against each other to maximum advantage.

1. **ACCESS:** First of all, the location should be accessible. If it's easy to reach the pump, maintenance personnel will have an easier time carrying out routine inspections and adjustments. Should major repairs become necessary, ease of access can play a key role in speeding the repair process and reducing total downtime.

2. **AIR SUPPLY:** Every pump location should have an air line large enough to supply the volume of air necessary to achieve the desired pumping rate (see pump performance chart). Use air pressure up to a maximum of 8.6 bar (125 psig) (3.4 bar [50 psig] on UL models) depending upon pumping requirements. The use of an air filter before the pump will ensure that the majority of any pipeline contaminants will be eliminated. For best results, the pumps should use an air filter, regulator, and lubricator system.

3. **ELEVATION:** Selecting a site that is well within the pump's suction lift capability will assure that loss-of-prime troubles

will be eliminated. In addition, pump efficiency can be adversely affected if proper attention is not given to elevation (see pump performance chart).

4. **PIPING:** Final determination of the pump site should not be made until the piping problems of each possible location have been evaluated. The impact of current and future installations should be considered ahead of time to make sure that inadvertent restrictions are not created for any remaining sites.

The best choice possible will be a site involving the shortest and the straightest hook-up of suction and discharge piping. Unnecessary elbows, bends, and fittings should be avoided. Pipe sizes should be selected so as to keep friction losses within practical limits. All piping should be supported independently of the pump. In addition, it should line up without placing stress on the pump fittings.

Expansion joints can be installed to aid in absorbing the forces created by the natural reciprocating action of the pump. If the pump is to be bolted down to a solid foundation, a mounting pad placed between the pump and foundation will assist in minimizing pump vibration. Flexible connections between the pump and rigid piping will also assist in minimizing pump vibration. If quick-closing valves are installed at any point in the discharge system, or if pulsation within a system becomes a problem, a surge suppressor should be installed to protect the pump, piping and gauges from surges and water hammer.

When pumps are installed in applications involving flooded suction or suction head pressures, a gate valve should be installed in the suction line to permit closing of the line for pump service.

The T2R can be used in submersible applications only when both wetted and non-wetted portions are compatible with the material being pumped. If the pump is to be used in a submersible application, a hose should be attached to the pump's air exhaust and the exhaust air piped above the liquid level.

If the pump is to be used in a self-priming application, be sure that all connections are airtight and that the suction lift is within the pump's ability. Note: Materials of construction and elastomer material have an effect on suction lift parameters. Please refer to pump performance data.

Pumps in service with a positive suction head are most efficient when inlet pressure is limited to 0.5–0.7 bar (7–10 psig). Premature diaphragm failure may occur if positive suction is 0.8 bar (11 psig) and higher.

THE MODEL T2R WILL PASS 3.2 mm (1/8") SOLIDS. WHENEVER THE POSSIBILITY EXISTS THAT LARGER SOLID OBJECTS MAY BE SUCKED INTO THE PUMP, A STRAINER SHOULD BE USED ON THE SUCTION LINE.

CAUTION: DO NOT EXCEED 8.6 BAR (125 PSIG) AIR SUPPLY PRESSURE.

BLOW OUT AIR LINE FOR 10 TO 20 SECONDS BEFORE ATTACHING TO PUMP TO MAKE SURE ALL PIPE LINE DEBRIS IS CLEAR. ALWAYS USE AN IN-LINE AIR FILTER.

PUMPS SHOULD BE THOROUGHLY FLUSHED WITH WATER BEFORE INSTALLING INTO PROCESS LINES. FDA AND USDA PUMPS SHOULD BE CLEANED AND/OR

SUGGESTED INSTALLATION

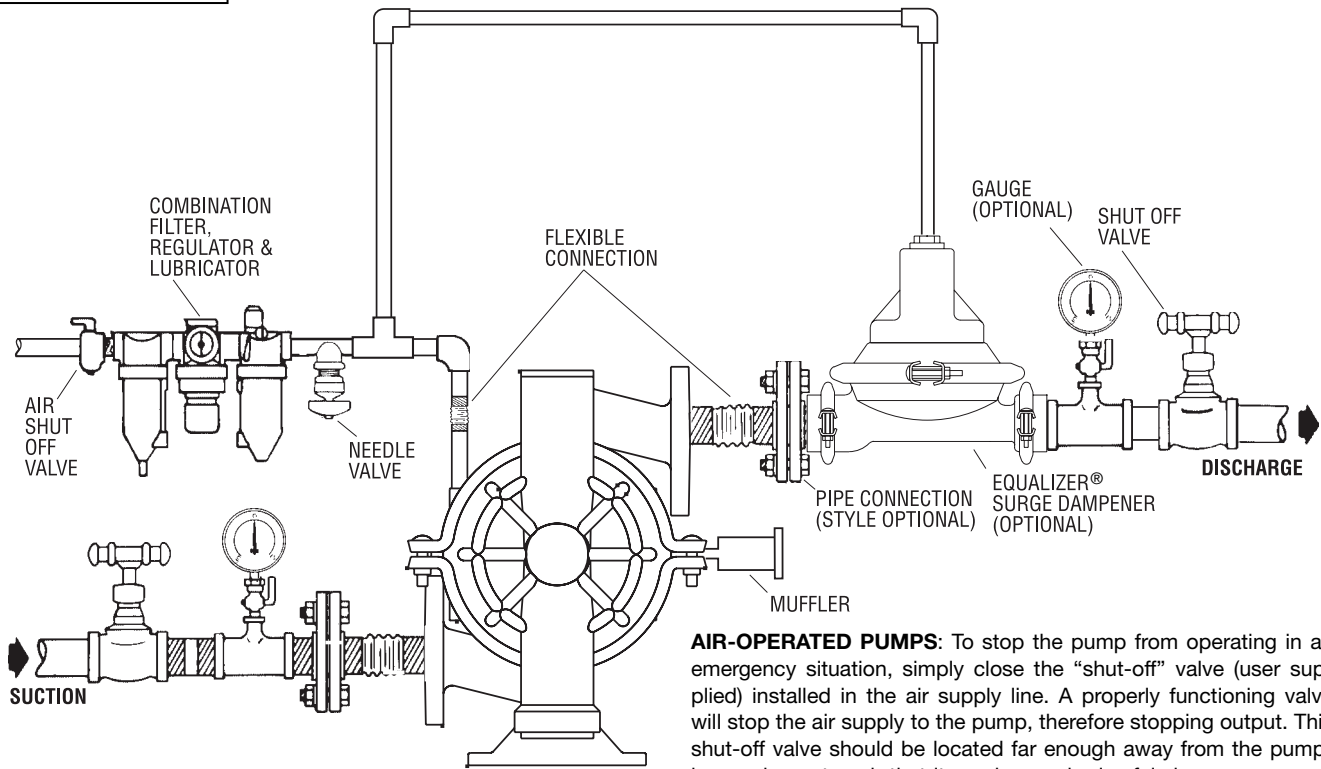

AIR-OPERATED PUMPS: To stop the pump from operating in an emergency situation, simply close the “shut-off” valve (user supplied) installed in the air supply line. A properly functioning valve will stop the air supply to the pump, therefore stopping output. This shut-off valve should be located far enough away from the pumping equipment such that it can be reached safely in an emergency situation.

NOTE: In the event of a power failure, the shutoff valve should be closed, if the restarting of the pump is not desirable once power is regained.

Section 7B

SUGGESTED OPERATION AND MAINTENANCE INSTRUCTIONS

OPERATION: Pump discharge rate can be controlled by limiting the volume and/or pressure of the air supply to the pump (preferred method). An air regulator is used to regulate air pressure. A needle valve is used to regulate volume. Pump discharge rate can also be controlled by throttling the pump discharge by partially closing a valve in the discharge line of the pump. This action increases friction loss which reduces flow rate. This is useful when the need exists to control the pump from a remote location. When the pump discharge pressure equals or exceeds the air supply pressure, the pump will stop; no bypass or pressure relief valve is needed, and pump damage will not occur. The pump has reached a “deadhead” situation and can be restarted by reducing the fluid discharge pressure or increasing the air inlet pressure. The Wilden T2R pump runs solely on compressed air and does not generate heat, therefore your process fluid temperature will not be affected.

RECORDS: When service is required, a record should be made of all necessary repairs and replacements. Over a period of time, such records can become a valuable tool for predicting and preventing future maintenance problems and unscheduled downtime. In addition, accurate records make it possible to identify pumps that are poorly suited to their applications.

MAINTENANCE AND INSPECTIONS: Since each application is unique, maintenance schedules may be different for every pump. Frequency of use, line pressure, viscosity and abrasiveness of process fluid all affect the parts life of a Wilden pump. Periodic inspections have been found to offer the best means for preventing unscheduled pump downtime. Personnel familiar with the pump’s construction and service should be informed of any abnormalities that are detected during operation.

Pump will not run or runs slowly.

1. Check air inlet screen and air filter for debris.
2. Check for sticking air valve, flush air valve in solvent.
3. Check for worn out air valve. If piston face in air valve is shiny instead of dull, air valve is probably worn beyond working tolerances and must be replaced.
4. Check center block Glyd™ rings. If worn excessively, they will not seal and air will simply flow through pump and out air exhaust. Use only Wilden Glyd™ rings as they are of special construction.
5. Check for rotating piston in air valve.
6. Check type of lubricant being used. A higher viscosity oil than suggested may cause the piston to stick or run erratically. Wilden suggests the use of an oil with arctic characteristics (ISO 15-5 wt.).

Pump runs but little or no product flows.

1. Check for pump cavitation; slow pump speed down to match thickness of material being pumped.
2. Check for sticking ball check valves. If material being pumped is not compatible with pump elastomers, swelling may occur. Replace ball check valves and o-rings with the proper elastomers.

3. Check to make sure all suction connections are air tight, especially clamp bands around intake balls.

Pump air valve freezes.

1. Check for excessive moisture in compressed air. Either install dryer or hot air generator for compressed air.

Air bubbles in pump discharge.

1. Check for ruptured diaphragm.
2. Check tightness of clamp bands, especially at intake manifold.

Product comes out air exhaust.

1. Check for diaphragm rupture.
2. Check tightness of piston plates to shaft.

Pump rattles.

1. Create false discharge head or suction lift.

DIRECTIONS FOR DISASSEMBLY/REASSEMBLY

Tools Required:

- 1/2" Box Wrench
- 1/2" Socket
- 1/2" Socket Drive
- 2-1" Sockets or Adjustable Wrench
- Adjustable Wrench
- Vise equipped with soft jaws (such as plywood, plastic or other suitable material)

CAUTION: Before any maintenance or repair is attempted, the compressed air line to the pump should be disconnected and all air pressure allowed to bleed from the pump. Disconnect all intake, discharge, and air lines. Drain the pump by turning it upside down and allowing any fluid to flow into a suitable container. Be aware of any hazardous effects of contact with your process fluid. The Wilden model T2 has a 25 mm (1") inlet and 25 mm (1") outlet and is designed for flows up to 114 lpm (30 gpm). The wetted path comes in polypropylene. The single-piece center section, consisting of center block and air chambers, is molded of polypropylene or aluminum. The air valve body is manufactured of brass or high-tech engineered thermoplastics. All o-rings used in the pump are of a special material and shore hardness that should only be replaced with factory-supplied parts.

NOTE: The model used for these instructions incorporates rubber diaphragms, balls, and seats. Models with PTFE diaphragms, balls and seats are the same except where noted.

DISASSEMBLY:



Step 1.

Figure 1

Before starting disassembly, mark a line from each liquid chamber to its corresponding air chamber. This line will assist in proper alignment during reassembly.

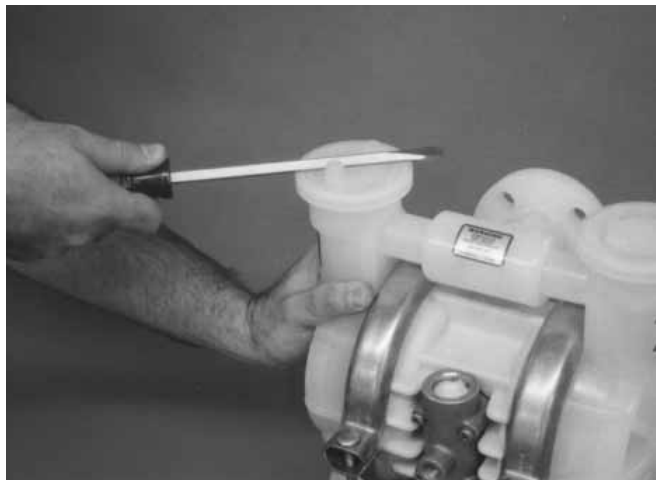

Step 2.

Figure 2

Using a screwdriver or other long, slim object, loosen the top liquid retainers from the liquid chambers.

DIRECTIONS FOR DISASSEMBLY/REASSEMBLY



Step 3. *Figure 3*
Remove the top liquid retainer to expose the valve balls, valve seats and valve seat o-rings.

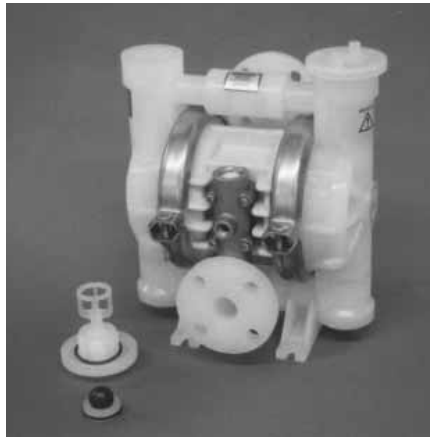

Step 4. *Figure 4*
Remove the top liquid retainer and retainer o-rings, discharge valve balls, seats and valve seat o-rings from the liquid chamber and inspect for nicks, gouges, chemical attack or abrasive wear. Replace worn parts with genuine Wilden parts for reliable performance.

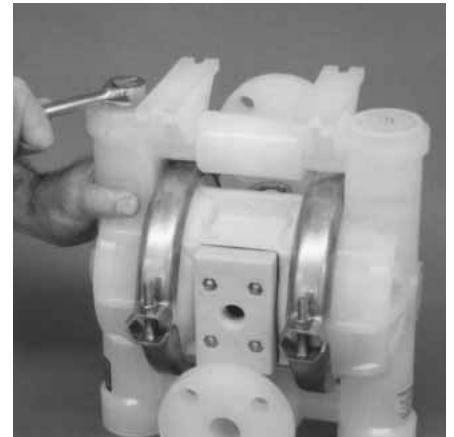

Step 5. *Figure 5*
Using a 1/2" socket driver, loosen the bottom retainers.



Step 6. *Figure 6*
Remove the bottom liquid retainer and retainer o-rings, discharge valve balls, seats and valve seat o-rings from the liquid chamber and inspect for nicks, gouges, chemical attack or abrasive wear. Replace worn parts with genuine Wilden parts for reliable performance.

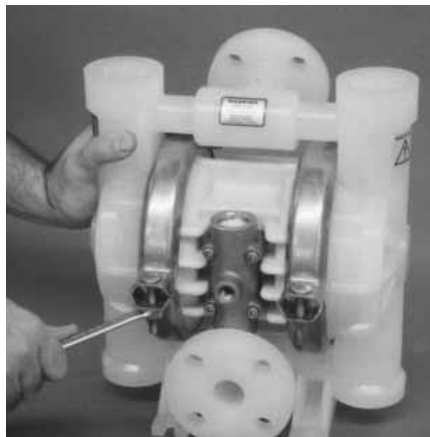

Step 7. *Figure 7*
With a 1/2" box wrench, loosen the large clamp bands that secure the liquid chambers to the center section.

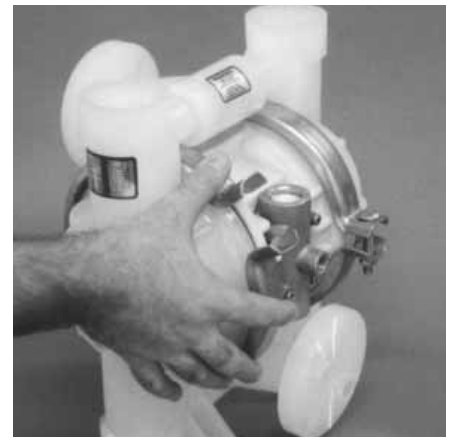

Step 8. *Figure 8*
Rotate the clamp bands so that they can be removed.

DIRECTIONS FOR DISASSEMBLY/REASSEMBLY

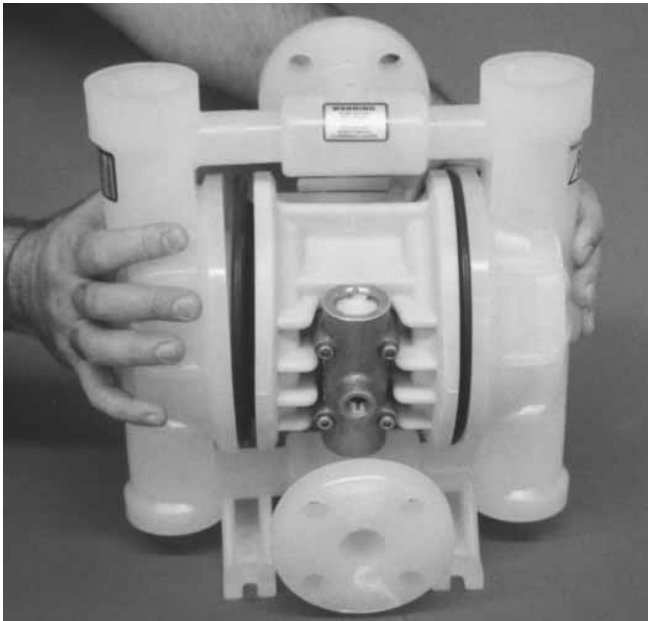

Step 9. *Figure 9*
After clamp bands are removed, pull liquid chambers apart.

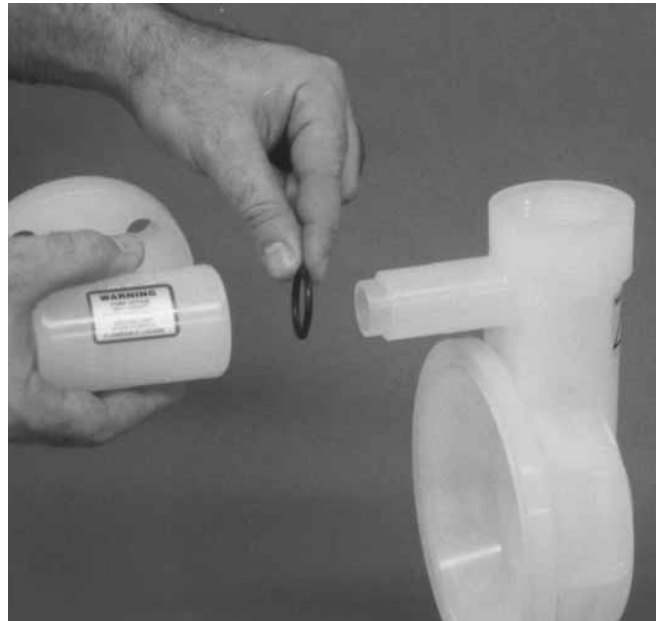

Step 10. *Figure 10*
Remove tee section from liquid chamber and inspect o-rings for signs of wear. Replace worn parts with genuine Wilden parts for reliable performance.



Step 11. *Figure 11*
Using two 1" sockets, remove diaphragm assembly from center section assembly.



Step 12. *Figure 12*
To remove the remaining diaphragm assembly from the shaft, secure shaft with soft jaws (a vise fitted with plywood or other suitable material) to ensure shaft is not nicked, scratched, or gouged. Using an adjustable wrench, remove diaphragm assembly from shaft. Inspect all parts for wear and replace with genuine Wilden parts if necessary.



Step 13. *Figure 13*
Inspect diaphragms, outer and inner pistons and disc spring (not shown) for signs of wear. Replace with genuine Wilden parts if necessary.

The air valve assembly consists of the air valve body and piston. The unique design of the air valve relies only on differential pressure to cause the air valve to shift. It is reliable and simple to maintain. The bushing in the center block, along with the diaphragm shaft, provides the “trigger” to tell the air valve to shift. The following procedure will ensure that the air valve on your Wilden pump will provide long trouble-free service.

AIR VALVE BODY AND PISTON ASSEMBLY AND DISASSEMBLY

The air valve body and piston can be disconnected from the pump by removing the four socket-head cap screws which attach it to the center section. The piston in the air valve is aluminum with a dark anodized coating. The piston should move freely and the ports in the piston should line up with the ports on the face of the air valve body. The piston should also appear to be dull black in color. If the piston appears to be a shiny aluminum color, the air valve is probably worn beyond working tolerances and should be replaced.

If the piston does not move freely in the air valve, the entire air valve should be immersed in a cleaning solution. (NOTE: Do not force the piston by inserting a metal object.) This soaking should remove any accumulation of sludge and grit which is preventing the air valve piston from moving freely. If the air valve piston does not move freely after the above cleaning, the air valve should be disassembled as follows: Remove the snap ring from the top end of the air valve and apply an air jet alternately to the two holes located in the face of the air valve until the end cap is blown out.

[CAUTION: The air valve end cap may come out with considerable force. Hand protection such as a padded glove or a rag should be used to capture the end cap.] Inspect the piston and cylinder bore for nicks and scoring.

Small nicks can usually be dressed out and the piston returned to service. Inspect the cylinder end caps. Make sure that the guide pin is straight and smooth or the piston will not move freely in the cylinder. Clean out anti-centering pin holes located on each side of the piston. Pin holes are located on each side of the annular groove on the top of the piston and travel to each end. New o-rings should be installed on the end caps. Lubricate the o-rings and install the end caps, assuring that proper alignment of the piston and cylinder ports is maintained. Use an oil with arctic characteristics (ISO 15-5wt).

GLYD™ RING REPLACEMENT / CENTER SECTION

The pump’s center section consists of a molded housing with a bronze bushing. (Bushing is not removable.) This bushing has grooves cut into the inside diameter. Glyd™ o-rings are installed in these grooves. When the Glyd™ rings become worn, they will no longer seal and must be replaced. This is most easily accomplished by using a tool called an o-ring pick, available through most industrial supply companies.

There are two versions of center sections: PRE-ENHANCED (pumps manufactured before March 1, 1992) and ENHANCED (pumps manufactured since March 1, 1992). An encircled letter “E” stamped on the top of the center section denotes the ENHANCED type center section (Figure C).

Please contact your local authorized distributor for enhanced air distribution retrofit packages.

If the encircled “E” is present, an enhanced (02-3800-09-07) shaft should be utilized to maximize performance. The center section Glyd™ rings (02-3210-55-225) must be installed in the appropriate grooves as shown (1, 3, 6, 8).

If the encircled “E” is not present, a pre-enhanced shaft (02-3800-09 or 02-3820-09) must be utilized. An enhanced (non-dented) shaft will not function correctly. The center section o-rings (02-3200-52) must be installed in the appropriate grooves as shown (1, 3, 4, 6).

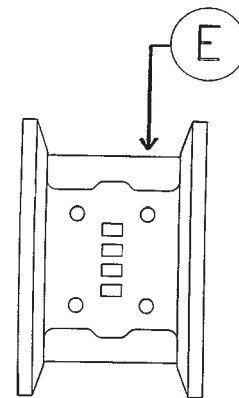
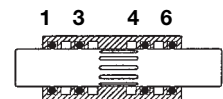

Figure C



PRE-ENHANCED SHAFT



PRE-ENHANCED CONFIGURATION

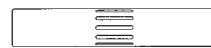

ENHANCED SHAFT

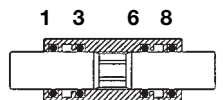

ENHANCED CONFIGURATION

*Refer to Section 8C for the required torque specifications.

REASSEMBLY HINTS & TIPS

ASSEMBLY:

Upon performing applicable maintenance to the air distribution system, the pump can now be reassembled. Please refer to the disassembly instructions for photos and parts placement. To reassemble the pump, follow the disassembly instructions in reverse order. The air distribution system needs to be assembled first, then the diaphragms and finally the wetted path. Please find the applicable torque specifications on this page. The following tips will assist in the assembly process.

- Clean the inside of the center section shaft bushing to ensure no damage is done to new seals.
- Stainless bolts should be lubed to reduce the possibility of seizing during tightening.
- Level the water chamber side of the intake/discharge manifold to ensure a proper sealing surface. This is most easily accomplished by placing them on a flat surface prior to tightening their clamp bands to the desired torque (see this page for torque specs).
- Be sure to tighten outer pistons simultaneously on PTFE-fitted pumps to ensure proper torque values.
- Ensure proper mating of liquid chambers to manifolds prior to tightening vertical bolts. Overhang should be equal on both sides.
- Apply a small amount of Loctite 242 to the steel bore of the shaft from the diaphragm assembly.

MAXIMUM TORQUE SPECIFICATIONS

Description of Part	Plastic Pumps
Air Valve	3.4 N•m (30 in-lbs)
Outer Piston — Rubber- and PTFE-fitted	27.1 N•m (20 ft-lbs)
Top and Bottom Retainers	14.1 N•m (125 in-lbs)
Large Clamp Band — Rubber-fitted	10.7 N•m (95 in-lbs)
Large Clamp Band — PTFE-fitted	14.1 N•m (125 in-lbs)

Section 8D

GASKET KIT INSTALLATION

PTFE-fitted T2R pumps require expanded PTFE material around the diaphragm bead (P/N 02-9500-99). Carefully prepare sealing surfaces by removing all debris and foreign matter from

diaphragm bead and all mating surfaces. If necessary, smooth or deburr all sealing surfaces. Mating surfaces must be properly aligned in order to ensure positive sealing characteristics.

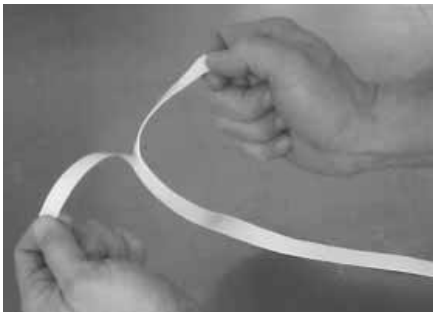

Step 1. *Figure 1*

Gently remove the adhesive covering from the back of the PTFE tape. Ensure that the adhesive strip remains attached to the PTFE tape and is not removed with the adhesive covering.



Step 2. *Figure 2*

Starting at any point, place the PTFE tape directly on top of the diaphragm bead. Press lightly on the tape to ensure that the adhesive holds it in place during assembly. Do not stretch the tape during placement on the diaphragm.



Step 3. *Figure 3*

The ends of the tape should overlap approximately 13 mm (1/2"). Proceed to install the PTFE tape on the remaining diaphragm.

Finding spares a nightmare?

Sleep easier with



PRODUCTS:
AODDP
(Air Operated Double Diaphragm Pumps)

- Warren-Rupp
- ARO
- Other



PUMP PARTS
(Low Cost)

- Diaphragms
- Valve balls
- Valve seats



KNOWLEDGE & SERVICE

- Competitive pricing
- Delivery
- Service
- Inventory

Spectrom is not your typical after market part supplier. We do not simply sell pump parts; we provide value added procurement solutions.

Our unique network enables us to purchase effectively, resulting in low cost solutions. We also know that low purchase price is not enough - quality, integrity and inventory are also important. Spectrom is structured to provide Pre and Post sales support, giving our customers value added application and pump knowledge.

Contact us to have a procurement solution developed for you. We don't just fit you into a generic system, we develop specific solutions that achieve results.

Spectrom will ship your order from our facility within 3 working days!

WARNING These parts may exhibit better life than OEM parts.

1-909-512-1261



www.spectromparts.com

EXPLODED VIEW/PARTS LISTING

T2R PLASTIC

Rubber-Fitted

EXPLODED VIEW

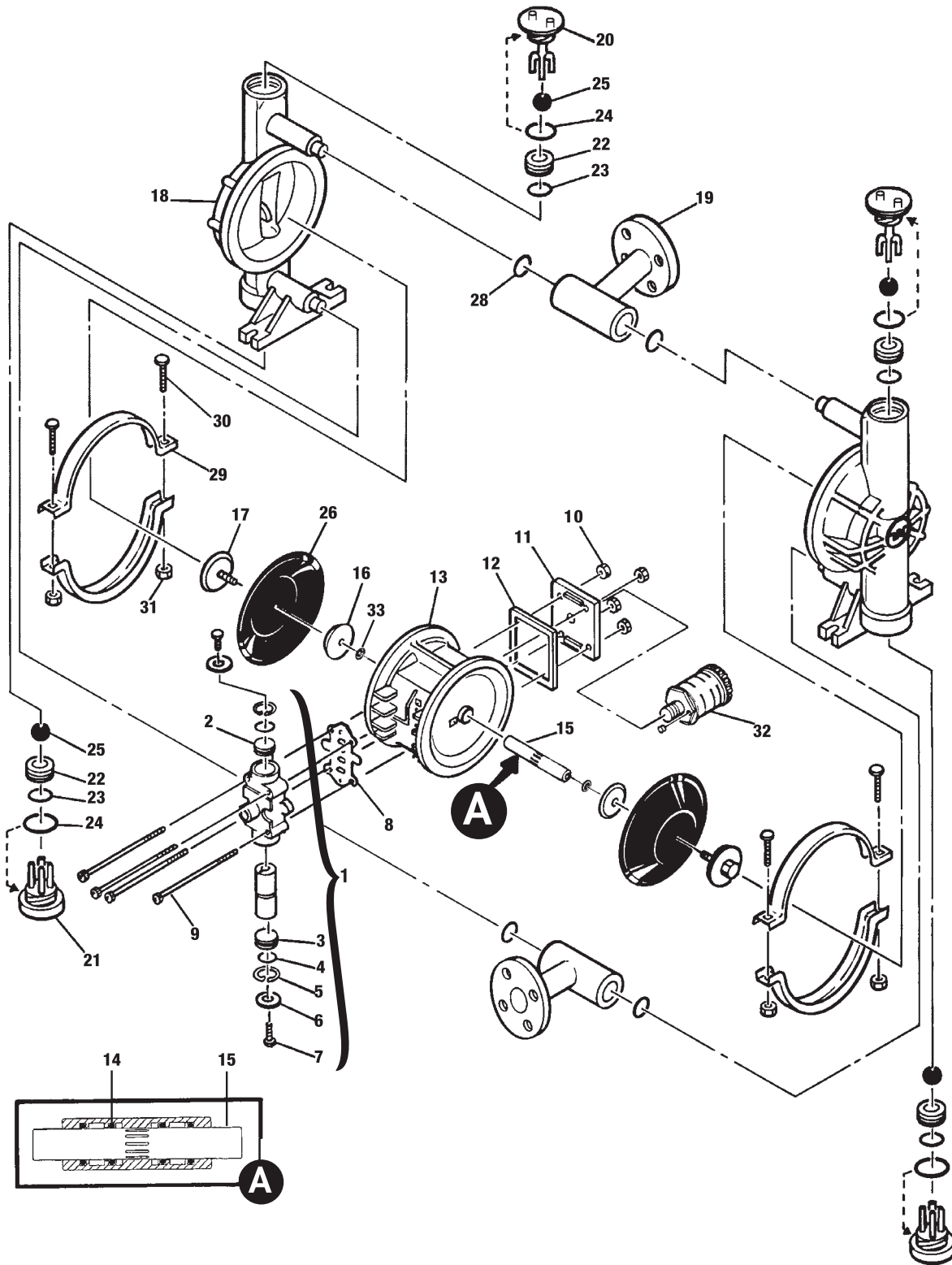

EXPLODED VIEW/PARTS LISTING

T2R PLASTIC

Rubber-Fitted

PARTS LISTING

Item No.	Part Description	Qty. Per Pump	T2/PPPB/400	T2/PPPC/402
			P/N	P/N
1	Air Valve Assembly*	1	02-2000-07	02-2000-05
2	End Cap w/Guide	1	02-2301-23	02-2301-23
3	End Cap w/o Guide	1	02-2331-23	02-2331-23
4	End Cap O-Ring	2	02-3200-52-200	02-3200-52-200
5	Snap Ring	2	02-2650-03	02-2650-03
6	End Cap Cover	2	N/R	02-2420-55
7	End Cap Bolt	2	N/R	02-2450-22
8	Air Valve Gasket — Buna-N	1	02-2600-52	02-2600-52
9	Air Valve Bolt 1/4"-20 x 6"	4	02-6000-03	02-6000-05
10	Air Valve Nut 1/4"-20	4	04-6400-03	04-6400-05
11	Muffler Plate	1	02-3180-20	02-3180-20
12	Muffler Plate Gasket — Buna-N	1	02-3500-52-500	02-3500-52-500
13	Center Section	1	02-3151-20-225	02-3151-20-225
14	Center Section Glyd™ Ring	4	02-3210-55-225	02-3210-55-225
15	Shaft	1	02-3800-03-07	02-3800-03-07
16	Inner Piston	2	02-3700-08	02-3700-08
17	Outer Piston	2	02-4550-21-500	02-4550-21-500
18	Liquid Chamber	2	02-5001-20-400	02-5001-20-400
19	Manifold Tee Section ¹	2	02-5160-20-400	02-5160-20-400
20	Top Retainer	2	02-5411-20-400	02-5411-20-400
21	Bottom Retainer	2	02-5420-20-400	02-5420-20-400
22	Valve Seat	4	02-1120-20-400	02-1120-20-400
23	Valve Seat O-Ring**	4	*	*
24	Retainer O-Ring**	4	*	*
25	Valve Ball**	4	*	*
26	Diaphragm**	2	*	*
27	Back-up Diaphragm	2	N/R	N/R
28	Tee Section O-Ring**	4	*	*
29	Clamp Band Assembly (Incl. 30 & 31)	2	02-7300-03-400	02-7300-05-402
30	Clamp Band Bolt 5/16"-18 x 1-3/4"	4	08-6050-03-500	08-6050-05-500
31	Clamp Band Nut 5/16"-18	4	08-6400-03	08-6400-05
32	Muffler	1	02-3510-99	02-3510-99
33	Disc Spring	2	02-6802-08	02-6802-08

¹DIN Flange: Polypropylene = 02-5160-20-404

*Air Valve Assembly includes items 2-7.

**Refer to corresponding elastomer chart in Section 10 for correct part number.

0400 Specialty Code = T2R Champ

0402 Specialty Code = T2R Champ w/PTFE PFA Coating

All boldface items are primary wear parts.

EXPLODED VIEW/PARTS LISTING

T2R PLASTIC

PTFE-Fitted

EXPLODED VIEW

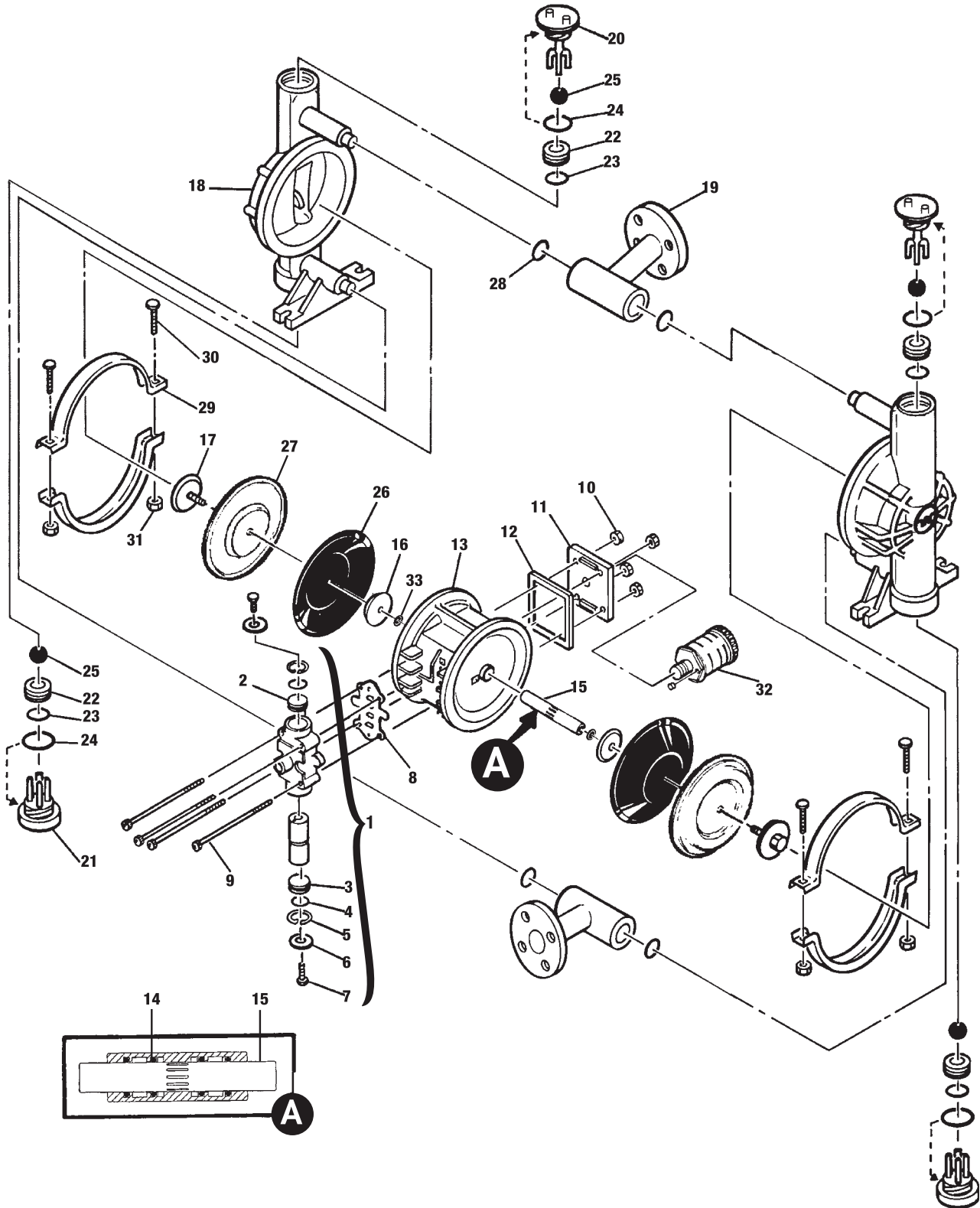

EXPLODED VIEW/PARTS LISTING

T2R PLASTIC

PTFE-Fitted

PARTS LISTING

Item No.	Part Description	Qty. Per Pump	T2/PPPB/400	T2/PPPC/402
			P/N	P/N
1	Air Valve Assembly*	1	02-2000-07	02-2000-05
2	End Cap w/Guide	1	02-2301-23	02-2301-23
3	End Cap w/o Guide	1	02-2331-23	02-2331-23
4	End Cap O-Ring	2	02-3200-52-200	02-3200-52-200
5	Snap Ring	2	02-2650-03	02-2650-03
6	End Cap Cover	2	N/R	02-2420-55
7	End Cap Bolt	2	N/R	02-2450-22
8	Air Valve Gasket — Buna-N	1	02-2600-52	02-2600-52
9	Air Valve Bolt 1/4"-20 x 6"	4	02-6000-03	02-6000-05
10	Air Valve Nut 1/4"-20	4	04-6400-03	04-6400-05
11	Muffler Plate	1	02-3180-20	02-3180-20
12	Muffler Plate Gasket — Buna-N	1	02-3500-52-500	02-3500-52-500
13	Center Section	1	02-3151-20-225	02-3151-20-225
14	Center Section Glyd™ Ring	4	02-3210-55-225	02-3210-55-225
15	Shaft	1	02-3820-03-07	02-3820-03-07
16	Inner Piston	2	02-3750-01	02-3750-01
17	Outer Piston	2	02-4600-21-500	02-4600-21-500
18	Liquid Chamber	2	02-5001-20-400	02-5001-20-400
19	Manifold Tee Section ¹	2	02-5160-20-400	02-5160-20-400
20	Top Retainer	2	02-5411-20-400	02-5411-20-400
21	Bottom Retainer	2	02-5420-20-400	02-5420-20-400
22	Valve Seat	4	02-1120-20-400	02-1120-20-400
23	Valve Seat O-Ring**	4	**	**
24	Retainer O-Ring**	4	**	**
25	Valve Ball**	4	**	**
26	Diaphragm**	2	02-1010-55	02-1010-55
27	Back-up Diaphragm	2	02-1060-51	02-1060-51
28	Tee Section O-Ring**	4	**	**
29	Clamp Band Assembly (Incl. 30 & 31)	2	02-7300-03-400	02-7300-05-402
30	Clamp Band Bolt 5/16"-18 x 1-3/4"	4	08-6050-03-500	08-6050-05-500
31	Clamp Band Nut 5/16"-18	4	08-6400-03	08-6400-05
32	Muffler	1	02-3510-99	02-3510-99
33	Disc Spring	2	02-6802-08	02-6802-08
34	Expanded PTFE Gasket Tape (Not shown)	1	02-9500-99	02-9500-99

¹DIN Flange: Polypropylene = 02-5160-20-404, PVDF = 02-5160-21-404

*Air Valve Assembly includes items 2-7.

**Refer to corresponding elastomer chart in Section 10 for correct part number.

0400 Specialty Code = T2R Champ

0402 Specialty Code = T2R Champ w/PTFE PFA Coating

All boldface items are primary wear parts.

ELASTOMER OPTIONS

T2R PLASTIC

Material	Color Code	Diaphragm P/N (2)	Valve Ball P/N (4)	Valve Seat* O-Ring P/N (4)	Tee Section O-Ring P/N (4)	Top Retainer O-Ring P/N (2)	Bottom Retainer O-Ring P/N (2)
Polyurethane	Natural	02-1010-50	02-1080-50	02-1200-50-400	02-1300-50-400	02-1220-50	02-1230-50
Buna-N	Red	02-1010-52	02-1080-52	08-2390-52	04-2390-52	04-2390-52-700	02-1230-52
PTFE Encapsulated Viton®	None	N/A	N/A	02-1200-60-400	02-1300-60-400	02-1220-60	02-1230-60
Neoprene	Green	02-1010-51	02-1080-51	N/A	N/A	N/A	N/A
Viton®	Silver	02-1010-53	02-1080-53	N/A	N/A	N/A	N/A
EPDM	Blue	02-1010-54	02-1080-54	N/A	N/A	N/A	N/A
PTFE	White	02-1010-55	02-1080-55	N/A	N/A	N/A	N/A
Saniflex™	Off-White	02-1010-56	02-1080-56	N/A	N/A	N/A	N/A
Wil-Flex™	Orange	02-1010-58	02-1080-58	02-1200-58-400	02-1300-58-400	02-1220-58	02-1230-58
Neoprene Backup	Black	02-1060-51 ¹	N/A	N/A	N/A	N/A	N/A

1. Saniflex™ back-up diaphragms, P/N 02-1060-56, are available upon request. Please consult your local distributor.

*NOTE: Rubber valve seats do not require an o-ring.

WARRANTY

Each and every product manufactured by Wilden Pump and Engineering, LLC is built to meet the highest standards of quality. Every pump is functionally tested to insure integrity of operation.

Wilden Pump and Engineering, LLC warrants that pumps, accessories and parts manufactured or supplied by it to be free from defects in material and workmanship for a period of five (5) years from date of installation or six (6) years from date of manufacture, whichever comes first. Failure due to normal wear, misapplication, or abuse is, of course, excluded from this warranty.

Since the use of Wilden pumps and parts is beyond our control, we cannot guarantee the suitability of any pump or part for a particular application and Wilden Pump and Engineering, LLC shall not be liable for any consequential damage or expense arising from the use or misuse of its products on any application. Responsibility is limited solely to replacement or repair of defective Wilden pumps and parts.

All decisions as to the cause of failure are the sole determination of Wilden Pump and Engineering, LLC.

Prior approval must be obtained from Wilden for return of any items for warranty consideration and must be accompanied by the appropriate MSDS for the product(s) involved. A Return Goods Tag, obtained from an authorized Wilden distributor, must be included with the items which must be shipped freight prepaid.

The foregoing warranty is exclusive and in lieu of all other warranties expressed or implied (whether written or oral) including all implied warranties of merchantability and fitness for any particular purpose. No distributor or other person is authorized to assume any liability or obligation for Wilden Pump and Engineering, LLC other than expressly provided herein.

PLEASE PRINT OR TYPE AND FAX TO WILDEN

PUMP INFORMATION			
Item # _____		Serial # _____	
Company Where Purchased _____			
YOUR INFORMATION			
Company Name _____			
Industry _____			
Name _____		Title _____	
Street Address _____			
City _____	State _____	Postal Code _____	Country _____
Telephone _____	Fax _____	E-mail _____	Web Address _____
Number of pumps in facility? _____		Number of Wilden pumps? _____	
Types of pumps in facility (check all that apply): <input type="checkbox"/> Diaphragm <input type="checkbox"/> Centrifugal <input type="checkbox"/> Gear <input type="checkbox"/> Submersible <input type="checkbox"/> Lobe			
<input type="checkbox"/> Other _____			
Media being pumped? _____			
How did you hear of Wilden Pump? <input type="checkbox"/> Trade Journal <input type="checkbox"/> Trade Show <input type="checkbox"/> Internet/E-mail <input type="checkbox"/> Distributor			
<input type="checkbox"/> Other _____			

ONCE COMPLETE, FAX TO (909) 783-3440

NOTE: WARRANTY VOID IF PAGE IS NOT FAXED TO WILDEN

WILDEN PUMP & ENGINEERING, LLC